

Physics 517/617 Homework 2 (Due July 8th)

Problems for AC circuits

1) Calculate the impedance Z_{AB} in the form $a + jb$ and $|Z|e^{j\phi}$ for the following circuits:

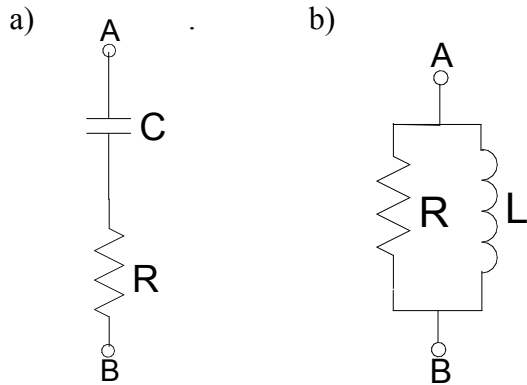

2) Design a high-pass RL filter with a 3 dB point of 100 kHz. Use a $1\text{ k}\Omega$ resistance. Explain in words why the high-pass filter attenuates the low frequencies.

3) For the circuit shown at the right, $L = 50\text{ mH}$, $C = 200\text{ pF}$, and $R = 100\ \Omega$, and $v(t) = V_0 \cos \omega t$ with $V_0 = 10\text{ V}$ and ω is adjustable. Find (a) the resonant frequency of the circuit, f_0 , (b) the Q of the circuit, (c) the amplitude of the voltage across the resistor, the inductor, and the capacitor, V_R , V_L , and V_C , when the circuit is driven at its resonant frequency.

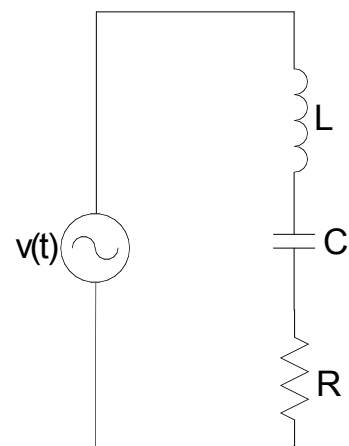

4) For each of the following circuits identify the corresponding magnitude Bode plot. For most cases the Bode plot can be identified by considering the limits $\omega \rightarrow 0$ and $\omega \rightarrow \infty$.

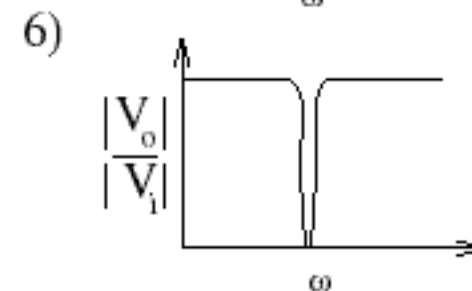
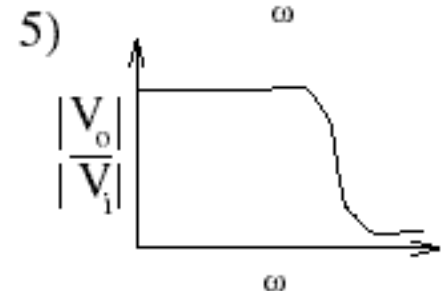
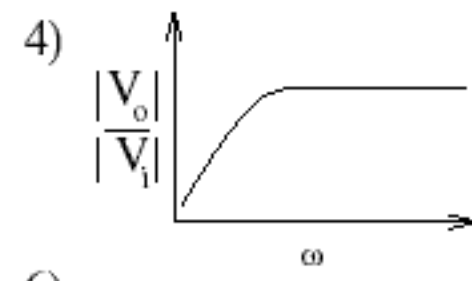
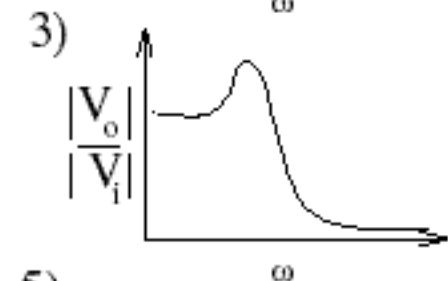
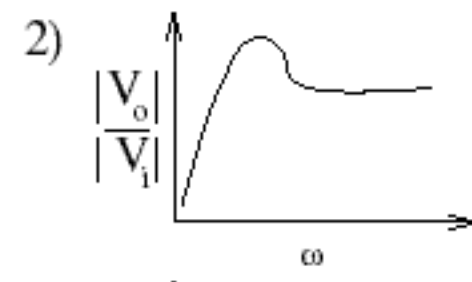
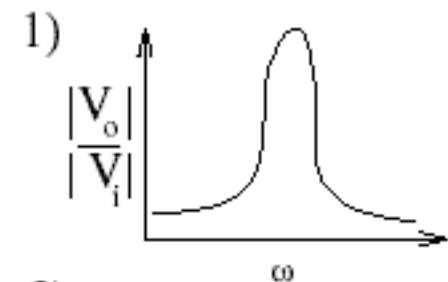
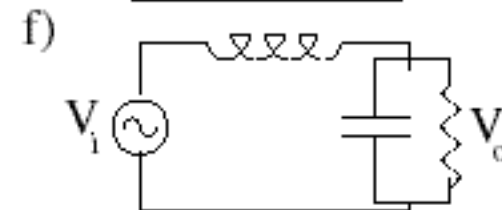
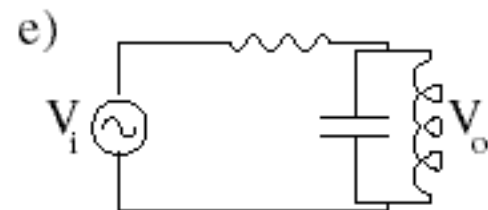
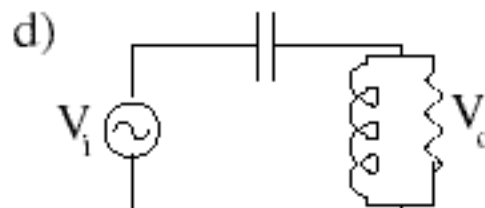
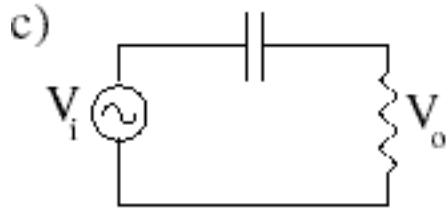
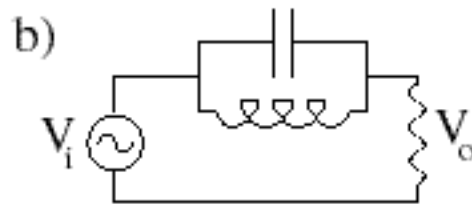
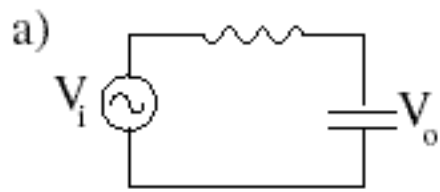

5) Use SPICE to make Bode plots of the magnitude (gain) and phase of the transfer function for the filter shown below for frequencies from 10 Hz to 1 MHz. . Apply your results to the specific case of a 1.5 kHz, 2.0 V amplitude input to the filter , i.e., $v_0(t) = V_0 \cos(\omega t) = 2 \cos(2\pi \cdot 1.5 \cdot 10^3 \cdot t)$. Find (a) the voltage at the output across C_2 and (b) the (numeric) value of the voltage at the output for time, $t = 0.001$ s.

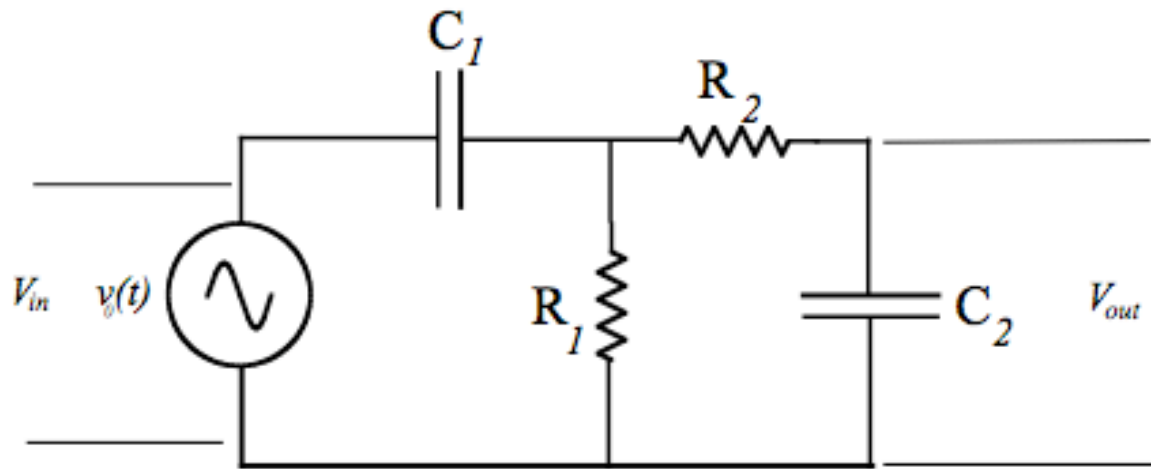

$$C_1 = 0.3 \mu F \quad R_1 = 1 k\Omega \quad C_2 = 100 pF \quad R_2 = 20 k\Omega$$