

## Physics 517/617 - Experiment 6B

### Microcomputers

Since the Intel 8080 was introduced in 1974 the microprocessor has taken over our lives in many ways. They control hardware from home bread machines to automatic water faucets at airports. A modern car is estimated to have more than thirty monitoring and controlling car functions at all times. Microprocessors are circuit elements that fall between electronic hardware and software. They are computers in that they are programmed using algorithmic languages, but they are hardware in that they are installed by being wired into the system with all of the other electronic components

The Basic Stamp II (BS2) is a complete microprocessor (cpu, eeprom, clock...) manufactured by Parallax. Built around the PIC16C57C processor, it is the standard microprocessor used by amateurs and professionals around the U.S.. Parallax simplified the programming by incorporating a basic interpreter in the PIC16C57C rom. The interpreter reads basic commands from an eeprom on the StampII.

The PIC16C57C has 14 multipurpose programmable input/output pins. The Stamp II is slow (~3000 basic commands/second) but is extremely easy to use. It is programmed through a serial port cable, which can also be used for DAQ. A user-friendly PBASIC compiler/editor/loader is freely available on the Parallax web site.

#### 1) Digital Output: How to get started.

An interactive tutorial on your computer (or if you are at home you can install it from the CDROM provided). On the desktop, click on the *basic stamp* folder. Then click on BS2\_Tutorial. You should do the exercises in 3: *BASIC Stamp Editor*, and 4: *Input, Processing, and Output* (Here skip the sections on *Analog Input: RCTIME* and *Frequency Output: FREQOUT*).

Alternatively, if you don't like interactive tutorials you can follow a book. On the desktop, click on the *basic stamp* folder. Then click on the *Document* folder. Open the *student manual* and do the exercises through page 47.

## 2) Interfacing an ADC: How to make “REAL” measurements.

The real world is analog even though modern experiments are typically analyzed digitally. The following circuit will make this analog to digital transition for you. On the Parallax Prototype board construct the following circuit (make sure the power is disconnected from the board).

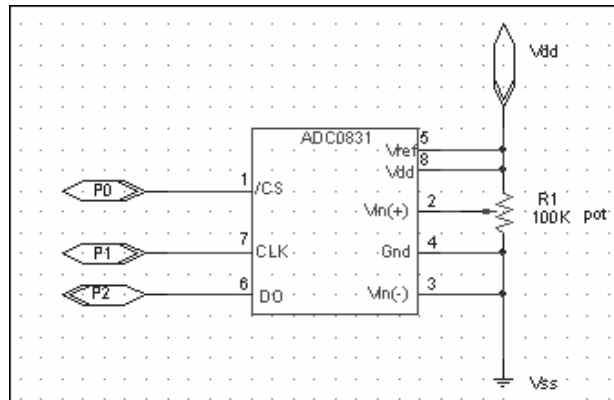

Enter the following program and run it on the Stamp II.

```
('$STAMP BS)
('$PBASIC 2)

ADCBITS VAR BYTE

CS CON 0
CLK CON 1
DO CON 2

C:

HIGH CS
LOW CS
LOW CLK
PULSOUT CLK, 210
SHIFTIN DO, CLK,MSBPOST,[ADCBITS\8]
DEBUG "8-bit binary",BIN8 ADCBITS
DEBUG CR CR,"decimal value",DEC3 ADCBITS

GOTO C
```

The ADC has a built in serial shift register. The High/Low CS/CLK commands start digitization, which stores the ADC value in the shift register. SHIFTIN then shifts the data into the Stamp II ram. Make a plot of the input voltage versus the ADC output. How does one convert ADC bits into voltage? What voltage corresponds to the least significant bit? How accurate is your ADC?

Connect a photodiode-resistor divider into the ADC input. You can now accurately measure the light in the room. Lastly modify the program to make a burglar alarm turn an LED on when the light level drops low (always add a 200  $\Omega$  resistor in series with the LED!). You should include a reset switch in your design.

**Conclusion:** The Stamp II is not a toy. You can purchase one of these units from RadioShack(~\$50) and build complex electronic systems relatively easily. For stand alone circuits LCT displays can be interfaced with a single PBASIC command and are available at a reasonable price. A web search will uncover designs for digital altimeters, weather stations, light meters, infrared transmitter/receivers, RC controls, magnetic detectors... In addition to the simple digital IO above, the Stamp II can generate sinusoidal output to play music as well. There are designs on the web for MIDI devices. It also contains the telephone dialer codes so the Stamp II can phone home. It can also interface devices to a PC through its RS232 port. *The possibilities are limitless.*