



3.3 VOLT HIGH-DENSITY SUPERSYNC II™ 72-BIT FIFO
 512 x 72, 1,024 x 72
 2,048 x 72, 4,096 x 72
 8,192 x 72, 16,384 x 72
 32,768 x 72, 65,536 x 72

PRELIMINARY
 IDT72V7230, IDT72V7240
 IDT72V7250, IDT72V7260
 IDT72V7270, IDT72V7280
 IDT72V7290, IDT72V72100

FEATURES:

- Choose among the following memory organizations:
 - IDT72V7230 — 512 x 72
 - IDT72V7240 — 1,024 x 72
 - IDT72V7250 — 2,048 x 72
 - IDT72V7260 — 4,096 x 72
 - IDT72V7270 — 8,192 x 72
 - IDT72V7280 — 16,384 x 72
 - IDT72V7290 — 32,768 x 72
 - IDT72V72100 — 65,536 x 72
- 100 MHz operation (10 ns read/write cycle time)
- User selectable input and output port bus-sizing
 - x72 in to x72 out
 - x72 in to x36 out
 - x72 in to x18 out
 - x36 in to x72 out
 - x18 in to x72 out
- Big-Endian/Little-Endian user selectable word representation
- Fixed, low first word latency
- Zero latency retransmit
- Auto power down minimizes standby power consumption

- Master Reset clears entire FIFO
- Partial Reset clears data, but retains programmable settings
- Empty, Full and Half-Full flags signal FIFO status
- Programmable Almost-Empty and Almost-Full flags, each flag can default to one of eight preselected offsets
- Selectable synchronous/asynchronous timing modes for Almost-Empty and Almost-Full flags
- Program programmable flags by either serial or parallel means
- Select IDT Standard timing (using EF and FF flags) or First Word Fall Through timing (using OR and IR flags)
- Output enable puts data outputs into high impedance state
- Easily expandable in depth and width
- Independent Read and Write Clocks (permit reading and writing simultaneously)
- Asynchronous operation of Output Enable, OE
- Read Chip Select (RCS) on Read Side
- Available in a 256-pin Fine Pitch Ball Grid Array package (PBGA)
- Features JTAG (Boundary Scan)
- High-performance submicron CMOS technology
- Industrial temperature range (-40°C to +85°C) is available

FUNCTIONAL BLOCK DIAGRAM

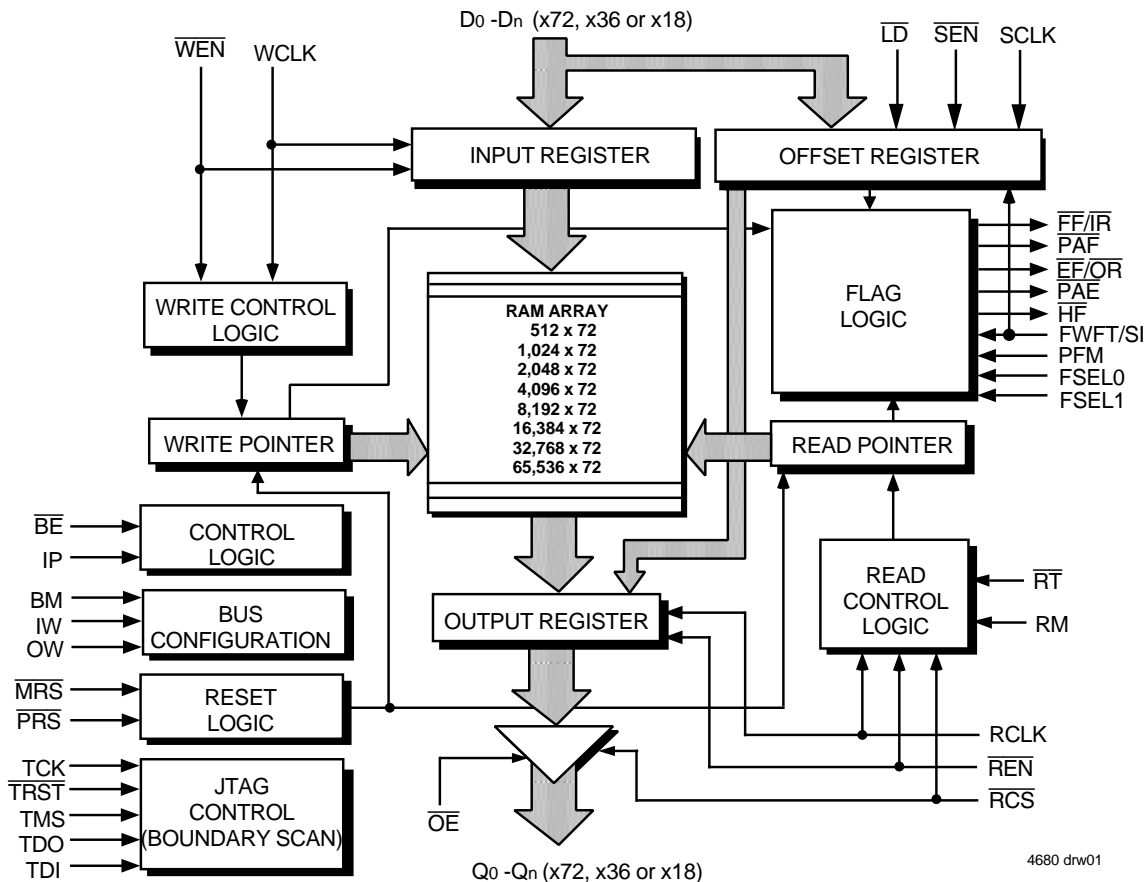

The SuperSync II FIFO is a trademark and the IDT logo is a registered trademark of Integrated Device Technology, Inc.

COMMERCIAL TEMPERATURE RANGE

JANUARY 2001

DESCRIPTION:

The IDT72V7230/72V7240/72V7250/72V7260/72V7270/72V7280/72V7290/72V72100 are exceptionally deep, high speed, CMOS First-In-First-Out (FIFO) memories with clocked read and write controls and a flexible Bus-Matching x72/x36/x18 data flow. These FIFOs offer several key user benefits:

- Flexible x72/x36/x18 Bus-Matching on both read and write ports
- The period required by the retransmit operation is fixed and short.
- The first word data latency period, from the time the first word is written to an empty FIFO to the time it can be read, is fixed and short.
- High density offerings up to 4 Mbit

Bus-Matching Sync FIFOs are particularly appropriate for network, video, telecommunications, data communications and other applications that need to buffer large amounts of data and match busses of unequal sizes.

Each FIFO has a data input port (Dn) and a data output port (Qn), both of which can assume either a 72-bit, 36-bit or a 18-bit width as determined by the state of external control pins Input Width (IW), Output Width (OW), and Bus-Matching (BM) pin during the Master Reset cycle.

The input port is controlled by a Write Clock (WCLK) input and a Write Enable (WEN) input. Data is written into the FIFO on every rising edge of WCLK when WEN is asserted. The output port is controlled by a Read Clock (RCLK) input

PIN CONFIGURATION

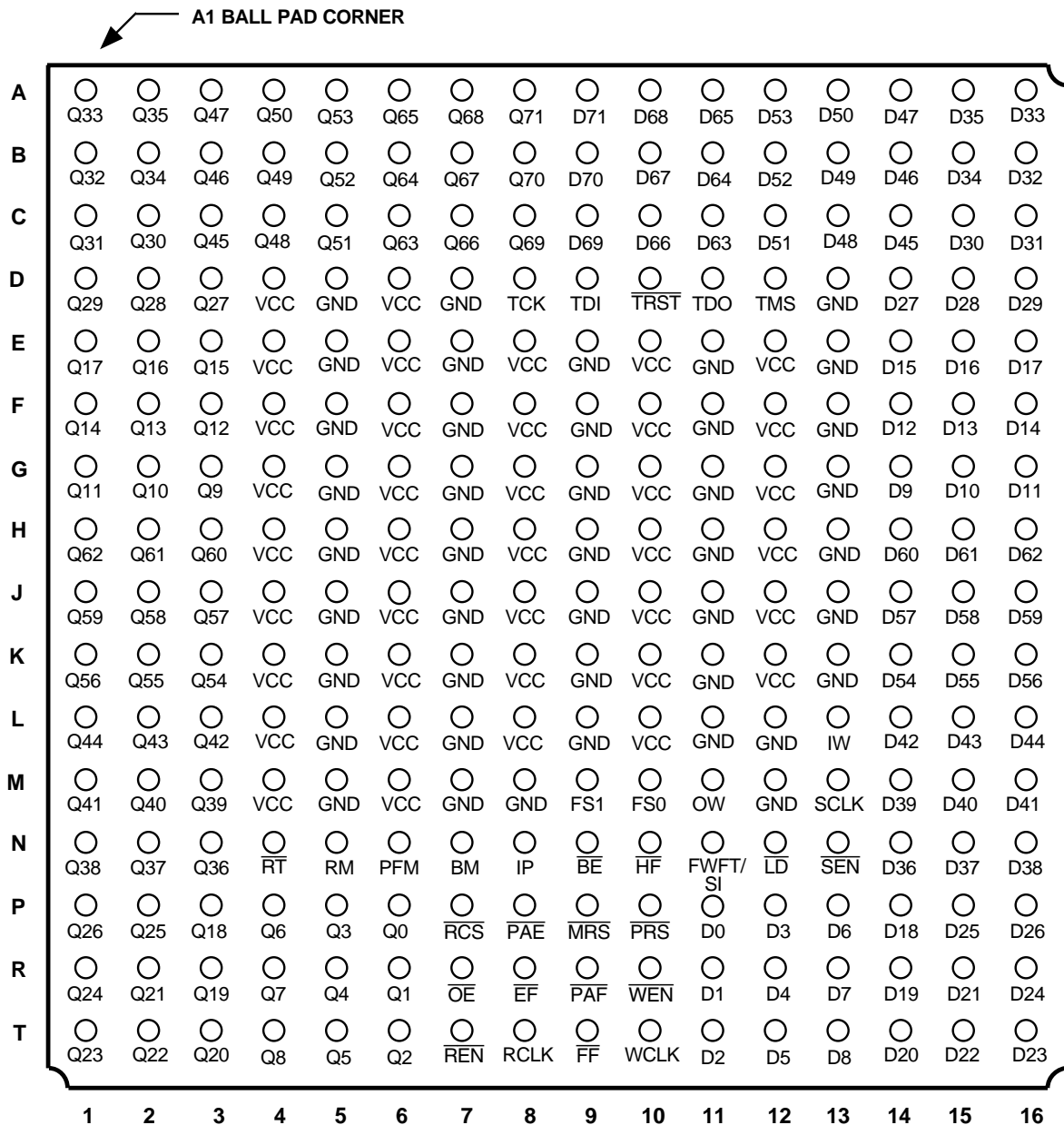

4680 drw02

PBGA (BB256-1, order code: BB)
TOP VIEW

DESCRIPTION (Continued)

and Read Enable (\overline{REN}) input. Data is read from the FIFO on every rising edge of RCLK when \overline{REN} is asserted. An Output Enable (\overline{OE}) input is provided for three-state control of the outputs.

A Read Chip Select (\overline{RCS}) input is also provided for synchronous enable and disable of the read port control input, \overline{REN} . The \overline{RCS} input is synchronized to the read clock, and also provides three-state control of the Q_n outputs. When \overline{RCS} is disabled, \overline{REN} will be disabled internally and output will be three-state.

The frequencies of both the RCLK and the WCLK signals may vary from 0 to f_{MAX} with complete independence. There are no restrictions on the frequency of the one clock input with respect to the other.

There are two possible timing modes of operation with these devices: IDT Standard mode and First Word Fall Through (FWFT) mode.

In *IDT Standard mode*, the first word written to an empty FIFO will not appear on the data output lines unless a specific read operation is performed. A read operation, which consists of activating \overline{REN} and enabling a rising RCLK edge, will shift the word from internal memory to the data output lines.

In *FWFT mode*, the first word written to an empty FIFO is clocked directly to the data output lines after three transitions of the RCLK signal. A \overline{REN} does not have to be asserted for accessing the first word. However, subsequent words written to the FIFO do require a LOW on \overline{REN} for access. The state of the FWFT/SI input during Master Reset determines the timing mode in use.

For applications requiring more data storage capacity than a single FIFO can provide, the FWFT timing mode permits depth expansion by chaining FIFOs

in series (i.e. the data outputs of one FIFO are connected to the corresponding data inputs of the next). No external logic is required.

These FIFOs have five flag pins, $\overline{EF}/\overline{OR}$ (Empty Flag or Output Ready), $\overline{FF}/\overline{IR}$ (Full Flag or Input Ready), \overline{HF} (Half-full Flag), \overline{PAE} (Programmable Almost-Empty flag) and \overline{PAF} (Programmable Almost-Full flag). The \overline{EF} and \overline{FF} functions are selected in IDT Standard mode. The \overline{IR} and \overline{OR} functions are selected in FWFT mode. \overline{HF} , \overline{PAE} and \overline{PAF} are always available for use, irrespective of timing mode.

\overline{PAE} and \overline{PAF} can be programmed independently to switch at any point in memory. Programmable offsets determine the flag switching threshold and can be loaded by two methods: parallel or serial. Eight default offset settings are also provided, so that \overline{PAE} can be set to switch at a predefined number of locations from the empty boundary and the \overline{PAF} threshold can also be set at similar predefined values from the full boundary. The default offset values are set during Master Reset by the state of the FSEL0, FSEL1, and \overline{LD} pins.

For serial programming, \overline{SEN} together with \overline{LD} on each rising edge of SCLK, are used to load the offset registers via the Serial Input (SI). For parallel programming, \overline{WEN} together with \overline{LD} on each rising edge of WCLK, are used to load the offset registers via D_n . \overline{REN} together with \overline{LD} on each rising edge of RCLK can be used to read the offsets in parallel from Q_n regardless of whether serial or parallel offset loading has been selected.

During Master Reset (\overline{MRS}) the following events occur: the read and write pointers are set to the first location of the FIFO. The FWFT pin selects IDT Standard mode or FWFT mode.

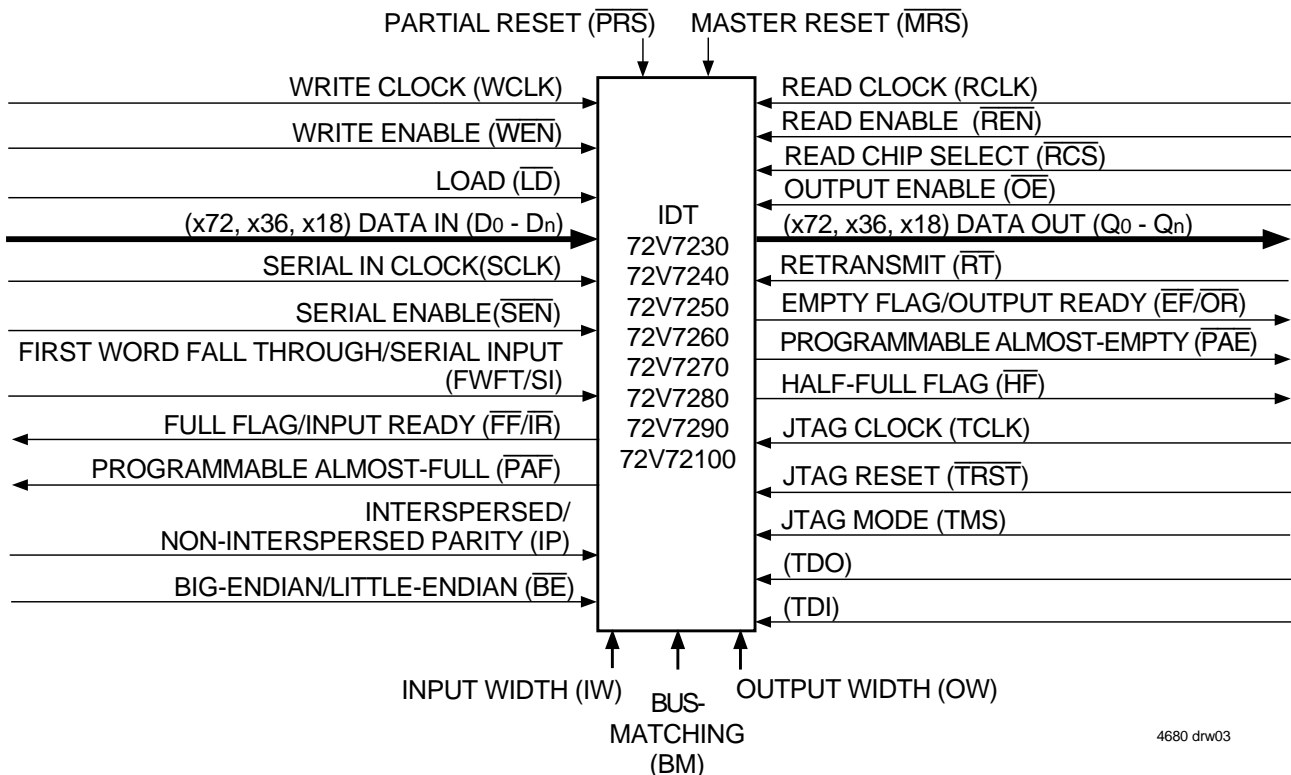

4680 drw03

Figure 1. Single Device Configuration Signal Flow Diagram

The Partial Reset ($\overline{\text{PRS}}$) also sets the read and write pointers to the first location of the memory. However, the timing mode, programmable flag programming method, and default or programmed offset settings existing before Partial Reset remain unchanged. The flags are updated according to the timing mode and offsets in effect. $\overline{\text{PRS}}$ is useful for resetting a device in mid-operation, when reprogramming programmable flags would be undesirable.

It is also possible to select the timing mode of the $\overline{\text{PAE}}$ (Programmable Almost-Empty flag) and $\overline{\text{PAF}}$ (Programmable Almost-Full flag) outputs. The timing modes can be set to be either asynchronous or synchronous for the $\overline{\text{PAE}}$ and $\overline{\text{PAF}}$ flags.

If asynchronous $\overline{\text{PAE}}/\overline{\text{PAF}}$ configuration is selected, the $\overline{\text{PAE}}$ is asserted LOW on the LOW-to-HIGH transition of RCLK. $\overline{\text{PAE}}$ is reset to HIGH on the LOW-to-HIGH transition of WCLK. Similarly, the $\overline{\text{PAF}}$ is asserted LOW on the LOW-to-HIGH transition of WCLK and $\overline{\text{PAF}}$ is reset to HIGH on the LOW-to-HIGH transition of RCLK.

If synchronous $\overline{\text{PAE}}/\overline{\text{PAF}}$ configuration is selected, the $\overline{\text{PAE}}$ is asserted and updated on the rising edge of RCLK only and not WCLK. Similarly, $\overline{\text{PAF}}$ is asserted and updated on the rising edge of WCLK only and not RCLK. The mode desired is configured during master reset by the state of the Programmable Flag Mode (PFM) pin.

The Retransmit function allows data to be reread from the FIFO more than once. A LOW on the $\overline{\text{RT}}$ input during a rising RCLK edge initiates a retransmit operation by setting the read pointer to the first location of the memory array. A zero-latency retransmit timing mode can be selected using the Retransmit timing Mode pin (RM). During Master Reset, a LOW on RM will select zero latency retransmit. A HIGH on RM during Master Reset will select normal latency.

If zero latency retransmit operation is selected, the first data word to be retransmitted will be placed on the output register with respect to the same RCLK edge that initiated the retransmit based on RT being LOW.

Refer to Figure 16 and 17 for *Retransmit Timing* with normal latency. Refer to Figure 18 and 19 for *Zero Latency Retransmit Timing*.

The device can be configured with different input and output bus widths as shown in Table 1.

A Big-Endian/Little-Endian data word format is provided. This function is useful when the FIFO is used in Bus-Matching mode, to determine order of the words. As an example, if Big-Endian mode is selected, then the most significant word of the long word written into the FIFO will be read out of the FIFO first, followed by the least significant word. If Little-Endian format is selected, then the least significant word of the long word written into the FIFO will be read out first, followed by the most significant word. The mode desired is configured during master reset by the state of the Big-Endian ($\overline{\text{BE}}$) pin.

The Interspersed/Non-Interspersed Parity (IP) bit function allows the user to select the parity bit in the word loaded into the parallel port (D0-Dn) when programming the flag offsets. If Interspersed Parity mode is selected, then the FIFO will assume that the parity bit is located in bit position D8 during the parallel programming of the flag offsets. If Non-Interspersed Parity mode is selected, then D8 is assumed to be a valid bit and D16 and D17 are ignored. IP mode is selected during Master Reset by the state of the IP input pin.

If, at any time, the FIFO is not actively performing an operation, the chip will automatically power down. Once in the power down state, the standby supply current consumption is minimized. Initiating any operation (by activating control inputs) will immediately take the device out of the power down state.

Both an Asynchronous Output Enable pin ($\overline{\text{OE}}$) and Synchronous Read Chip Select pin ($\overline{\text{RCS}}$) are provided on the FIFO. The Synchronous Read Chip Select is synchronized to the RCLK. Both the output enable and read chip select control the output buffer of the FIFO, causing the buffer to be either HIGH impedance or LOW impedance. When using $\overline{\text{RCS}}$ the $\overline{\text{OE}}$ pin should be tied LOW. The $\overline{\text{RCS}}$ input also enables or disables the Read Control Inputs, $\overline{\text{REN}}$ and RCLK.

JTAG test pins are also provided, the FIFO has fully functional Boundary Scan feature, compliant with IEEE 1449.1 Standard Test Access Port and Boundary Scan Architecture.

The IDT72V7230/72V7240/72V7250/72V7260/72V7270/72V7280/72V7290/72V72100 are fabricated using IDT's high speed submicron CMOS technology.

TABLE 1 — BUS-MATCHING CONFIGURATION MODES

BM	IW	OW	Write Port Width	Read Port Width
L	X	X	x72	x72
H	H	L	x36	x72
H	H	H	x18	x72
H	L	L	x72	x36
H	L	H	x72	x18

PIN DESCRIPTION

Symbol	Name	I/O	Description
D0–D71	Data Inputs	I	Data inputs for a 72-, 36- or 18-bit bus. When in 36- or 18-bit mode, the unused input pins should be tied LOW.
$\overline{\text{MRS}}$	Master Reset	I	$\overline{\text{MRS}}$ initializes the read and write pointers to zero and sets the output register to all zeroes. During Master Reset, the FIFO is configured for either FWFT or IDT Standard mode, Bus-Matching configurations, one of eight programmable flag default settings, serial or parallel programming of the offset settings, Big-Endian/Little-Endian format, zero latency timing mode, interspersed parity, and synchronous versus asynchronous programmable flag timing modes.
$\overline{\text{PRS}}$	Partial Reset	I	$\overline{\text{PRS}}$ initializes the read and write pointers to zero and sets the output register to all zeroes. During Partial Reset, the existing mode (IDT or FWFT), programming method (serial or parallel), and programmable flag settings are all retained.
$\overline{\text{RT}}$	Retransmit	I	$\overline{\text{RT}}$ asserted on the rising edge of RCLK initializes the READ pointer to zero, sets the $\overline{\text{EF}}$ flag to LOW ($\overline{\text{OR}}$ to HIGH in FWFT mode) and does not disturb the write pointer, programming method, existing timing mode or programmable flag settings. $\overline{\text{RT}}$ is useful to reread data from the first physical location of the FIFO.
FWFT/SI	First Word Fall Through/Serial In	I	During Master Reset, selects First Word Fall Through or IDT Standard mode. After Master Reset, this pin functions as a serial input for loading offset registers.
OW	Output Width	I	This pin, along with IW and BM, selects the bus width of the read port. See Table 1 for bus size configuration.
IW	Input Width	I	This pin, along with OW and BM, selects the bus width of the write port. See Table 1 for bus size configuration.
BM	Bus-Matching	I	BM works with IW and OW to select the bus sizes for both write and read ports. See Table 1 for bus size configuration.
$\overline{\text{BE}}$	Big-Endian/ Little-Endian	I	During Master Reset, a LOW on $\overline{\text{BE}}$ will select Big-Endian operation. A HIGH on BE during Master Reset will select Little-Endian format.
RM	Retransmit Timing Mode	I	During Master Reset, a LOW on RM will select zero latency Retransmit timing Mode. A HIGH on RM will select normal latency mode.
PFM	Programmable Flag Mode	I	During Master Reset, a LOW on PFM will select Asynchronous Programmable flag timing mode. A HIGH on PFM will select Synchronous Programmable flag timing mode.
IP	Interspersed Parity	I	During Master Reset, a LOW on IP will select Non-Interspersed Parity mode. A HIGH will select Interspersed Parity mode.
FSEL0	Flag Select Bit 0	I	During Master Reset, this input along with FSEL1 and the $\overline{\text{LD}}$ pin, will select the default offset values for the programmable flags PAE and PAF. There are up to eight possible settings available.
FSEL1	Flag Select Bit 1	I	During Master Reset, this input along with FSEL0 and the $\overline{\text{LD}}$ pin will select the default offset values for the programmable flags PAE and PAF. There are up to eight possible settings available.
WCLK	Write Clock	I	When enabled by $\overline{\text{WEN}}$, the rising edge of WCLK writes data into the FIFO and offsets into the programmable registers for parallel programming.
$\overline{\text{WEN}}$	Write Enable	I	$\overline{\text{WEN}}$ enables WCLK for writing data into the FIFO memory and offset registers.
RCLK	Read Clock	I	When enabled by $\overline{\text{REN}}$, the rising edge of RCLK reads data from the FIFO memory and offsets from the programmable registers. ($\overline{\text{RCS}}$ must be active).
$\overline{\text{REN}}$	Read Enable	I	$\overline{\text{REN}}$ enables RCLK for reading data from the FIFO memory and offset registers. ($\overline{\text{RCS}}$ must be active).
$\overline{\text{OE}}$	Output Enable	I	$\overline{\text{OE}}$ provides asynchronous control of the output impedance of Qn.
$\overline{\text{RCS}}$	Read Chip Select	I	$\overline{\text{RCS}}$ provides synchronous control of the read port and output impedance of Qn, synchronous to RCLK. When using $\overline{\text{RCS}}$ the $\overline{\text{OE}}$ pin must be tied LOW.
SCLK	Serial Input Clock	I	when enabled by $\overline{\text{SEN}}$, the rising edge of SCLK writes one bit of data (present on the SI input), into the programmable register for serial programming.
$\overline{\text{SEN}}$	Serial Enable	I	$\overline{\text{SEN}}$ enables serial loading of programmable flag offsets.
$\overline{\text{LD}}$	Load	I	This is a dual purpose pin. During Master Reset, the state of the $\overline{\text{LD}}$ input along with FSEL0 and FSEL1, determines one of eight default offset values for the PAE and PAF flags, along with the method by which these offset registers can be programmed, parallel or serial (see Table 2). After Master Reset, this pin enables writing to and reading from the offset registers.
$\overline{\text{FF}}/\overline{\text{IR}}$	Full Flag/ Input Ready	O	In the IDT Standard mode, the $\overline{\text{FF}}$ function is selected. $\overline{\text{FF}}$ indicates whether or not the FIFO memory is full. In the FWFT mode, the $\overline{\text{IR}}$ function is selected. $\overline{\text{IR}}$ indicates whether or not there is space available for writing to the FIFO memory.

PIN DESCRIPTION (Continued)

Symbol	Name	I/O	Description
$\overline{EF}/\overline{OR}$	Empty Flag/ Output Ready	O	In the IDT Standard mode, the \overline{EF} function is selected. \overline{EF} indicates whether or not the FIFO memory is empty. In FWT mode, the \overline{OR} function is selected. \overline{OR} indicates whether or not there is valid data available at the outputs.
\overline{PAF}	Programmable Almost-Full Flag	O	\overline{PAF} goes HIGH if the number of free locations in the FIFO memory is more than offset m, which is stored in the Full Offset register. \overline{PAF} goes LOW if the number of free locations in the FIFO memory is less than or equal to m.
\overline{PAE}	Programmable Almost-Empty	O	\overline{PAE} goes LOW if the number of words in the FIFO memory is less than offset n, which is stored in the Empty Offset register. \overline{PAE} goes HIGH if the number of Flag words in the FIFO memory is greater than or equal to offset n.
\overline{HF}	Half-Full Flag	O	\overline{HF} indicates whether the FIFO memory is more or less than half-full.
Q0–Q71	Data Outputs	O	Data outputs for an 72-, 36- or 18-bit bus. When in 36- or 18-bit mode, the unused output pins should not be connected. Data Outputs are not 5V tolerant regardless of the state of the \overline{OE} and \overline{RCS} .
TCK ⁽¹⁾	JTAG Clock	I	Clock input for JTAG function. TMS and TDI are sampled on the rising edge. TDO is output on the falling edge.
\overline{TRST} ⁽¹⁾	JTAG Reset	I	\overline{TRST} is the asynchronous reset pin for the JTAG controller.
TMS	JTAG Mode Select	I	TMS is a serial input pin. Bits are serially loaded on the rising edge of TCK, which selects 1 of 5 modes of operation for the JTAG boundary scan.
TDI	Test Data Input	I	During JTAG boundary scan operation test data is serially loaded via TDI on the rising edge of TCK. This is also the data for the Instruction Register, ID Register and Bypass Register.
TDO	Test Data Output	O	During JTAG boundary scan operation test data is serially output via TDO on the falling edge of TCK. This output is in High-Z except when shifting while in SHIFT-DR and SHIFT-IR controller states.

NOTE:

1. If the JTAG feature is not being used, TCK and \overline{TRST} should be tied LOW.

ABSOLUTE MAXIMUM RATINGS

Symbol	Rating	Commercial	Unit
V _{TERM}	Terminal Voltage with respect to GND	-0.5 to +4.5	V
T _{STG}	Storage Temperature	-55 to +125	°C
I _{OUT}	DC Output Current	-50 to +50	mA

NOTE:

- Stresses greater than those listed under ABSOLUTE MAXIMUM RATINGS may cause permanent damage to the device. This is a stress rating only and functional operation of the device at these or any other conditions above those indicated in the operational sections of this specification is not implied. Exposure to absolute maximum rating conditions for extended periods may affect reliability.

RECOMMENDED DC OPERATING CONDITIONS

Symbol	Parameter	Min.	Typ.	Max.	Unit
V _{CC}	Supply Voltage	3.15	3.3	3.45	V
GND	Supply Voltage	0	0	0	V
V _{IH}	Input High Voltage	2.0	—	V _{CC} +0.3	V
V _{IL} ⁽¹⁾	Input Low Voltage	—	—	0.8	V
T _A	Operating Temperature Commercial	0	—	70	°C

NOTES:

- V_{CC} = 3.3V ± 0.15V, JEDEC JESD8-A compliant.
- 1.5V undershoots are allowed for 10ns once per cycle.

DC ELECTRICAL CHARACTERISTICS(Commercial: V_{CC} = 3.3V ± 0.15V, T_A = 0°C to +70°C; JEDEC JESD8-A compliant)

Symbol	Parameter	IDT72V7230L IDT72V7240L IDT72V7250L IDT72V7260L IDT72V7270L IDT72V7280L IDT72V7290L IDT72V72100L Commercial t _{CLK} = 10, 15 ns		Unit
		Min.	Max.	
I _{LI} ⁽¹⁾	Input Leakage Current	-10	10	μA
I _{LO} ⁽²⁾	Output Leakage Current	-10	10	μA
V _{OH}	Output Logic "1" Voltage, I _{OH} = -2 mA	2.4	—	V
V _{OL}	Output Logic "0" Voltage, I _{OL} = 4 mA	—	0.4	V
I _{CC1} ^(3,4,5)	Active Power Supply Current	—	75	mA
I _{CC2} ^(3,6)	Standby Current	—	15	mA

NOTES:

- Measurements with $0.4 \leq V_{IN} \leq V_{CC}$.
- $\overline{OE} \geq V_{IH}$, $0.4 \leq V_{OUT} \leq V_{CC}$.
- Tested with outputs open (I_{OUT} = 0).
- RCLK and WCLK toggle at 20 MHz and data inputs switch at 10 MHz.
- Typical I_{CC1} = 15.5 + 2.275*fs + 0.02*CL*fs (in mA) with V_{CC} = 3.3V, t_A = 25°C, fs = WCLK frequency = RCLK frequency (in MHz, using TTL levels), data switching at fs/2, CL = capacitive load (in pF).
- All Inputs = V_{CC} - 0.2V or GND + 0.2V, except RCLK and WCLK, which toggle at 20 MHz.

CAPACITANCE (T_A = +25°C, f = 1.0MHz)

Symbol	Parameter ⁽¹⁾	Conditions	Max.	Unit
C _{IN} ⁽²⁾	Input Capacitance	V _{IN} = 0V	10	pF
C _{OUT} ^(1,2)	Output Capacitance	V _{OUT} = 0V	10	pF

NOTES:

- With output deselected, ($\overline{OE} \geq V_{IH}$).
- Characterized values, not currently tested.

AC ELECTRICAL CHARACTERISTICS⁽¹⁾

(Commercial: VCC = 3.3V ± 0.15V, TA = 0°C to +70°C; JEDEC JESD8-A compliant)

Symbol	Parameter	Commercial				Unit
		IDT72V7230L10 IDT72V7240L10 IDT72V7250L10 IDT72V7260L10 IDT72V7270L10 IDT72V7280L10 IDT72V7290L10 IDT72V72100L10		IDT72V7230L15 IDT72V7240L15 IDT72V7250L15 IDT72V7260L15 IDT72V7270L15 IDT72V7280L15 IDT72V7290L15 IDT72V72100L15		
		Min.	Max.	Min.	Max.	
fs	Clock Cycle Frequency	—	100	—	66.7	MHz
tA	Data Access Time	1	6.5	1	10	ns
tCLK	Clock Cycle Time	10	—	15	—	ns
tCLKH	Clock High Time	4.5	—	6	—	ns
tCLKL	Clock Low Time	4.5	—	6	—	ns
tDS	Data Setup Time	3.5	—	4	—	ns
tDH	Data Hold Time	0.5	—	1	—	ns
tENS	Enable Setup Time	3.5	—	4	—	ns
tENH	Enable Hold Time	0.5	—	1	—	ns
tLDS	Load Setup Time	3.5	—	4	—	ns
tLDH	Load Hold Time	0.5	—	1	—	ns
tRS	Reset Pulse Width ⁽²⁾	10	—	15	—	ns
tRSS	Reset Setup Time	10	—	15	—	ns
tRSR	Reset Recovery Time	10	—	15	—	ns
tRSF	Reset to Flag and Output Time	—	15	—	15	ns
tFWFT	Mode Select Time	0	—	0	—	ns
tRTS	Retransmit Setup Time	3.5	—	4	—	ns
tOLZ	Output Enable to Output in Low Z ⁽³⁾	1	—	1	—	ns
tOE	Output Enable to Output Valid	1	6	1	8	ns
tOHZ	Output Enable to Output in High Z ⁽³⁾	1	6	1	8	ns
tWFF	Write Clock to FF or IR	—	6.5	—	10	ns
tREF	Read Clock to EF or OR	—	6.5	—	10	ns
tPAFA	Clock to Asynchronous Programmable Almost-Full Flag	—	16	—	20	ns
tPAFS	Write Clock to Synchronous Programmable Almost-Full Flag	—	6.5	—	10	ns
tPAEA	Clock to Asynchronous Programmable Almost-Empty Flag	—	16	—	20	ns
tPAES	Read Clock to Synchronous Programmable Almost-Empty Flag	—	6.5	—	10	ns
tHF	Clock to HF	—	16	—	20	ns
tRCS	RCS Setup Time	3.5	—	5	—	ns
tRCSH	RCS Hold Time	0.5	—	1	—	ns
tRCSLZ	RCLK to Active from High-Z ⁽³⁾	1	6.5	1	10	ns
tRCSHZ	RCLK to High-Z ⁽³⁾	1	6.5	1	10	ns
tSKEW1	Skew time between RCLK and WCLK for EF/OR and FF/IR	7	—	9	—	ns
tSKEW2	Skew time between RCLK and WCLK for PAE and PAF	10	—	14	—	ns

NOTES:

- All AC timings apply to both Standard IDT mode and First Word Fall Through mode.
- Pulse widths less than minimum values are not allowed.
- Values guaranteed by design, not currently tested.
- Data Sheet slow conditions: 85°C, 3.0V. Data Sheet fast conditions: -40°C, 3.6V.

AC TEST CONDITIONS

Input Pulse Levels	GND to 3.0V
Input Rise/Fall Times	3ns
Input Timing Reference Levels	1.5V
Output Reference Levels	1.5V
Output Load	See Figure 2

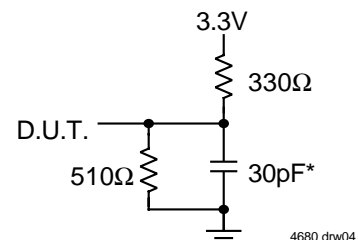

Figure 2. Output Load

* Includes jig and scope capacitances

FUNCTIONAL DESCRIPTION

TIMING MODES: IDT STANDARD vs FIRST WORD FALL THROUGH (FWFT) MODE

The IDT72V7230/72V7240/72V7250/72V7260/72V7270/72V7280/72V7290/72V72100 support two different timing modes of operation: IDT Standard mode or First Word Fall Through (FWFT) mode. The selection of which mode will operate is determined during Master Reset, by the state of the FWFT/SI input.

If, at the time of Master Reset, FWFT/SI is LOW, then IDT Standard mode will be selected. This mode uses the Empty Flag (\overline{EF}) to indicate whether or not there are any words present in the FIFO. It also uses the Full Flag function (\overline{FF}) to indicate whether or not the FIFO has any free space for writing. In IDT Standard mode, every word read from the FIFO, including the first, must be requested using the Read Enable (\overline{REN}) and RCLK.

If, at the time of Master Reset, FWFT/SI is HIGH, then FWFT mode will be selected. This mode uses Output Ready (\overline{OR}) to indicate whether or not there is valid data at the data outputs (Q_n). It also uses Input Ready (\overline{IR}) to indicate whether or not the FIFO has any free space for writing. In the FWFT mode, the first word written to an empty FIFO goes directly to Q_n after three RCLK rising edges, $\overline{REN} = \text{LOW}$ is not necessary. Subsequent words must be accessed using the Read Enable (\overline{REN}) and RCLK.

Various signals, both input and output signals operate differently depending on which timing mode is in effect.

IDT STANDARD MODE

In this mode, the status flags, \overline{FF} , \overline{PAF} , \overline{HF} , \overline{PAE} , and \overline{EF} operate in the manner outlined in Table 3. To write data into the FIFO, Write Enable (\overline{WEN}) must be LOW. Data presented to the DATA IN lines will be clocked into the FIFO on subsequent transitions of the Write Clock (WCLK). After the first write is performed, the Empty Flag (\overline{EF}) will go HIGH. Subsequent writes will continue to fill up the FIFO. The Programmable Almost-Empty flag (\overline{PAE}) will go HIGH after $n + 1$ words have been loaded into the FIFO, where n is the empty offset value. The default setting for these values are stated in the footnote of Table 2. This parameter is also user programmable. See section on Programmable Flag Offset Loading.

If one continued to write data into the FIFO, and we assumed no read operations were taking place, the Half-Full flag (\overline{HF}) would toggle to LOW once the 257th word for IDT72V7230, 513rd word for IDT72V7240, 1,025th word for IDT72V7250, 2,049th word for IDT72V7260, 4,097th word for IDT72V7270, 8,193th word for the IDT72V7280, 16,385th word for the IDT72V7290 and 32,769th word for the IDT72V72100, respectively was written into the FIFO. Continuing to write data into the FIFO will cause the Programmable Almost-Full flag (\overline{PAF}) to go LOW. Again, if no reads are performed, the \overline{PAF} will go LOW after (512- m) writes for the IDT72V7230, (1,024- m) writes for the IDT72V7240, (2,048- m) writes for the IDT72V7250, (4,096- m) writes for the IDT72V7260, (8,192- m) writes for the IDT72V7270, (16,384- m) writes for the IDT72V7280, (32,768- m) writes for the IDT72V7290 and (65,536- m) writes for the IDT72V72100. The offset "m" is the full offset value. The default setting for these values are stated in the footnote of Table 2. This parameter is also user programmable. See section on Programmable Flag Offset Loading.

When the FIFO is full, the Full Flag (\overline{FF}) will go LOW, inhibiting further write operations. If no reads are performed after a reset, \overline{FF} will go LOW after D writes to the FIFO. $D = 512$ writes for the IDT72V7230, 1,024 writes for the IDT72V7240, 2,048 writes for the IDT72V7250, 4,096 writes for the IDT72V7260, 8,192 writes for the IDT72V7270, 16,384 writes for the IDT72V7280, 32,768 writes for the IDT72V7290, 65,536 writes for the IDT72V72100, respectively.

If the FIFO is full, the first read operation will cause \overline{FF} to go HIGH. Subsequent read operations will cause \overline{PAF} and \overline{HF} to go HIGH at the conditions described in Table 3. If further read operations occur, without write operations, \overline{PAE} will go LOW when there are n words in the FIFO, where n is the empty offset value. Continuing read operations will cause the FIFO to become empty. When the last word has been read from the FIFO, the \overline{EF} will go LOW inhibiting further read operations. \overline{REN} is ignored when the FIFO is empty.

When configured in IDT Standard mode, the \overline{EF} and \overline{FF} outputs are double register-buffered outputs.

Relevant timing diagrams for IDT Standard mode can be found in Figure 10, 11, 12, 16 and 18.

FIRST WORD FALL THROUGH MODE (FWFT)

In this mode, the status flags, \overline{IR} , \overline{PAF} , \overline{HF} , \overline{PAE} , and \overline{OR} operate in the manner outlined in Table 4. To write data into the FIFO, \overline{WEN} must be LOW. Data presented to the DATA IN lines will be clocked into the FIFO on subsequent transitions of WCLK. After the first write is performed, the Output Ready (\overline{OR}) flag will go LOW. Subsequent writes will continue to fill up the FIFO. \overline{PAE} will go HIGH after $n + 2$ words have been loaded into the FIFO, where n is the empty offset value. The default setting for these values are stated in the footnote of Table 2. This parameter is also user programmable. See section on Programmable Flag Offset Loading.

If one continued to write data into the FIFO, and we assumed no read operations were taking place, the \overline{HF} would toggle to LOW once the 258th word for the IDT72V7230, 514th word for the IDT72V7240, 1,026th word for the IDT72V7250, 2,050th word for the IDT72V7260, 4,098th word for the IDT72V7270, 8,194th word for the IDT72V7280, 16,386th word for the IDT72V7290 and 32,770th word for the IDT72V72100, respectively was written into the FIFO. Continuing to write data into the FIFO will cause the \overline{PAF} to go LOW. Again, if no reads are performed, the \overline{PAF} will go LOW after (513- m) writes for the IDT72V7230, (1,025- m) writes for the IDT72V7240, (2,049- m) writes for the IDT72V7250, (4,097- m) writes for the IDT72V7260 and (8,193- m) writes for the IDT72V7270, 16,385 writes for the IDT72V7280, 32,769 writes for the IDT72V7290 and 65,537 writes for the IDT72V72100, where m is the full offset value. The default setting for these values are stated in the footnote of Table 2.

When the FIFO is full, the Input Ready (\overline{IR}) flag will go HIGH, inhibiting further write operations. If no reads are performed after a reset, \overline{IR} will go HIGH after D writes to the FIFO. $D = 513$ writes for the IDT72V7230, 1,025 writes for the IDT72V7240, 2,049 writes for the IDT72V7250, 4,097 writes for the IDT72V7260 and 8,193 writes for the IDT72V7270, 16,385 writes for the IDT72V7280, 32,769 writes for the IDT72V7290, 65,537 writes for the IDT72V72100, respectively. Note that the additional word in FWFT mode is due to the capacity of the memory plus output register.

If the FIFO is full, the first read operation will cause the \overline{IR} flag to go LOW. Subsequent read operations will cause the \overline{PAF} and \overline{HF} to go HIGH at the conditions described in Table 4. If further read operations occur, without write operations, the \overline{PAE} will go LOW when there are $n + 1$ words in the FIFO, where n is the empty offset value. Continuing read operations will cause the FIFO to become empty. When the last word has been read from the FIFO, \overline{OR} will go HIGH inhibiting further read operations. \overline{REN} is ignored when the FIFO is empty.

When configured in FWFT mode, the \overline{OR} flag output is triple register-buffered, and the \overline{IR} flag output is double register-buffered.

Relevant timing diagrams for FWFT mode can be found in Figure 13, 14, 15, 17, and 19.

TABLE 2 — DEFAULT PROGRAMMABLE FLAG OFFSETS

IDT72V7230, 72V7240			
$\overline{\text{LD}}$	FSEL1	FSEL0	Offsets n,m
L	H	L	511
L	L	H	255
L	L	L	127
L	H	H	63
H	L	L	31
H	H	L	15
H	L	H	7
H	H	H	3
$\overline{\text{LD}}$	FSEL1	FSEL0	Program Mode
H	X	X	Serial ⁽³⁾
L	X	X	Parallel ⁽⁴⁾
IDT72V7250, 72V7260, 72V7270, 72V7280			
$\overline{\text{LD}}$	FSEL1	FSEL0	Offsets n,m
H	L	L	1,023
L	H	L	511
L	L	H	255
L	L	L	127
L	H	H	63
H	H	L	31
H	L	H	15
H	H	H	7
$\overline{\text{LD}}$	FSEL1	FSEL0	Program Mode
H	X	X	Serial ⁽³⁾
L	X	X	Parallel ⁽⁴⁾
IDT72V7290, 72V72100			
$\overline{\text{LD}}$	FSEL1	FSEL0	Offsets n,m
L	H	L	16,383
L	L	H	8,191
L	H	H	4,095
H	H	L	2,047
H	L	L	1,023
H	L	H	511
H	H	H	255
L	L	L	127
$\overline{\text{LD}}$	FSEL1	FSEL0	Program Mode
H	X	X	Serial ⁽³⁾
L	X	X	Parallel ⁽⁴⁾

NOTES:

1. n = empty offset for $\overline{\text{PAE}}$.
2. m = full offset for $\overline{\text{PAF}}$.
3. As well as selecting serial programming mode, one of the default values will also be loaded depending on the state of FSEL0 & FSEL1.
4. As well as selecting parallel programming mode, one of the default values will also be loaded depending on the state of FSEL0 & FSEL1.

PROGRAMMING FLAG OFFSETS

Full and Empty Flag offset values are user programmable. The IDT72V7230/72V7240/72V7250/72V7260/72V7270/72V7280/72V7290/72V72100 have internal registers for these offsets. There are eight default offset values selectable during Master Reset. These offset values are shown in Table 2. Offset values can also be programmed into the FIFO in one of two ways; serial or parallel loading method. The selection of the loading method is done using the $\overline{\text{LD}}$ (Load) pin. During Master Reset, the state of the $\overline{\text{LD}}$ input determines whether serial or parallel flag offset programming is enabled. A HIGH on $\overline{\text{LD}}$ during Master Reset selects serial loading of offset values. A LOW on $\overline{\text{LD}}$ during Master Reset selects parallel loading of offset values.

In addition to loading offset values into the FIFO, it is also possible to read the current offset values. Offset values can be read via the parallel output port Q0-Qn, regardless of the programming mode selected (serial or parallel). It is not possible to read the offset values in serial fashion.

Figure 3, *Programmable Flag Offset Programming Sequence*, summarizes the control pins and sequence for both serial and parallel programming modes. For a more detailed description, see discussion that follows.

The offset registers may be programmed (and reprogrammed) any time after Master Reset, regardless of whether serial or parallel programming has been selected. Valid programming ranges are from 0 to D-1.

SYNCHRONOUS vs ASYNCHRONOUS PROGRAMMABLE FLAG TIMING SELECTION

The IDT72V7230/72V7240/72V7250/72V7260/72V7270/72V7280/72V7290/72V72100 can be configured during the Master Reset cycle with either synchronous or asynchronous timing for $\overline{\text{PAF}}$ and $\overline{\text{PAE}}$ flags by use of the PFM pin.

If synchronous $\overline{\text{PAF}}$ / $\overline{\text{PAE}}$ configuration is selected (PFM, HIGH during $\overline{\text{MRS}}$), the $\overline{\text{PAF}}$ is asserted and updated on the rising edge of WCLK only and not RCLK. Similarly, $\overline{\text{PAE}}$ is asserted and updated on the rising edge of RCLK only and not WCLK. For detail timing diagrams, see Figure 23 for synchronous $\overline{\text{PAF}}$ timing and Figure 24 for synchronous $\overline{\text{PAE}}$ timing.

If asynchronous $\overline{\text{PAF}}$ / $\overline{\text{PAE}}$ configuration is selected (PFM, LOW during $\overline{\text{MRS}}$), the $\overline{\text{PAF}}$ is asserted LOW on the LOW-to-HIGH transition of WCLK and $\overline{\text{PAF}}$ is reset to HIGH on the LOW-to-HIGH transition of RCLK. Similarly, $\overline{\text{PAE}}$ is asserted LOW on the LOW-to-HIGH transition of RCLK. $\overline{\text{PAE}}$ is reset to HIGH on the LOW-to-HIGH transition of WCLK. For detail timing diagrams, see Figure 25 for asynchronous $\overline{\text{PAF}}$ timing and Figure 26 for asynchronous $\overline{\text{PAE}}$ timing.

TABLE 3 — STATUS FLAGS FOR IDT STANDARD MODE

Number of Words in FIFO	IDT72V7230	IDT72V7240	IDT72V7250	IDT72V7260	FF	PAF	HF	PAE	EF
	0	0	0	0	H	H	H	L	L
	1 to n ⁽¹⁾	1 to n ⁽¹⁾	1 to n ⁽¹⁾	1 to n ⁽¹⁾	H	H	H	L	H
	(n+1) to 256	(n+1) to 512	(n+1) to 1,024	(n+1) to 2,048	H	H	H	H	H
	257 to (512-(m+1))	513 to (1,024-(m+1))	1,025 to (2,048-(m+1))	2,049 to (4,096-(m+1))	H	H	L	H	H
	(512-m) to 511	(1,024-m) to 1,023	(2,048-m) to 2,047	(4,096-m) to 4,095	H	L	L	H	H
	512	1,024	2,048	4,096	L	L	L	H	H

Number of Words in FIFO	IDT72V7270	IDT72V7280	IDT72V7290	IDT72V72100	FF	PAF	HF	PAE	EF
	0	0	0	0	H	H	H	L	L
	1 to n ⁽¹⁾	1 to n ⁽¹⁾	1 to n ⁽¹⁾	1 to n ⁽¹⁾	H	H	H	L	H
	(n+1) to 4,096	(n+1) to 8,192	(n+1) to 16,384	(n+1) to 32,768	H	H	H	H	H
	4,097 to (8,192-(m+1))	8,193 to (16,384-(m+1))	16,385 to (32,768-(m+1))	32,769 to (65,536-(m+1))	H	H	L	H	H
	(8,192-m) to 8,191	(16,384-m) to 16,383	(32,768-m) to 32,767	(65,536-m) to 65,535	H	L	L	H	H
8,192	16,384	32,768	65,536	L	L	L	H	H	

NOTE:
 1. See table 2 for values for n, m.

TABLE 4 — STATUS FLAGS FOR FWFT MODE

Number of Words in FIFO	IDT72V7230	IDT72V7240	IDT72V7250	IDT72V7260	IR	PAF	HF	PAE	OR
	0	0	0	0	L	H	H	L	H
	1 to n+1	1 to n+1	1 to n+1	1 to n+1	L	H	H	L	L
	(n+2) to 257	(n+2) to 513	(n+2) to 1,025	(n+2) to 2,049	L	H	H	H	L
	258 to (513-(m+1))	514 to (1,025-(m+1))	1,026 to (2,049-(m+1))	2,050 to (4,097-(m+1))	L	H	L	H	L
	(513-m) to 512	(1,025-m) to 1,024	(2,049-m) to 2,048	(4,097-m) to 4,096	L	L	L	H	L
513	1,025	2,049	4,097	H	L	L	H	L	

Number of Words in FIFO	IDT72V7270	IDT72V7280	IDT72V7290	IDT72V72100	IR	PAF	HF	PAE	OR
	0	0	0	0	L	H	H	L	H
	1 to n+1	1 to n+1	1 to n+1	1 to n+1	L	H	H	L	L
	(n+2) to 4,097	(n+2) to 8,193	(n+2) to 16,385	(n+2) to 32,769	L	H	H	H	L
	4,098 to (8,193-(m+1))	8,194 to (16,385-(m+1))	16,386 to (32,769-(m+1))	32,770 to (65,537-(m+1))	L	H	L	H	L
	(8,193-m) to 8,192	(16,385-m) to 16,384	(32,769-m) to 32,768	(65,537-m) to 65,536	L	L	L	H	L
8,193	16,385	32,769	65,537	H	L	L	H	L	

NOTE:
 1. See table 2 for values for n, m.

$\overline{\text{LD}}$	$\overline{\text{WEN}}$	$\overline{\text{REN}}$	$\overline{\text{SEN}}$	WCLK	RCLK	SCLK	IDT72V7230 IDT72V7240 IDT72V7250 IDT72V7260 IDT72V7270 IDT72V7280 IDT72V7290 IDT72V72100
0	0	1	1		X	X	Parallel write to registers: Empty Offset Full Offset
0	1	0	1	X		X	Parallel read from registers: Empty Offset Full Offset
0	1	1	0	X	X		Serial shift into registers: 18 bits for the IDT72V7230 20 bits for the IDT72V7240 22 bits for the IDT72V7250 24 bits for the IDT72V7260 26 bits for the IDT72V7270 28 bits for the IDT72V7280 30 bits for the IDT72V7290 32 bits for the IDT72V72100 1 bit for each rising WCLK edge Starting with Empty Offset (LSB) Ending with Full Offset (MSB)
X	1	1	1	X	X	X	No Operation
1	0	X	X		X	X	Write Memory
1	X	0	X	X		X	Read Memory
1	1	1	X	X	X	X	No Operation

NOTES:

1. The programming method can only be selected at Master Reset.
2. Parallel reading of the offset registers is always permitted regardless of which programming method has been selected.
3. The programming sequence applies to both IDT Standard and FWFT modes.

4680 drw06

Figure 3. Programmable Flag Offset Programming Sequence

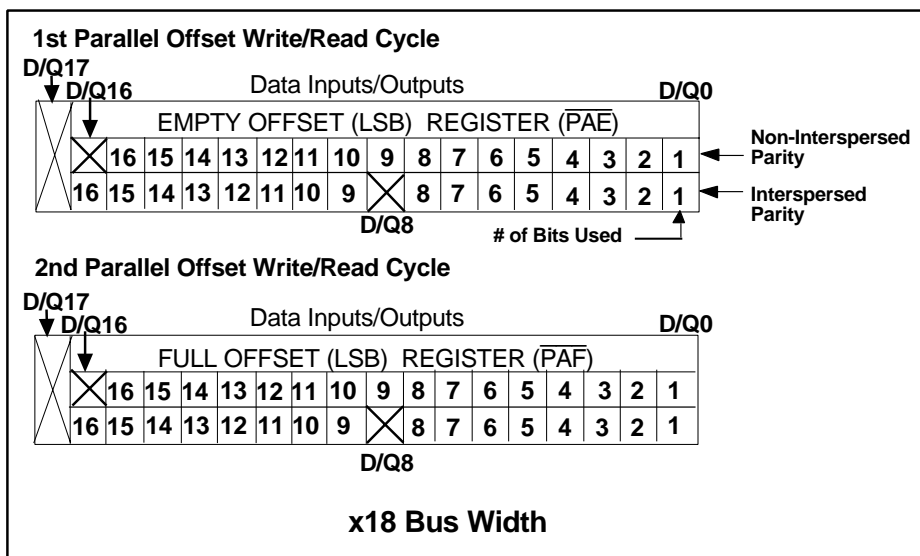
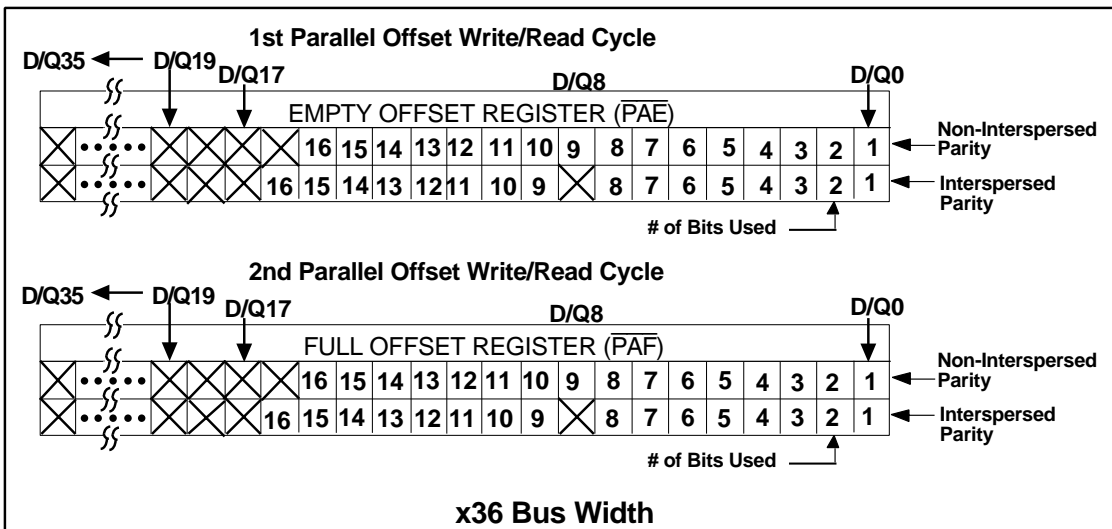
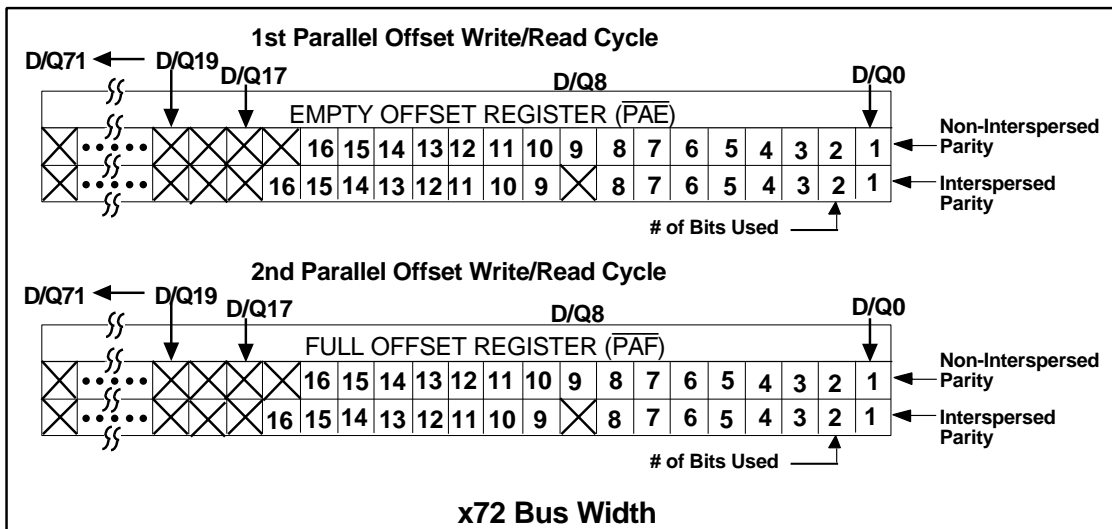

of Bits Used:
 09 bits for the IDT72V7230
 10 bits for the IDT72V7240
 11 bits for the IDT72V7250
 12 bits for the IDT72V7260
 13 bits for the IDT72V7270
 14 bits for the IDT72V7280
 15 bits for the IDT72V7290
 16 bits for the IDT72V72100
 Note: All unused input bits are don't care.

4680 drw07

Figure 3. Programmable Flag Offset Programming Sequence (Continued)

FUNCTIONAL DESCRIPTION (Continued)

SERIAL PROGRAMMING MODE

If Serial Programming mode has been selected, as described above, then programming of PAE and PAF values can be achieved by using a combination of the $\overline{\text{LD}}$, $\overline{\text{SEN}}$, $\overline{\text{SCLK}}$ and $\overline{\text{SI}}$ input pins. Programming PAE and PAF proceeds as follows: when $\overline{\text{LD}}$ and $\overline{\text{SEN}}$ are set LOW, data on the $\overline{\text{SI}}$ input are written, one bit for each $\overline{\text{SCLK}}$ rising edge, starting with the Empty Offset LSB and ending with the Full Offset MSB. A total of 18 bits for the IDT72V7230, 20 bits for the IDT72V7240, 22 bits for the IDT72V7250, 24 bits for the IDT72V7260, 26 bits for the IDT72V7270, 28 bits for the IDT72V7280, 30 bits for the IDT72V7290 and 32 bits for the IDT72V72100. See Figure 20, *Serial Loading of Programmable Flag Registers*, for the timing diagram for this mode.

Using the serial method, individual registers cannot be programmed selectively. PAE and PAF can show a valid status only after the complete set of bits (for all offset registers) has been entered. The registers can be reprogrammed as long as the complete set of new offset bits is entered. When $\overline{\text{LD}}$ is LOW and $\overline{\text{SEN}}$ is HIGH, no serial write to the registers can occur.

Write operations to the FIFO are allowed before and during the serial programming sequence. In this case, the programming of all offset bits does not have to occur at once. A select number of bits can be written to the $\overline{\text{SI}}$ input and then, by bringing $\overline{\text{LD}}$ and $\overline{\text{SEN}}$ HIGH, data can be written to FIFO memory via $\overline{\text{Dn}}$ by toggling $\overline{\text{WEN}}$. When $\overline{\text{WEN}}$ is brought HIGH with $\overline{\text{LD}}$ and $\overline{\text{SEN}}$ restored to a LOW, the next offset bit in sequence is written to the registers via $\overline{\text{SI}}$. If an interruption of serial programming is desired, it is sufficient either to set $\overline{\text{LD}}$ LOW and deactivate $\overline{\text{SEN}}$ or to set $\overline{\text{SEN}}$ LOW and deactivate $\overline{\text{LD}}$. Once $\overline{\text{LD}}$ and $\overline{\text{SEN}}$ are both restored to a LOW level, serial offset programming continues.

From the time serial programming has begun, neither programmable flag will be valid until the full set of bits required to fill all the offset registers has been written. Measuring from the rising $\overline{\text{SCLK}}$ edge that achieves the above criteria; PAF will be valid after three more rising $\overline{\text{WCLK}}$ edges plus t_{PAF} , PAE will be valid after the next three rising $\overline{\text{RCLK}}$ edges plus t_{PAE} .

It is only possible to read the flag offset values via the parallel output port $\overline{\text{Qn}}$.

PARALLEL MODE

If Parallel Programming mode has been selected, as described above, then programming of PAE and PAF values can be achieved by using a combination of the $\overline{\text{LD}}$, $\overline{\text{WCLK}}$, $\overline{\text{WEN}}$ and $\overline{\text{Dn}}$ input pins. Programming PAE and PAF proceeds as follows: $\overline{\text{LD}}$ and $\overline{\text{WEN}}$ must be set LOW. For x72, x36 or x18 bit input bus widths, data on the inputs $\overline{\text{Dn}}$ are written into the Empty Offset Register on the first LOW-to-HIGH transition of $\overline{\text{WCLK}}$. Upon the second LOW-to-HIGH transition of $\overline{\text{WCLK}}$, data are written into the Full Offset Register. The third transition of $\overline{\text{WCLK}}$ writes, once again, to the Empty Offset Register. See Figure 3, *Programmable Flag Offset Programming Sequence*. See Figure 21, *Parallel Loading of Programmable Flag Registers*, for the timing diagram for this mode.

The act of writing offsets in parallel employs a dedicated write offset register pointer. The act of reading offsets employs a dedicated read offset register pointer. The two pointers operate independently; however, a read and a write should not be performed simultaneously to the offset registers. A Master Reset initializes both pointers to the Empty Offset register. A Partial Reset has no effect on the position of these pointers.

Write operations to the FIFO are allowed before and during the parallel programming sequence. In this case, the programming of all offset registers does not have to occur at one time. One offset register can be written and then by bringing $\overline{\text{LD}}$ HIGH, write operations can be redirected to the FIFO memory.

When $\overline{\text{LD}}$ is set LOW again, and $\overline{\text{WEN}}$ is LOW, the next offset register in sequence is written to. As an alternative to holding $\overline{\text{WEN}}$ LOW and toggling $\overline{\text{LD}}$, parallel programming can also be interrupted by setting $\overline{\text{LD}}$ LOW and toggling $\overline{\text{WEN}}$.

Note that the status of a programmable flag ($\overline{\text{PAE}}$ or $\overline{\text{PAF}}$) output is invalid during the programming process. From the time parallel programming has begun, a programmable flag output will not be valid until the appropriate offset word has been written to the register pertaining to that flag. Measuring from the rising $\overline{\text{WCLK}}$ edge that achieves the above criteria; PAF will be valid after two more rising $\overline{\text{WCLK}}$ edges plus t_{PAF} , PAE will be valid after the next two rising $\overline{\text{RCLK}}$ edges plus t_{PAE} plus t_{SKEW2} .

The act of reading the offset registers employs a dedicated read offset register pointer. The contents of the offset registers can be read on the $\overline{\text{Q0-Q16}}$ pins when $\overline{\text{LD}}$ is set LOW and $\overline{\text{REN}}$ is set LOW. For x72, x36 or x18 output bus width, data are read via $\overline{\text{Q0-Q16}}$ from the Empty Offset Register on the first LOW-to-HIGH transition of $\overline{\text{RCLK}}$. Upon the second LOW-to-HIGH transition of $\overline{\text{RCLK}}$, data are read from the Full Offset Register. The third transition of $\overline{\text{RCLK}}$ reads, once again, from the Empty Offset Register. See Figure 3, *Programmable Flag Offset Programming Sequence*. See Figure 22, *Parallel Read of Programmable Flag Registers*, for the timing diagram for this mode.

It is permissible to interrupt the offset register read sequence with reads or writes to the FIFO. The interruption is accomplished by deasserting $\overline{\text{REN}}$, $\overline{\text{LD}}$, or both together. When $\overline{\text{REN}}$ and $\overline{\text{LD}}$ are restored to a LOW level, reading of the offset registers continues where it left off. It should be noted, and care should be taken from the fact that when a parallel read of the flag offsets is performed, the data word that was present on the output lines $\overline{\text{Qn}}$ will be overwritten.

Parallel reading of the offset registers is always permitted regardless of which timing mode (IDT Standard or FWFT modes) has been selected.

RETRANSMIT OPERATION

The Retransmit operation allows data that has already been read to be accessed again. There are 2 modes of Retransmit operation, normal latency and zero latency. There are two stages to Retransmit: first, a setup procedure that resets the read pointer to the first location of memory, then the actual retransmit, which consists of reading out the memory contents, starting at the beginning of memory.

Retransmit setup is initiated by holding $\overline{\text{RT}}$ LOW during a rising $\overline{\text{RCLK}}$ edge. $\overline{\text{REN}}$ and $\overline{\text{WEN}}$ must be HIGH before bringing $\overline{\text{RT}}$ LOW. When zero latency is utilized, $\overline{\text{REN}}$ does not need to be HIGH before bringing $\overline{\text{RT}}$ LOW. At least two words, but no more than $D - 2$ words should have been written into the FIFO, and read from the FIFO, between Reset (Master or Partial) and the time of Retransmit setup. $D = 512$ for the IDT72V7230, 1,024 for the IDT72V7240, 2,048 for the IDT72V7250, 4,096 for the IDT72V7260, 8,192 for the IDT72V7270, 16,384 for the IDT72V7280, 32,768 for the IDT72V7290 and 65,536 for the IDT72V72100. In FWFT mode, $D = 513$ for the IDT72V7230, 1,025 for the IDT72V7240, 2,049 for the IDT72V7250, 4,097 for the IDT72V7260, 8,193 for the IDT72V7270, 16,385 for the IDT72V7280, 32,769 for the IDT72V7290 and 65,537 for the IDT72V72100.

If IDT Standard mode is selected, the FIFO will mark the beginning of the Retransmit setup by setting $\overline{\text{EF}}$ LOW. The change in level will only be noticeable if $\overline{\text{EF}}$ was HIGH before setup. During this period, the internal read pointer is initialized to the first location of the RAM array.

When $\overline{\text{EF}}$ goes HIGH, Retransmit setup is complete and read operations may begin starting with the first location in memory. Since IDT Standard mode is selected, every word read including the first word following Retransmit setup requires a LOW on $\overline{\text{REN}}$ to enable the rising edge of $\overline{\text{RCLK}}$. See Figure 16, *Retransmit Timing (IDT Standard Mode)*, for the relevant timing diagram.

If FWFT mode is selected, the FIFO will mark the beginning of the Retransmit setup by setting \overline{OR} HIGH. During this period, the internal read pointer is set to the first location of the RAM array.

When \overline{OR} goes LOW, Retransmit setup is complete; at the same time, the contents of the first location appear on the outputs. Since FWFT mode is selected, the first word appears on the outputs, no LOW on \overline{REN} is necessary. Reading all subsequent words requires a LOW on \overline{REN} to enable the rising edge of RCLK. See Figure 17, *Retransmit Timing (FWFT Mode)*, for the relevant timing diagram.

For either IDT Standard mode or FWFT mode, updating of the \overline{PAE} , \overline{HF} and \overline{PAF} flags begin with the rising edge of RCLK that \overline{RT} is setup. \overline{PAE} is

synchronized to RCLK, thus on the second rising edge of RCLK after \overline{RT} is setup, the \overline{PAE} flag will be updated. \overline{HF} is asynchronous, thus the rising edge of RCLK that \overline{RT} is setup will update \overline{HF} . \overline{PAF} is synchronized to WCLK, thus the second rising edge of WCLK that occurs t_{SKW} after the rising edge of RCLK that \overline{RT} is setup will update \overline{PAF} . \overline{RT} is synchronized to RCLK.

The Retransmit function has the option of two modes of operation, either "normal latency" or "zero latency". Figure 16 and Figure 17 mentioned previously, relate to "normal latency". Figure 18 and Figure 19 show "zero latency" retransmit operation. Zero latency basically means that the first data word to be retransmitted, is placed onto the output register with respect to the RCLK pulse that initiated the retransmit.

SIGNAL DESCRIPTION

INPUTS:

DATA IN (D₀ - D_n)

Data inputs for 72-bit wide data (D₀ - D₇₁), data inputs for 36-bit wide data (D₀ - D₃₅) or data inputs for 18-bit wide data (D₀ - D₁₇).

CONTROLS:

MASTER RESET ($\overline{\text{MRS}}$)

A Master Reset is accomplished whenever the $\overline{\text{MRS}}$ input is taken to a LOW state. This operation sets the internal read and write pointers to the first location of the RAM array. $\overline{\text{PAE}}$ will go LOW, $\overline{\text{PAF}}$ will go HIGH, and $\overline{\text{HF}}$ will go HIGH.

If FWFT/SI is LOW during Master Reset then the IDT Standard mode, along with $\overline{\text{EF}}$ and $\overline{\text{FF}}$ are selected. $\overline{\text{EF}}$ will go LOW and $\overline{\text{FF}}$ will go HIGH. If FWFT/SI is HIGH, then the First Word Fall Through mode (FWFT), along with $\overline{\text{IR}}$ and $\overline{\text{OR}}$, are selected. $\overline{\text{OR}}$ will go HIGH and $\overline{\text{IR}}$ will go LOW.

All control settings such as OW, IW, BM, $\overline{\text{BE}}$, RM, PFM and IP are defined during the Master Reset cycle.

During a Master Reset, the output register is initialized to all zeroes. A Master Reset is required after power up, before a write operation can take place. $\overline{\text{MRS}}$ is asynchronous.

See Figure 8, *Master Reset Timing*, for the relevant timing diagram.

PARTIAL RESET ($\overline{\text{PRS}}$)

A Partial Reset is accomplished whenever the PRS input is taken to a LOW state. As in the case of the Master Reset, the internal read and write pointers are set to the first location of the RAM array, PAE goes LOW, PAF goes HIGH, and HF goes HIGH.

Whichever mode is active at the time of Partial Reset, IDT Standard mode or First Word Fall Through, that mode will remain selected. If the IDT Standard mode is active, then $\overline{\text{FF}}$ will go HIGH and $\overline{\text{EF}}$ will go LOW. If the First Word Fall Through mode is active, then $\overline{\text{OR}}$ will go HIGH, and $\overline{\text{IR}}$ will go LOW.

Following Partial Reset, all values held in the offset registers remain unchanged. The programming method (parallel or serial) currently active at the time of Partial Reset is also retained. The output register is initialized to all zeroes. $\overline{\text{PRS}}$ is asynchronous.

A Partial Reset is useful for resetting the device during the course of operation, when reprogramming programmable flag offset settings may not be convenient.

See Figure 9, *Partial Reset Timing*, for the relevant timing diagram.

RETRANSMIT ($\overline{\text{RT}}$)

The Retransmit operation allows data that has already been read to be accessed again. There are 2 modes of Retransmit operation, normal latency and zero latency. There are two stages to Retransmit: first, a setup procedure that resets the read pointer to the first location of memory, then the actual retransmit, which consists of reading out the memory contents, starting at the beginning of the memory.

Retransmit setup is initiated by holding $\overline{\text{RT}}$ LOW during a rising RCLK edge. $\overline{\text{REN}}$ and $\overline{\text{WEN}}$ must be HIGH before bringing $\overline{\text{RT}}$ LOW. When zero latency is utilized, $\overline{\text{REN}}$ does not need to be HIGH before bringing $\overline{\text{RT}}$ LOW.

If IDT Standard mode is selected, the FIFO will mark the beginning of the Retransmit setup by setting $\overline{\text{EF}}$ LOW. The change in level will only be noticeable if $\overline{\text{EF}}$ was HIGH before setup. During this period, the internal read pointer is initialized to the first location of the RAM array.

When $\overline{\text{EF}}$ goes HIGH, Retransmit setup is complete and read operations may begin starting with the first location in memory. Since IDT Standard mode is selected, every word read including the first word following Retransmit setup requires a LOW on $\overline{\text{REN}}$ to enable the rising edge of RCLK. See Figure 16, *Retransmit Timing (IDT Standard Mode)*, for the relevant timing diagram.

If FWFT mode is selected, the FIFO will mark the beginning of the Retransmit setup by setting $\overline{\text{OR}}$ HIGH. During this period, the internal read pointer is set to the first location of the RAM array.

When $\overline{\text{OR}}$ goes LOW, Retransmit setup is complete; at the same time, the contents of the first location appear on the outputs. Since FWFT mode is selected, the first word appears on the outputs, no LOW on $\overline{\text{REN}}$ is necessary. Reading all subsequent words requires a LOW on $\overline{\text{REN}}$ to enable the rising edge of RCLK. See Figure 17, *Retransmit Timing (FWFT Mode)*, for the relevant timing diagram.

In Retransmit operation, zero latency mode can be selected using the Retransmit Mode (RM) pin during a Master Reset. This can be applied to both IDT Standard mode and FWFT mode.

Note, the Read Chip Select ($\overline{\text{RCS}}$) input must be LOW during Retransmit. The $\overline{\text{RCS}}$ input enables/disables the $\overline{\text{REN}}$ input.

FIRST WORD FALL THROUGH/SERIAL IN (FWFT/SI)

This is a dual purpose pin. During Master Reset, the state of the FWFT/SI input determines whether the device will operate in IDT Standard mode or First Word Fall Through (FWFT) mode.

If, at the time of Master Reset, FWFT/SI is LOW, then IDT Standard mode will be selected. This mode uses the Empty Flag ($\overline{\text{EF}}$) to indicate whether or not there are any words present in the FIFO memory. It also uses the Full Flag function ($\overline{\text{FF}}$) to indicate whether or not the FIFO memory has any free space for writing. In IDT Standard mode, every word read from the FIFO, including the first, must be requested using the Read Enable ($\overline{\text{REN}}$) and RCLK.

If, at the time of Master Reset, FWFT/SI is HIGH, then FWFT mode will be selected. This mode uses Output Ready ($\overline{\text{OR}}$) to indicate whether or not there is valid data at the data outputs (Q_n). It also uses Input Ready ($\overline{\text{IR}}$) to indicate whether or not the FIFO memory has any free space for writing. In the FWFT mode, the first word written to an empty FIFO goes directly to Q_n after three RCLK rising edges, $\overline{\text{REN}} = \text{LOW}$ is not necessary. Subsequent words must be accessed using the Read Enable ($\overline{\text{REN}}$) and RCLK.

After Master Reset, FWFT/SI acts as a serial input for loading $\overline{\text{PAE}}$ and $\overline{\text{PAF}}$ offsets into the programmable registers. The serial input function can only be used when the serial loading method has been selected during Master Reset. Serial programming using the FWFT/SI pin functions the same way in both IDT Standard and FWFT modes.

WRITE CLOCK (WCLK)

A write cycle is initiated on the rising edge of the WCLK input. Data setup and hold times must be met with respect to the LOW-to-HIGH transition of the WCLK. It is permissible to stop the WCLK. Note that while WCLK is idle, the $\overline{\text{FF}}$ / $\overline{\text{IR}}$, $\overline{\text{PAF}}$ and $\overline{\text{HF}}$ flags will not be updated. (Note that WCLK is only capable of updating $\overline{\text{HF}}$ flag to LOW.) The Write and Read Clocks can either be independent or coincident.

WRITE ENABLE ($\overline{\text{WEN}}$)

When the $\overline{\text{WEN}}$ input is LOW, data may be loaded into the FIFO RAM array on the rising edge of every WCLK cycle if the device is not full. Data is stored in the RAM array sequentially and independently of any ongoing read operation.

When \overline{WEN} is HIGH, no new data is written in the RAM array on each WCLK cycle.

To prevent data overflow in the IDT Standard mode, \overline{FF} will go LOW, inhibiting further write operations. Upon the completion of a valid read cycle, \overline{FF} will go HIGH allowing a write to occur. The \overline{FF} is updated by two WCLK cycles + t_{SKEW} after the RCLK cycle.

To prevent data overflow in the FWFT mode, \overline{IR} will go HIGH, inhibiting further write operations. Upon the completion of a valid read cycle, \overline{IR} will go LOW allowing a write to occur. The \overline{IR} flag is updated by two WCLK cycles + t_{SKEW} after the valid RCLK cycle.

\overline{WEN} is ignored when the FIFO is full in either FWFT or IDT Standard mode.

READ CLOCK (RCLK)

A read cycle is initiated on the rising edge of the RCLK input. Data can be read on the outputs, on the rising edge of the RCLK input. It is permissible to stop the RCLK. Note that while RCLK is idle, the $\overline{EF/OR}$, \overline{PAE} and \overline{HF} flags will not be updated. (Note that RCLK is only capable of updating the \overline{HF} flag to HIGH.) The Write and Read Clocks can be independent or coincident.

READ ENABLE (\overline{REN})

When Read Enable is LOW, data is loaded from the RAM array into the output register on the rising edge of every RCLK cycle if the device is not empty.

When the \overline{REN} input is HIGH, the output register holds the previous data and no new data is loaded into the output register. The data outputs Q_0 - Q_n maintain the previous data value.

In the IDT Standard mode, every word accessed at Q_n , including the first word written to an empty FIFO, must be requested using \overline{REN} provided that \overline{RCS} is LOW. When the last word has been read from the FIFO, the Empty Flag (\overline{EF}) will go LOW, inhibiting further read operations. \overline{REN} is ignored when the FIFO is empty. Once a write is performed, \overline{EF} will go HIGH allowing a read to occur. The \overline{EF} flag is updated by two RCLK cycles + t_{SKEW} after the valid WCLK cycle.

In the FWFT mode, the first word written to an empty FIFO automatically goes to the outputs Q_n , on the third valid LOW-to-HIGH transition of RCLK + t_{SKEW} after the first write. \overline{REN} and \overline{RCS} do not need to be asserted LOW. In order to access all other words, a read must be executed using \overline{REN} and \overline{RCS} must be enabled LOW. The RCLK LOW-to-HIGH transition after the last word has been read from the FIFO, Output Ready (\overline{OR}) will go HIGH with a true read (RCLK with \overline{REN} = LOW; \overline{RCS} = LOW), inhibiting further read operations. \overline{REN} is ignored when the FIFO is empty.

SERIAL CLOCK (SCLK)

During serial loading of the programmable flag offset registers, a rising edge on the SCLK input is used to load serial data present on the SI input provided that the \overline{SEN} input is LOW.

SERIAL ENABLE (\overline{SEN})

The \overline{SEN} input is an enable used only for serial programming of the offset registers. The serial programming method must be selected during Master Reset. \overline{SEN} is always used in conjunction with \overline{LD} . When these lines are both LOW, data at the SI input can be loaded into the program register one bit for each LOW-to-HIGH transition of SCLK.

When \overline{SEN} is HIGH, the programmable registers retains the previous settings and no offsets are loaded. \overline{SEN} functions the same way in both IDT Standard and FWFT modes.

OUTPUT ENABLE (\overline{OE})

When Output Enable is enabled (LOW), the parallel output buffers receive data from the output register. When \overline{OE} is HIGH, the output data bus (Q_n) goes

into a high impedance state. The \overline{OE} input is Asynchronous and should be enabled (held LOW) when using the \overline{RCS} input.

READ CHIP SELECT (\overline{RCS})

The Read Chip Select input provides synchronous control of the Read output port. When \overline{RCS} goes LOW, the next rising edge of RCLK causes the Q_n outputs to go to the LOW Z state. When \overline{RCS} goes HIGH, the next RCLK rising edge causes the Q_n outputs to return to HIGH Z.

During the time while \overline{RCS} is HIGH (disabled) all read operations are ignored. That is, the \overline{REN} input is disabled and data is not clocked from the RAM array to the output register.

The \overline{RCS} input does not effect the operation of the flags. For example, when the first word is written to an empty FIFO, the \overline{EF} will still go from LOW to HIGH based on a rising edge of RCLK, regardless of the state of the \overline{RCS} input.

Also, when operating the FIFO in FWFT mode the first word written to an empty FIFO will still be clocked through to the output register based on RCLK, regardless of the state of \overline{RCS} . The \overline{RCS} pin must also be active (LOW) in order to perform a Retransmit. See figure 12 for *Read Cycle and Read Chip Select Timing (IDT Standard Mode)*. See figure 15 for *Read Cycle and Read Chip Select Timing (First Word Fall Through Mode)*.

LOAD (\overline{LD})

This is a dual purpose pin. During Master Reset, the state of the \overline{LD} input, along with $FSEL_0$ and $FSEL_1$, determines one of eight default offset values for the \overline{PAE} and \overline{PAF} flags, along with the method by which these offset registers can be programmed, parallel or serial (see Table 2). After Master Reset, \overline{LD} enables write operations to and read operations from the offset registers. Only the offset loading method currently selected can be used to write to the registers. Offset registers can be read only in parallel.

After Master Reset, the \overline{LD} pin is used to activate the programming process of the flag offset values \overline{PAE} and \overline{PAF} . Pulling \overline{LD} LOW will begin a serial loading or parallel load or read of these offset values.

BUS-MATCHING (BM, IW, OW)

The pins BM, IW and OW are used to define the input and output bus widths. During Master Reset, the state of these pins is used to configure the device bus sizes. See Table 1 for control settings. All flags will operate on the word/byte size boundary as defined by the selection of bus width. See Figure 4 for *Bus-Matching Byte Arrangement*.

BIG-ENDIAN/LITTLE-ENDIAN (\overline{BE})

During Master Reset, a LOW on \overline{BE} will select Big-Endian operation. A HIGH on \overline{BE} during Master Reset will select Little-Endian format. This function is useful when the following input to output bus widths are implemented: x72 to x36, x72 to x18, x36 to x72 and x18 to x72. If Big-Endian mode is selected, then the most significant byte (word) of the long word written into the FIFO will be read out of the FIFO first, followed by the least significant long word. If Little-Endian format is selected, then the least significant word of the long word written into the FIFO will be read out first, followed by the most significant word. The mode desired is configured during master reset by the state of the Big-Endian (\overline{BE}) pin. See Figure 4 for *Bus-Matching Byte Arrangement*.

PROGRAMMABLE FLAG MODE (PFM)

During Master Reset, a LOW on PFM will select Asynchronous Programmable flag timing mode. A HIGH on PFM will select Synchronous Programmable flag timing mode. If asynchronous $\overline{PAF}/\overline{PAE}$ configuration is selected (PFM, LOW during MRS), the \overline{PAE} is asserted LOW on the LOW-to-HIGH transition of RCLK. \overline{PAE} is reset to HIGH on the LOW-to-HIGH transition of WCLK.

Similarly, the $\overline{\text{PAF}}$ is asserted LOW on the LOW-to-HIGH transition of WCLK and $\overline{\text{PAF}}$ is reset to HIGH on the LOW-to-HIGH transition of RCLK.

If synchronous $\overline{\text{PAE}}/\overline{\text{PAF}}$ configuration is selected (PFM, HIGH during MRS), the $\overline{\text{PAE}}$ is asserted and updated on the rising edge of RCLK only and not WCLK. Similarly, $\overline{\text{PAF}}$ is asserted and updated on the rising edge of WCLK only and not RCLK. The mode desired is configured during master reset by the state of the Programmable Flag Mode (PFM) pin.

INTERSPERSED PARITY (IP)

During Master Reset, a LOW on IP will select Non-Interspersed Parity mode. A HIGH will select Interspersed Parity mode. The IP bit function allows the user to select the parity bit in the long word loaded into the parallel port (Do-Dn) when programming the flag offsets. If Interspersed Parity mode is selected, then the FIFO will assume that the parity bits are located in bit position D8, D17, D26, D35, D44, D53, D62 and D71 during the parallel programming of the flag offsets. If Non-Interspersed Parity mode is selected, then D8, D17 and D28 are assumed to be valid bits and D64, D65, D66, D67, D68, D69, D70 and D71 are ignored. IP mode is selected during Master Reset by the state of the IP input pin.

OUTPUTS:

FULL FLAG ($\overline{\text{FF}}/\overline{\text{IR}}$)

This is a dual purpose pin. In IDT Standard mode, the Full Flag ($\overline{\text{FF}}$) function is selected. When the FIFO is full, $\overline{\text{FF}}$ will go LOW, inhibiting further write operations. When $\overline{\text{FF}}$ is HIGH, the FIFO is not full. If no reads are performed after a reset (either $\overline{\text{MRS}}$ or $\overline{\text{PRS}}$), $\overline{\text{FF}}$ will go LOW after D writes to the FIFO (D = 512 for the IDT72V7230, 1,024 for the IDT72V7240, 2,048 for the IDT72V7250, 4,096 for the IDT72V7260, 8,192 for the IDT72V7270, 16,384 for the IDT72V7280, 32,768 for the IDT72V7290 and 65,536 for the IDT72V72100). See Figure 10, *Write Cycle and Full Flag Timing (IDT Standard Mode)*, for the relevant timing information.

In FWFT mode, the Input Ready ($\overline{\text{IR}}$) function is selected. $\overline{\text{IR}}$ goes LOW when memory space is available for writing in data. When there is no longer any free space left, $\overline{\text{IR}}$ goes HIGH, inhibiting further write operations. If no reads are performed after a reset (either $\overline{\text{MRS}}$ or $\overline{\text{PRS}}$), $\overline{\text{IR}}$ will go HIGH after D writes to the FIFO (D = 513 for the IDT72V7230, 1,025 for the IDT72V7240, 2,049 for the IDT72V7250, 4,097 for the IDT72V7260, 8,193 for the IDT72V7270, 16,385 for the IDT72V7280, 32,769 for the IDT72V7290 and 65,537 for the IDT72V72100). See Figure 13, *Write Timing (FWFT Mode)*, for the relevant timing information.

The $\overline{\text{IR}}$ status not only measures the contents of the FIFO memory, but also counts the presence of a word in the output register. Thus, in FWFT mode, the total number of writes necessary to deassert $\overline{\text{IR}}$ is one greater than needed to assert $\overline{\text{FF}}$ in IDT Standard mode.

$\overline{\text{FF}}/\overline{\text{IR}}$ is synchronous and updated on the rising edge of WCLK. $\overline{\text{FF}}/\overline{\text{IR}}$ are double register-buffered outputs.

EMPTY FLAG ($\overline{\text{EF}}/\overline{\text{OR}}$)

This is a dual purpose pin. In the IDT Standard mode, the Empty Flag ($\overline{\text{EF}}$) function is selected. When the FIFO is empty, $\overline{\text{EF}}$ will go LOW, inhibiting further read operations. When $\overline{\text{EF}}$ is HIGH, the FIFO is not empty. See Figure 11, *Read Cycle, Output Enable, Empty Flag and First Word Latency Timing (IDT Standard Mode)*, for the relevant timing information.

In FWFT mode, the Output Ready ($\overline{\text{OR}}$) function is selected. $\overline{\text{OR}}$ goes LOW at the same time that the first word written to an empty FIFO appears valid on the outputs. $\overline{\text{OR}}$ stays LOW after the RCLK LOW to HIGH transition that shifts the last word from the FIFO memory to the outputs. $\overline{\text{OR}}$ goes HIGH only with a true read (RCLK with $\overline{\text{REN}} = \text{LOW}$). The previous data stays at the outputs,

indicating the last word was read. Further data reads are inhibited until $\overline{\text{OR}}$ goes LOW again. See Figure 10, *Read Timing (FWFT Mode)*, for the relevant timing information.

$\overline{\text{EF}}/\overline{\text{OR}}$ is synchronous and updated on the rising edge of RCLK.

In IDT Standard mode, $\overline{\text{EF}}$ is a double register-buffered output. In FWFT mode, $\overline{\text{OR}}$ is a triple register-buffered output.

PROGRAMMABLE ALMOST-FULL FLAG ($\overline{\text{PAF}}$)

The Programmable Almost-Full flag ($\overline{\text{PAF}}$) will go LOW when the FIFO reaches the almost-full condition. In IDT Standard mode, if no reads are performed after reset ($\overline{\text{MRS}}$), $\overline{\text{PAF}}$ will go LOW after (D - m) words are written to the FIFO. The $\overline{\text{PAF}}$ will go LOW after (512-m) writes for the IDT72V7230, (1,024-m) writes for the IDT72V7240, (2,048-m) writes for the IDT72V7250, (4,096-m) writes for the IDT72V7260, (8,192-m) writes for the IDT72V7270, (16,384-m) writes for the IDT72V7280, (32,768-m) writes for the IDT72V7290, and (65,536-m) writes for the IDT72V72100. The offset "m" is the full offset value. The default setting for this value is stated in the footnote of Table 1.

In FWFT mode, the $\overline{\text{PAF}}$ will go LOW after (513-m) writes for the IDT72V7230, (1,025-m) writes for the IDT72V7240, (2,049-m) writes for the IDT72V7250, (4,097-m) writes for the IDT72V7260 and (8,193-m) writes for the IDT72V7270, (16,385-m) writes for the IDT72V7280, (32,769-m) writes for the IDT72V7290 and (65,537-m) writes for the IDT72V72100, where "m" is the full offset value. The default setting for this value is stated in Table 2.

See Figure 23, *Synchronous Programmable Almost-Full Flag Timing (IDT Standard and FWFT Modes)*, for the relevant timing information.

If asynchronous $\overline{\text{PAF}}$ configuration is selected, the $\overline{\text{PAF}}$ is asserted LOW on the LOW-to-HIGH transition of the Write Clock (WCLK). $\overline{\text{PAF}}$ is reset to HIGH on the LOW-to-HIGH transition of the Read Clock (RCLK). If synchronous $\overline{\text{PAF}}$ configuration is selected, the $\overline{\text{PAF}}$ is updated on the rising edge of WCLK. See Figure 25, *Asynchronous Almost-Full Flag Timing (IDT Standard and FWFT Modes)*.

PROGRAMMABLE ALMOST-EMPTY FLAG ($\overline{\text{PAE}}$)

The Programmable Almost-Empty flag ($\overline{\text{PAE}}$) will go LOW when the FIFO reaches the almost-empty condition. In IDT Standard mode, $\overline{\text{PAE}}$ will go LOW when there are n words or less in the FIFO. The offset "n" is the empty offset value. The default setting for this value is stated in the footnote of Table 1.

In FWFT mode, the $\overline{\text{PAE}}$ will go LOW when there are n+1 words or less in the FIFO. The default setting for this value is stated in Table 2.

See Figure 24, *Synchronous Programmable Almost-Empty Flag Timing (IDT Standard and FWFT Modes)*, for the relevant timing information.

If asynchronous $\overline{\text{PAE}}$ configuration is selected, the $\overline{\text{PAE}}$ is asserted LOW on the LOW-to-HIGH transition of the Read Clock (RCLK). $\overline{\text{PAE}}$ is reset to HIGH on the LOW-to-HIGH transition of the Write Clock (WCLK). If synchronous $\overline{\text{PAE}}$ configuration is selected, the $\overline{\text{PAE}}$ is updated on the rising edge of RCLK. See Figure 26, *Asynchronous Programmable Almost-Empty Flag Timing (IDT Standard and FWFT Modes)*.

HALF-FULL FLAG ($\overline{\text{HF}}$)

This output indicates a half-full FIFO. The rising WCLK edge that fills the FIFO beyond half-full sets $\overline{\text{HF}}$ LOW. The flag remains LOW until the difference between the write and read pointers becomes less than or equal to half of the total depth of the device; the rising RCLK edge that accomplishes this condition sets $\overline{\text{HF}}$ HIGH.

In IDT Standard mode, if no reads are performed after reset ($\overline{\text{MRS}}$ or $\overline{\text{PRS}}$), $\overline{\text{HF}}$ will go LOW after (D/2 + 1) writes to the FIFO, where D = 512 for the IDT72V7230, 1,024 for the IDT72V7240, 2,048 for the IDT72V7250, 4,096 for

the IDT72V7260, 8,192 for the IDT72V7270, 16,384 for the IDT72V7280, 32,768 for the IDT72V7290 and 65,536 for the IDT72V72100.

In FWFT mode, if no reads are performed after reset ($\overline{\text{MRS}}$ or $\overline{\text{PRS}}$), $\overline{\text{HF}}$ will go LOW after $(D-1/2 + 2)$ writes to the FIFO, where $D = 513$ for the IDT72V7230, 1,025 for the IDT72V7240, 2,049 for the IDT72V7250, 4,097 for the IDT72V7260, 8,193 for the IDT72V7270, 16,385 for the IDT72V7280, 32,769 for the IDT72V7290 and 65,537 for the IDT72V72100.

See Figure 27, *Half-Full Flag Timing (IDT Standard and FWFT Modes)*, for the relevant timing information. Because $\overline{\text{HF}}$ is updated by both RCLK and WCLK, it is considered asynchronous.

DATA OUTPUTS (Q0-Qn)

(Q0-Q71) are data outputs for 72-bit wide data, (Q0-Q35) are data outputs for 36-bit wide data or (Q0-Q17) are data outputs for 18-bit wide data.

BYTE ORDER ON INPUT PORT:

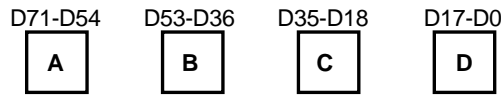

Write to FIFO

BYTE ORDER ON OUTPUT PORT:

\overline{BE}	BM	IW	OW
X	L	X	X

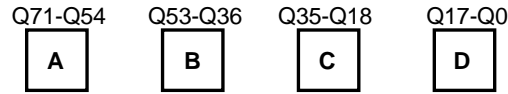

Read from FIFO

(a) x72 INPUT to x72 OUTPUT

\overline{BE}	BM	IW	OW
L	H	L	L

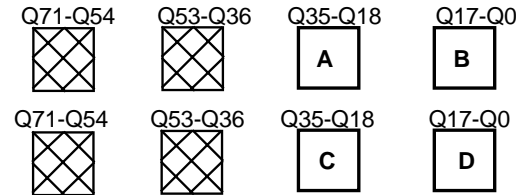

1st: Read from FIFO

2nd: Read from FIFO

(b) x72 INPUT to x36 OUTPUT - BIG-ENDIAN

\overline{BE}	BM	IW	OW
H	H	L	L

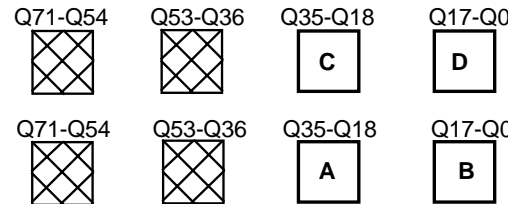

1st: Read from FIFO

2nd: Read from FIFO

(c) x72 INPUT to x36 OUTPUT - LITTLE-ENDIAN

\overline{BE}	BM	IW	OW
L	H	L	H

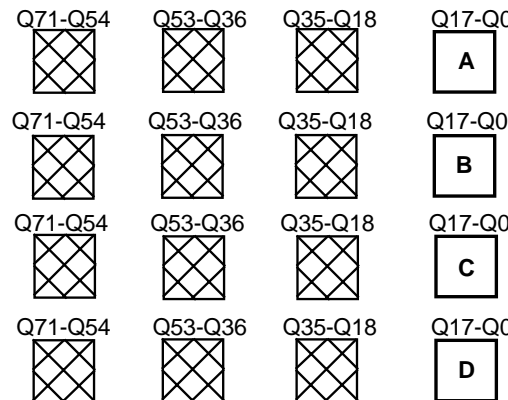

1st: Read from FIFO

2nd: Read from FIFO

3rd: Read from FIFO

4th: Read from FIFO

(d) x72 INPUT to x18 OUTPUT - BIG-ENDIAN

\overline{BE}	BM	IW	OW
H	H	L	H

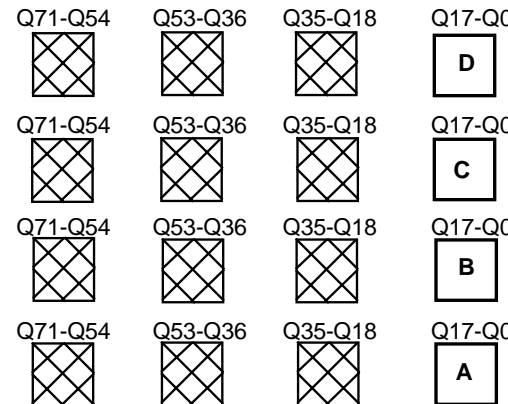

1st: Read from FIFO

2nd: Read from FIFO

3rd: Read from FIFO

4th: Read from FIFO

(e) x72 INPUT to x18 OUTPUT - LITTLE-ENDIAN

4680 drw08

Figure 4. Bus-Matching Byte Arrangement

BYTE ORDER ON INPUT PORT:

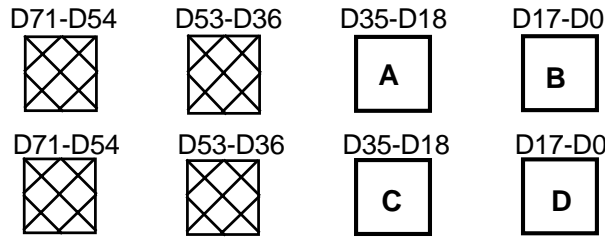

1st: Write to FIFO

2nd: Write to FIFO

BYTE ORDER ON OUTPUT PORT:

\overline{BE}	BM	IW	OW
L	H	H	L

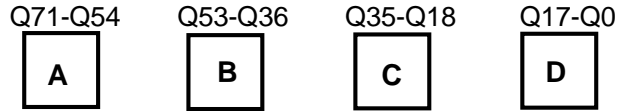

Read from FIFO

(a) x36 INPUT to x72 OUTPUT - BIG-ENDIAN

\overline{BE}	BM	IW	OW
H	H	H	L

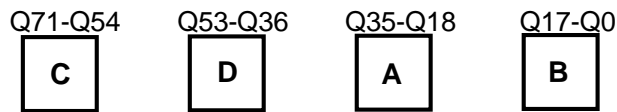

Read from FIFO

(b) x36 INPUT to x72 OUTPUT - LITTLE-ENDIAN

BYTE ORDER ON INPUT PORT:

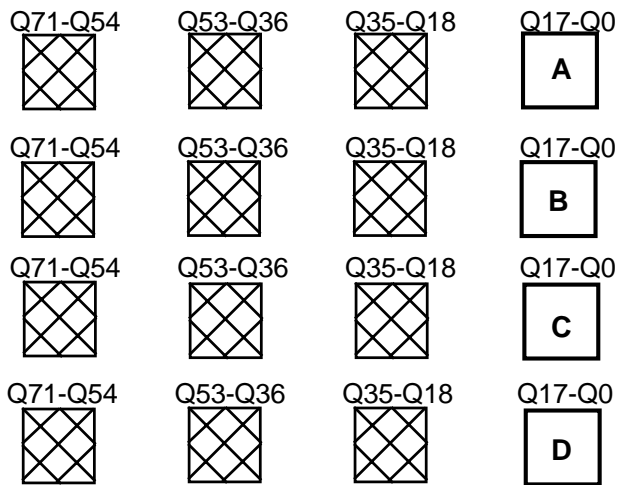

1st: Write to FIFO

2nd: Write to FIFO

3rd: Write to FIFO

4th: Write to FIFO

BYTE ORDER ON OUTPUT PORT:

\overline{BE}	BM	IW	OW
L	H	H	H

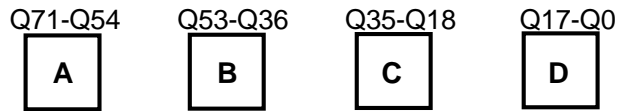

Read from FIFO

(a) x18 INPUT to x72 OUTPUT - BIG-ENDIAN

\overline{BE}	BM	IW	OW
H	H	H	H

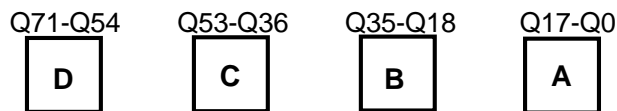

Read from FIFO

(b) x18 INPUT to x72 OUTPUT - LITTLE-ENDIAN

4680 drw09

Figure 4. Bus-Matching Byte Arrangement (Continued)

JTAG TIMING SPECIFICATION

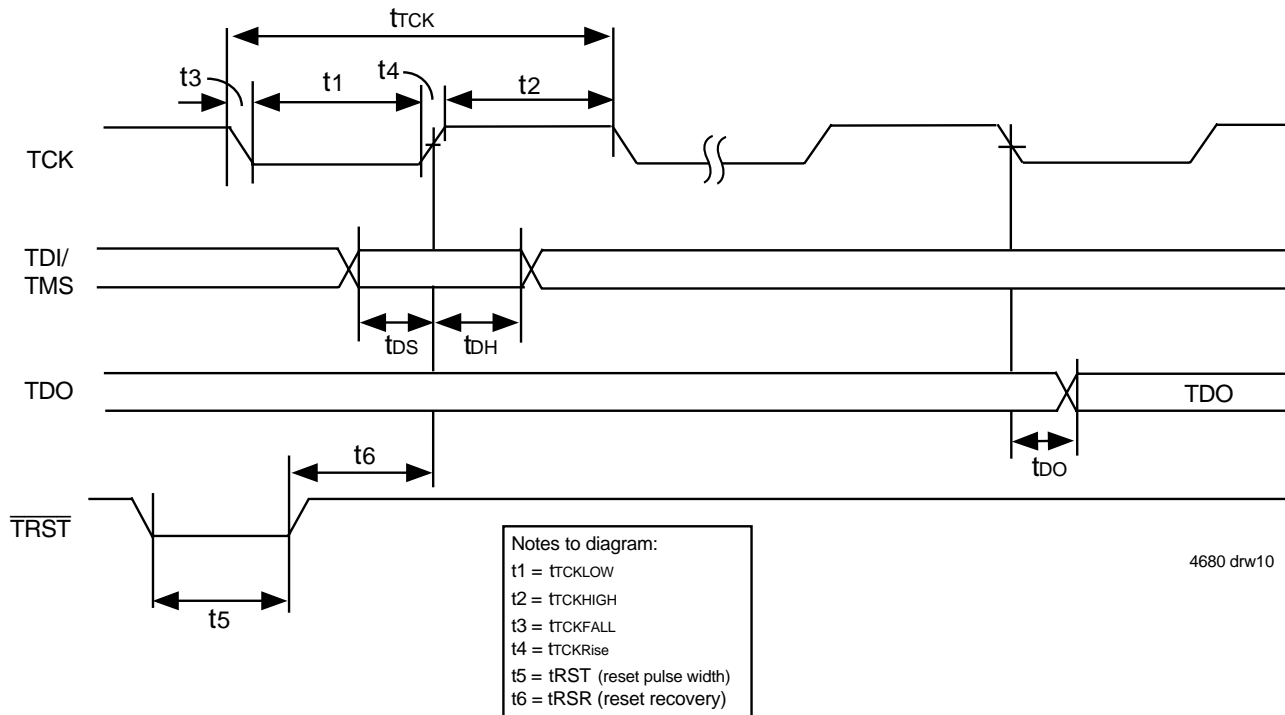

Figure 5. Standard JTAG Timing

SYSTEM INTERFACE PARAMETERS

Parameter	Symbol	Test Conditions	IDT72V7230 IDT72V7240 IDT72V7250 IDT72V7260 IDT72V7270 IDT72V7280 IDT72V7290 IDT72V72100		
			Min.	Max.	Units
Data Output	tDO = Max		5 ⁽¹⁾	50	ns
Data Output Hold	tDOH ²		5	-	ns
Data Input	tDS	t _{rise} =3ns	30	-	ns
	tDH	t _{fall} =3ns	30	-	ns

NOTES:

1. Guaranteed by design.
2. 50pf loading on external output signals.

JTAG AC ELECTRICAL CHARACTERISTICS

(Vcc = 3.3V ± 5%; Tcase = 0°C to +85°C)

Parameter	Symbol	Test Conditions			
			Min.	Max.	Units
JTAG Clock Input Period	tTCK	-	100	-	ns
JTAG Clock HIGH	tTCKHIGH	-	40	-	ns
JTAG Clock Low	tTCKLOW	-	40	-	ns
JTAG Clock Rise Time	tTCKRise	-	-	5 ⁽¹⁾	ns
JTAG Clock Fall Time	tTCKFall	-	-	5 ⁽¹⁾	ns
JTAG Reset	tRST	-	50	-	ns
JTAG Reset Recovery	tRSR	-	50	-	ns

NOTE:

1. Guaranteed by design.

JTAG Interface

Five additional pins (TDI, TDO, TMS, TCK and $\overline{\text{TRST}}$) are provided to support the JTAG boundary scan interface. The IDT72V7230/72V7240/72V7250/72V7260/72V7270/72V7280/72V7290/72V72100 incorporates the necessary tap controller and modified pad cells to implement the JTAG facility.

The JTAG boundary scan should only be used when the IDT72V7230/72V7240/72V7250/72V7260/72V7270/72V7280/72V7290/72V72100 is in the reset mode.

Note that IDT provides appropriate Boundary Scan Description Language program files for these devices.

Standard JTAG interface is used for Boundary Scan purposes while the IDT72V7230/72V7240/72V7250/72V7260/72V7270/72V7280/72V7290/72V72100 is held in the reset mode.

The Standard JTAG interface consists of four basic elements:

- Test Access Port (TAP)
- TAP controller
- Instruction Register (IR)
- Data Register Port (DR)

The following sections provide a brief description of each element. For a complete description refer to the IEEE Standard Test Access Port Specification (IEEE Std. 1149.1-1990).

The figure below shows the standard Boundary-Scan Architecture

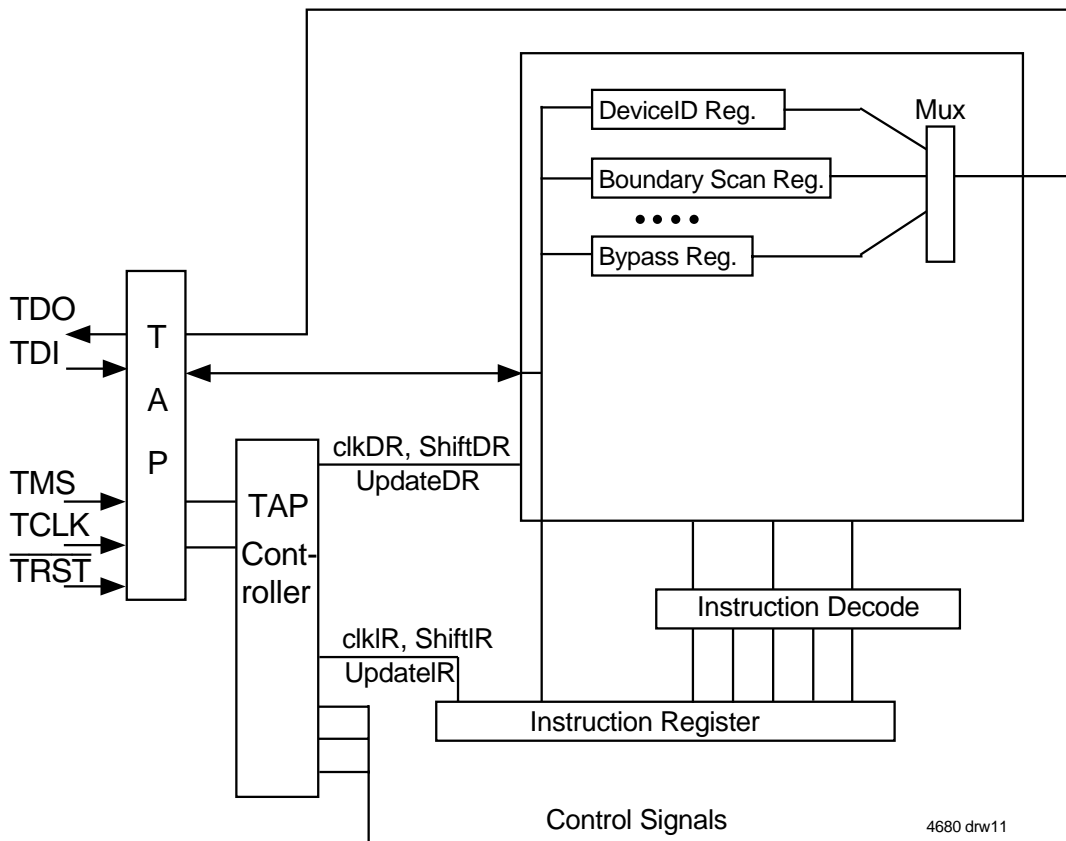

Figure 6. Boundary Scan Architecture

TEST ACCESS PORT (TAP)

The Tap interface is a general-purpose port that provides access to the internal of the processor. It consists of four input ports (TCLK, TMS, TDI, $\overline{\text{TRST}}$) and one output port (TDO).

THE TAP CONTROLLER

The Tap controller is a synchronous finite state machine that responds to TMS and TCLK signals to generate clock and control signals to the Instruction and Data Registers for capture and update of data.

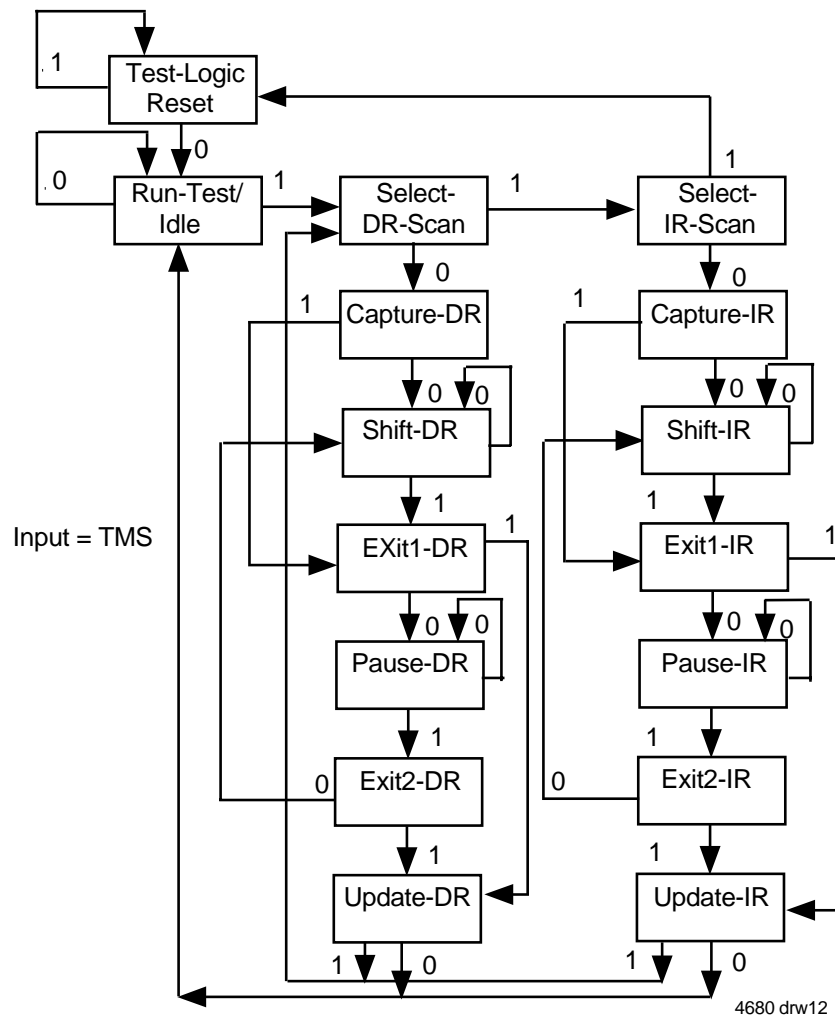

Figure 7. TAP Controller State Diagram

Refer to the IEEE Standard Test Access Port Specification (IEEE Std. 1149.1) for the full state diagram

All state transitions within the TAP controller occur at the rising edge of the TCLK pulse. The TMS signal level (0 or 1) determines the state progression that occurs on each TCLK rising edge.

CAPTURE-DR

Data is loaded from the parallel input pins or core outputs into the Data Register.

SHIFT-DR

The previously captured data is shifted in serially, LSB first at the rising edge of TCLK in the TDI/TDO path and shifted out serially, LSB first at the falling edge of TCLK towards the output.

UPDATE-DR

The shifting process has been completed. The data is latched into their parallel outputs in this state to be accessed through the internal bus.

EXIT1-DR / EXIT2-DR

This is a temporary controller state. If TMS is held high, a rising edge applied to TCLK while in this state causes the controller to enter the Update-DR state. This terminates the scanning process. All test data registers selected by the current instruction retain their previous state unchanged.

PAUSE-DR

This controller state allows shifting of the test data register in the serial path between TDI and TDO to be temporarily halted. All test data registers selected by the current instruction retain their previous state unchanged.

Capture-IR, Shift-IR and Update-IR, Exit-IR and Pause-IR are similar to Data registers. These instructions operate on the instruction registers.

THE INSTRUCTION REGISTER

The Instruction register allows an instruction to be shifted in serially into the processor at the rising edge of TCLK.

The Instruction is used to select the test to be performed, or the test data register to be accessed, or both. The instruction shifted into the register is latched at the completion of the shifting process when the TAP controller is at Update-IR state.

The instruction register must contain 4 bit instruction register-based cells which can hold instruction data. These mandatory cells are located nearest the serial outputs they are the least significant bits.

TEST DATA REGISTER

The Test Data register contains three test data registers: the Bypass, the Boundary Scan register and Device ID register.

These registers are connected in parallel between a common serial input and a common serial data output.

The following sections provide a brief description of each element. For a complete description, refer to the IEEE Standard Test Access Port Specification (IEEE Std. 1149.1-1990).

TEST BYPASS REGISTER

The register is used to allow test data to flow through the device from TDI to TDO. It contains a single stage shift register for a minimum length in serial path. When the bypass register is selected by an instruction, the shift register stage is set to a logic zero on the rising edge of TCLK when the TAP controller is in the Capture-DR state.

The operation of the bypass register should not have any effect on the operation of the device in response to the BYPASS instruction.

THE BOUNDARY-SCAN REGISTER

The Boundary Scan Register allows serial data TDI be loaded in to or read out of the processor input/output ports. The Boundary Scan Register is a part of the IEEE 1149.1-1990 Standard JTAG Implementation.

THE DEVICE IDENTIFICATION REGISTER

The Device Identification Register is a Read Only 32-bit register used to specify the manufacturer, part number and version of the processor to be determined through the TAP in response to the IDCODE instruction.

IDT JEDEC ID number is 0xB3. This translates to 0x33 when the parity is dropped in the 11-bit Manufacturer ID field.

For the IDT72V7230/72V7240/72V7250/72V7260/72V7270/72V7280/72V7290/72V72100, the Part Number field contains the following values:

Device	Part# Field
IDT72V7230	0x57
IDT72V7240	0x51
IDT72V7250	0x52
IDT72V7260	0x53
IDT72V7270	0x54
IDT72V7280	0x55
IDT72V7290	0x56
IDT72V72100	0x50

31(MSB)	28 27	12 11	1 0(LSB)
Version (4 bits)	Part Number (16-bit)	Manufacturer ID (11-bit)	
0X0		0X33	1

**IDT72V7230/40/50/60/70/80/90/100
JTAG DEVICE IDENTIFICATION REGISTER**

JTAG INSTRUCTION REGISTER

The Instruction register allows instruction to be serially input into the device when the TAP controller is in the Shift-IR state. The instruction is decoded to perform the following:

- Select test data registers that may operate while the instruction is current. The other test data registers should not interfere with chip operation and the selected data register.
- Define the serial test data register path that is used to shift data between TDI and TDO during data register scanning.

The Instruction Register is a 4 bit field (i.e. IR3, IR2, IR1, IR0) to decode 16 different possible instructions. Instructions are decoded as follows.

Hex Value	Instruction	Function
0x00	EXTEST	Select Boundary Scan Register
0x02	IDCODE	Select Chip Identification data register
0x01	SAMPLE/PRELOAD	Select Boundary Scan Register
0x03	HI-Z	JTAG
0x0F	BYPASS	Select Bypass Register

JTAG INSTRUCTION REGISTER DECODING

The following sections provide a brief description of each instruction. For a complete description refer to the IEEE Standard Test Access Port Specification (IEEE Std. 1149.1-1990).

EXTEST

The mandatory EXTEST instruction is provided for external circuitry and board level interconnection check.

IDCODE

This instruction is provided to select Device Identification Register to read out manufacture's identity, part number and version number.

SAMPLE/PRELOAD

The mandatory SAMPLE/PRELOAD instruction allows data values to be loaded onto the latched parallel outputs of the boundary-scan shift register prior to selection of the boundary-scan test instruction. The SAMPLE instruction allows a snapshot of data flowing from the system pins to the on-chip logic or vice versa.

HIGH Z

This instruction places all the output pins on the device into a high impedance state.

BYPASS

The Bypass instruction contains a single shift-register stage and is set to provide a minimum-length serial path between the TDI and the TDO pins of the device when no test operation of the device is required.

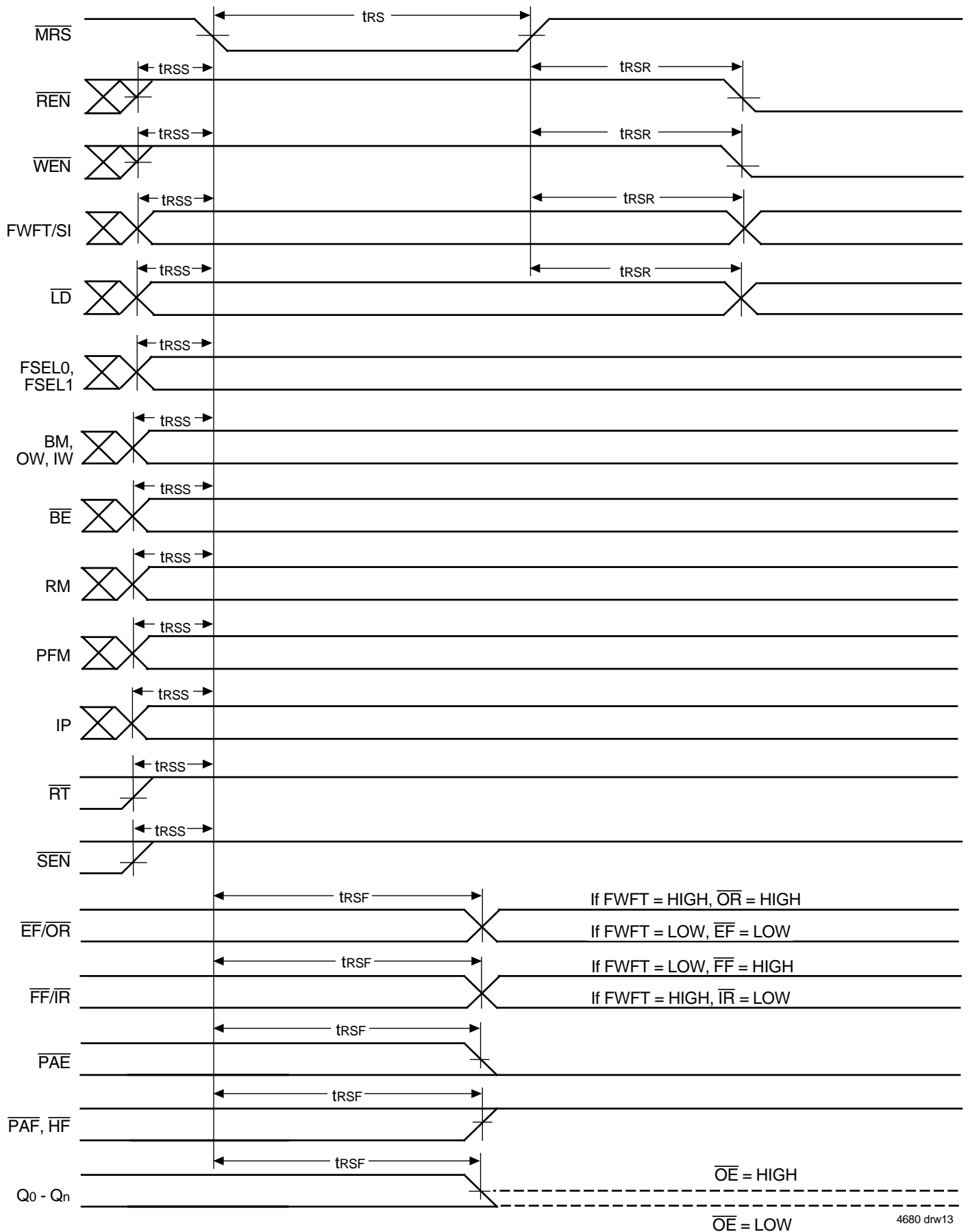

4680 drw13

Figure 8. Master Reset Timing

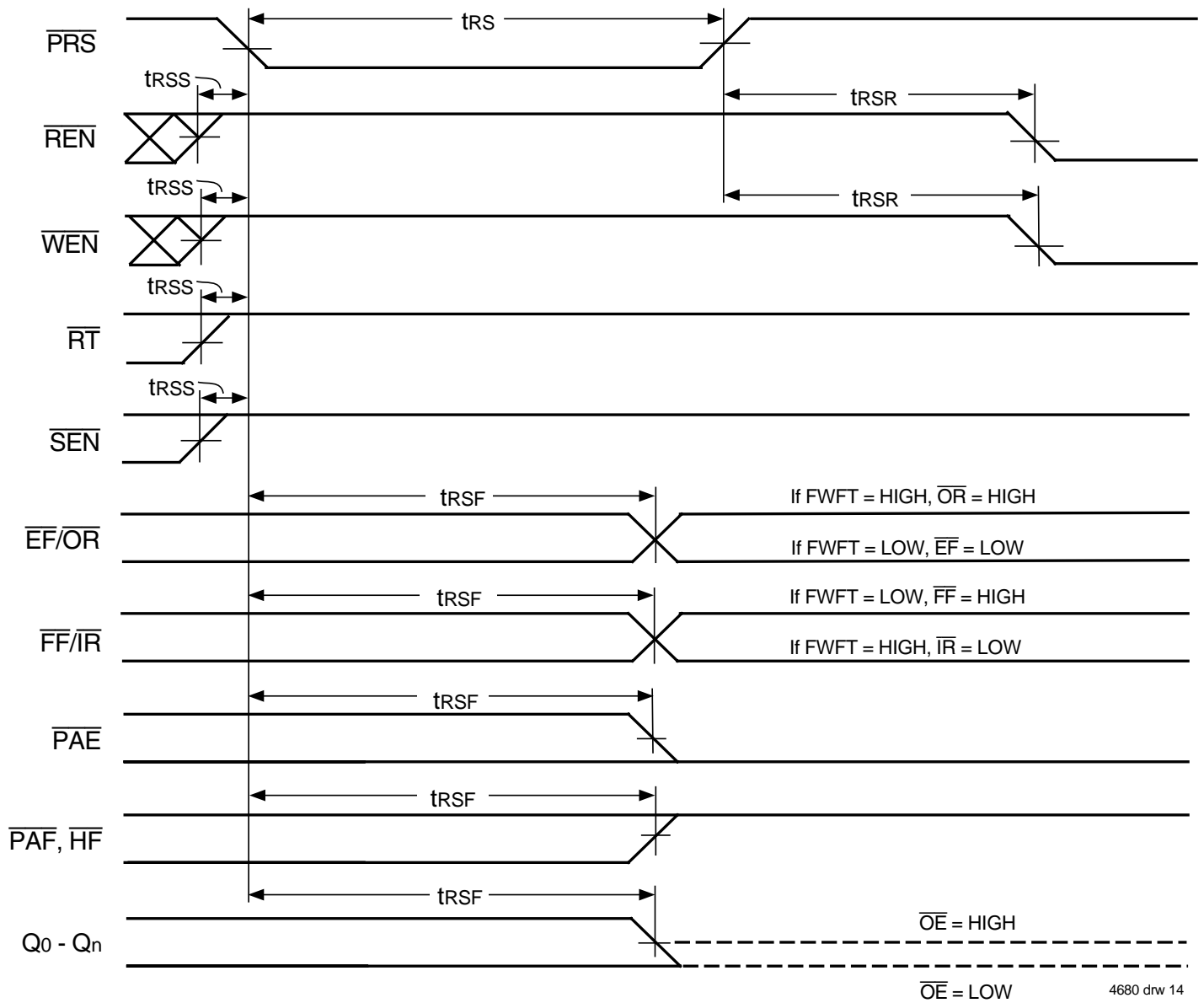

4680 drw 14

Figure 9. Partial Reset Timing

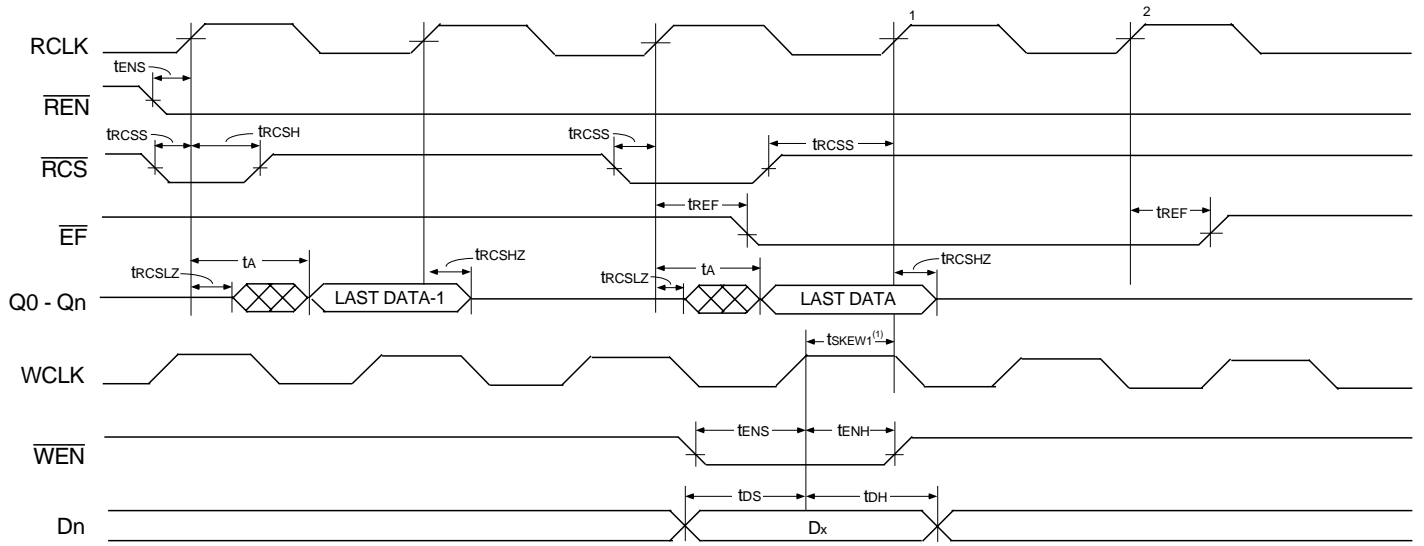

4680 drw 17

NOTES:

1. t_{SKEW1} is the minimum time between a rising WCLK edge and a rising RCLK edge to guarantee that \overline{EF} will go HIGH (after one RCLK cycle plus t_{REF}). If the time between the rising edge of WCLK and the rising edge of RCLK is less than t_{SKEW1} , then \overline{EF} deassertion may be delayed one extra RCLK cycle.
2. \overline{LD} = HIGH.
3. First data word latency = $t_{SKEW1} + 1 \cdot T_{RCLK} + t_{REF}$.
4. \overline{OE} is LOW.

Figure 12. Read Cycle and Read Chip Select Timing (IDT Standard Mode)

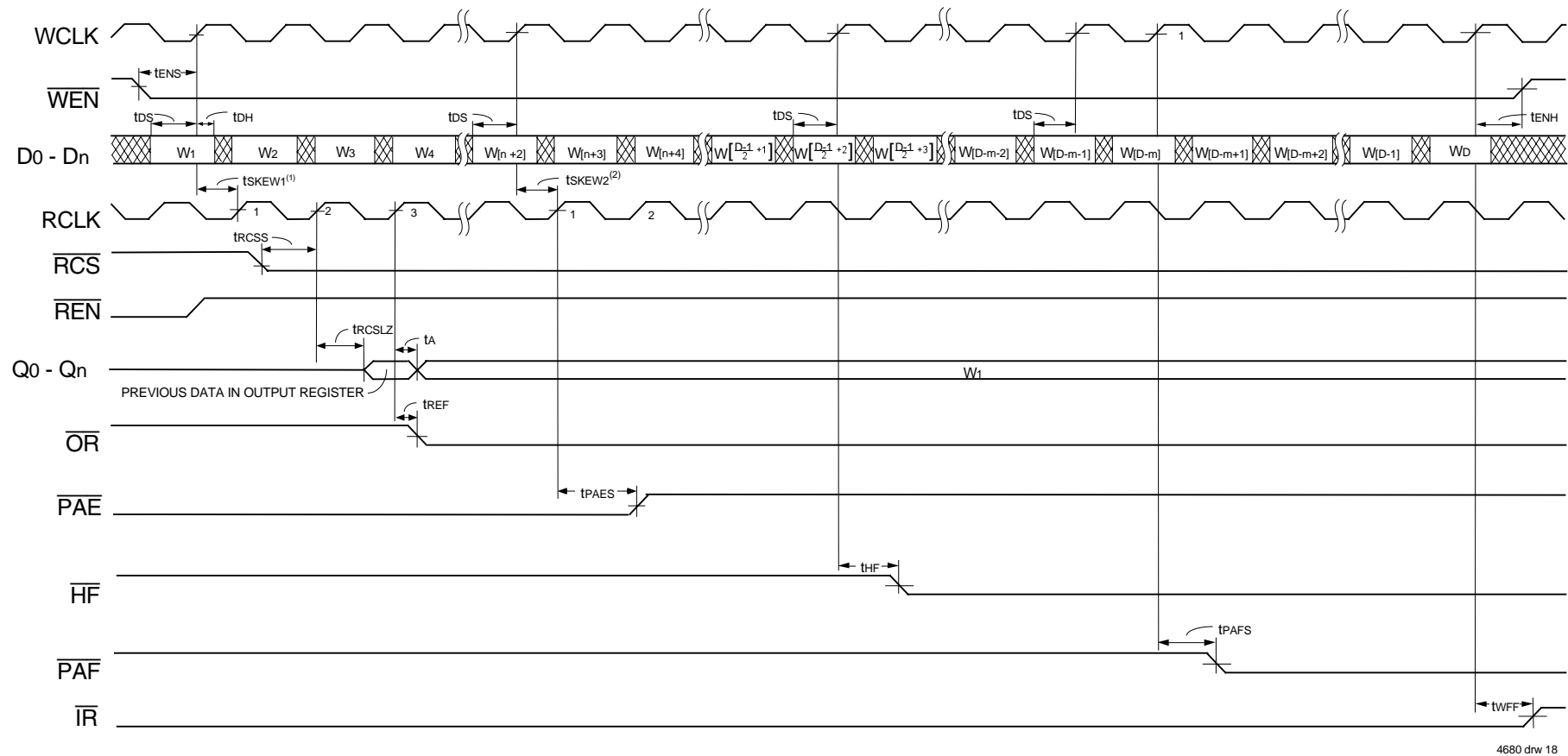
NOTES:

1. t_{SKEW1} is the minimum time between a rising WCLK edge and a rising RCLK edge to guarantee that \overline{OR} will go LOW after two RCLK cycles plus t_{REF} . If the time between the rising edge of WCLK and the rising edge of RCLK is less than t_{SKEW1} , then \overline{OR} assertion may be delayed one extra RCLK cycle.
2. t_{SKEW2} is the minimum time between a rising WCLK edge and a rising RCLK edge to guarantee that \overline{PAE} will go HIGH after one RCLK cycle plus t_{PAES} . If the time between the rising edge of WCLK and the rising edge of RCLK is less than t_{SKEW2} , then the \overline{PAE} deassertion may be delayed one extra RCLK cycle.
3. $\overline{LD} = \text{HIGH}$, $\overline{OE} = \text{LOW}$
4. $n = \text{PAE offset}$, $m = \text{PAF offset}$ and $D = \text{maximum FIFO depth}$.
5. $D = 513$ for IDT72V7230, 1,025 for IDT72V7240, 2,049 for IDT72V7250, 4,097 for IDT72V7260, 8,193 for IDT72V7270, 16,385 for the IDT72V7280, 32,769 for the IDT72V7290 and 65,537 for the IDT72V72100.
6. First data word latency = $t_{SKEW1} + 2 \cdot \text{TrCLK} + t_{REF}$.

Figure 13. Write Timing (First Word Fall Through Mode)

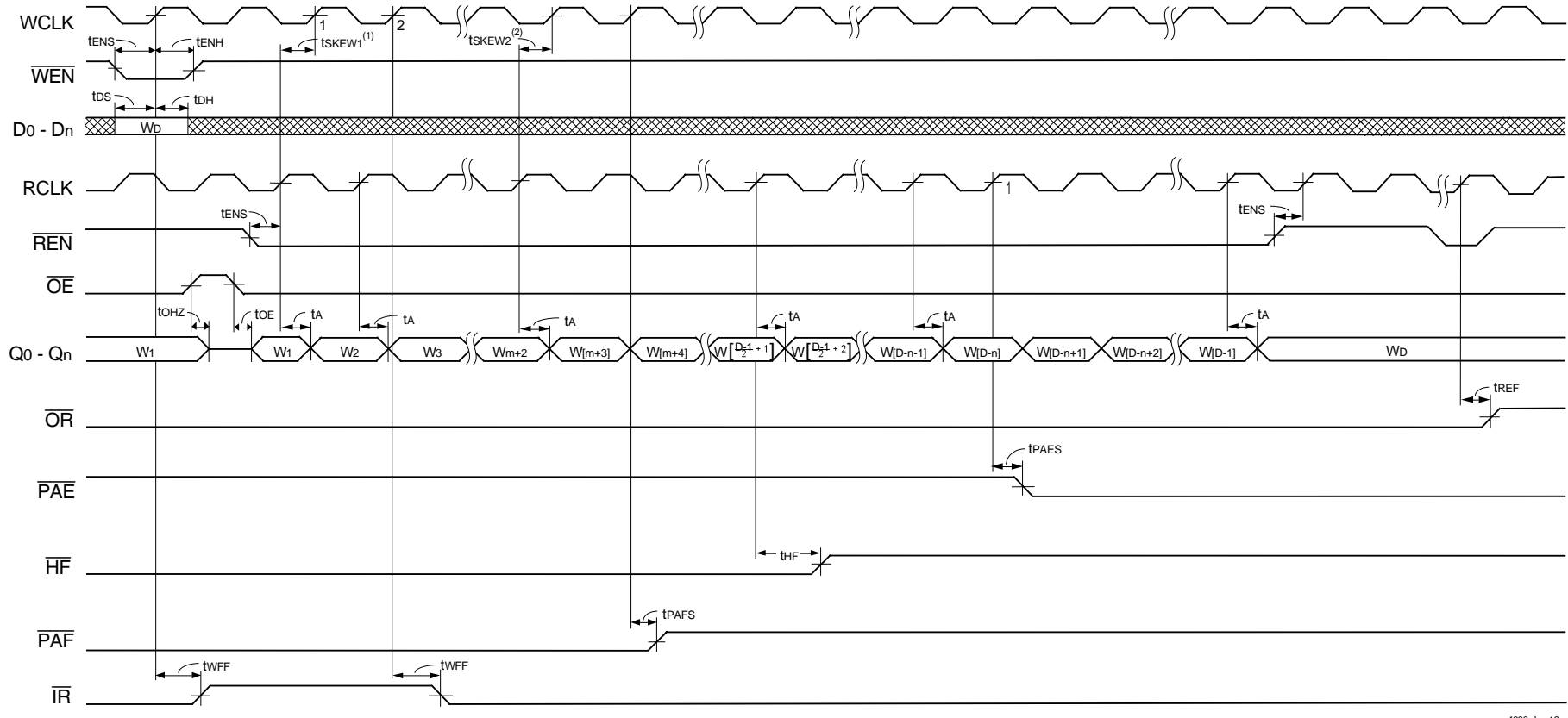

4680 drw 19

NOTES:

1. t_{SKEW1} is the minimum time between a rising RCLK edge and a rising WCLK edge to guarantee that \overline{IR} will go LOW after one WCLK cycle plus t_{WFF} . If the time between the rising edge of RCLK and the rising edge of WCLK is less than t_{SKEW1} , then the \overline{IR} assertion may be delayed one extra WCLK cycle.
2. t_{SKEW2} is the minimum time between a rising RCLK edge and a rising WCLK edge to guarantee that \overline{PAF} will go HIGH after one WCLK cycle plus t_{PAFS} . If the time between the rising edge of RCLK and the rising edge of WCLK is less than t_{SKEW2} , then the \overline{PAF} deassertion may be delayed one extra WCLK cycle.
3. $\overline{LD} = \text{HIGH}$.
4. $n = \overline{PAE}$ Offset, $m = \overline{PAF}$ offset and $D = \text{maximum FIFO depth}$.
5. $D = 513$ for IDT72V7230, 1,025 for IDT72V7240, 2,049 for IDT72V7250, 4,097 for IDT72V7260, 8,193 for IDT72V7270, 16,385 for the IDT72V7280, 32,769 for the IDT72V7290 and 65,537 for the IDT72V72100.
6. $RCS = \text{LOW}$.

Figure 14. Read Timing (First Word Fall Through Mode)

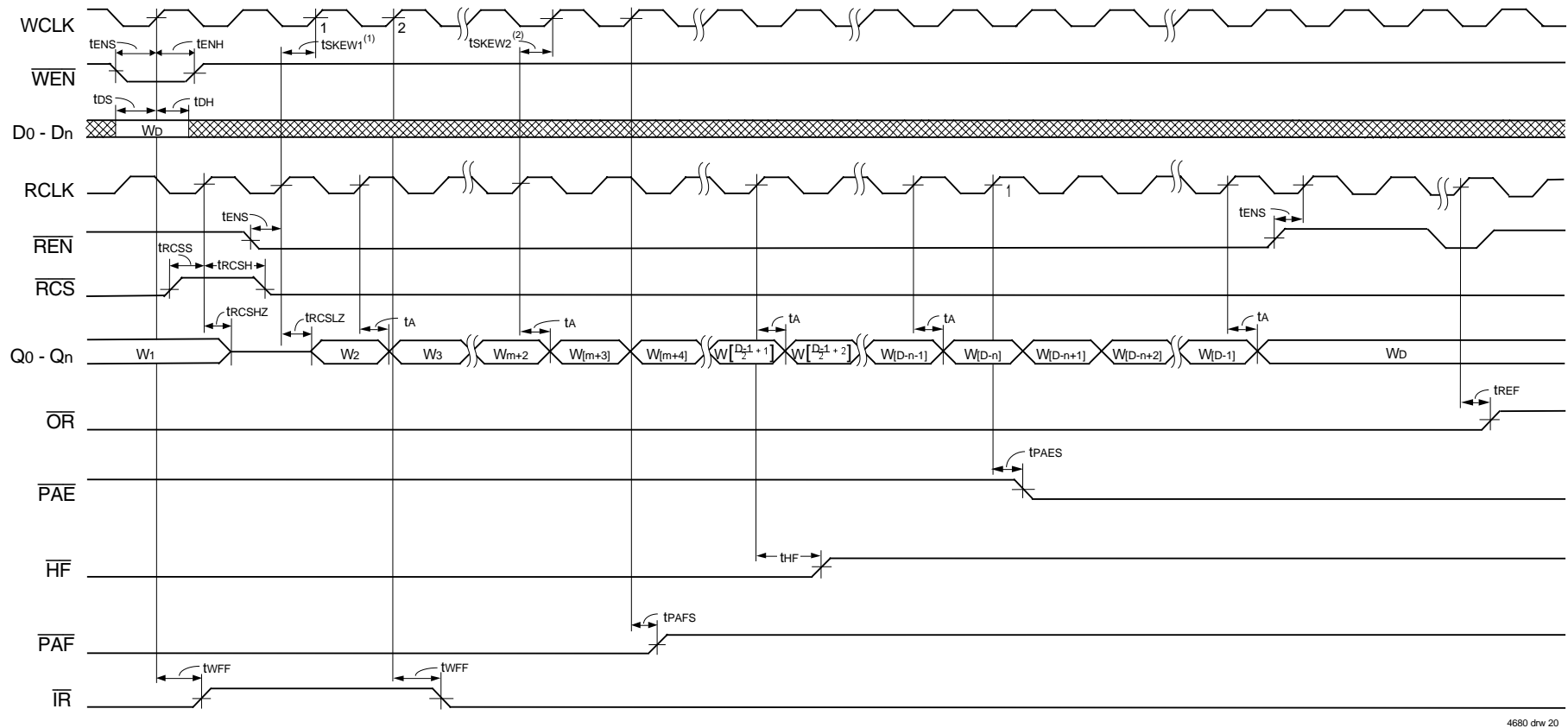

4680 drw 20

NOTES:

1. t_{SKEW1} is the minimum time between a rising RCLK edge and a rising WCLK edge to guarantee that \overline{IR} will go LOW after one WCLK cycle plus t_{WFF} . If the time between the rising edge of RCLK and the rising edge of WCLK is less than t_{SKEW1} , then the \overline{IR} assertion may be delayed one extra WCLK cycle.
2. t_{SKEW2} is the minimum time between a rising RCLK edge and a rising WCLK edge to guarantee that \overline{PAF} will go HIGH after one WCLK cycle plus t_{PAFS} . If the time between the rising edge of RCLK and the rising edge of WCLK is less than t_{SKEW2} , then the \overline{PAF} deassertion may be delayed one extra WCLK cycle.
3. $\overline{LD} = \text{HIGH}$.
4. $n = \overline{PAE}$ Offset, $m = \overline{PAF}$ offset and $D = \text{maximum FIFO depth}$.
5. $D = 513$ for IDT72V7230, 1,025 for IDT72V7240, 2,049 for IDT72V7250, 4,097 for IDT72V7260, 8,193 for IDT72V7270, 16,385 for the IDT72V7280, 32,769 for the IDT72V7290 and 65,537 for the IDT72V72100.
6. $\overline{OE} = \text{LOW}$.

Figure 15. Read Cycle and Read Chip Select Timing (First Word Fall Through Mode)

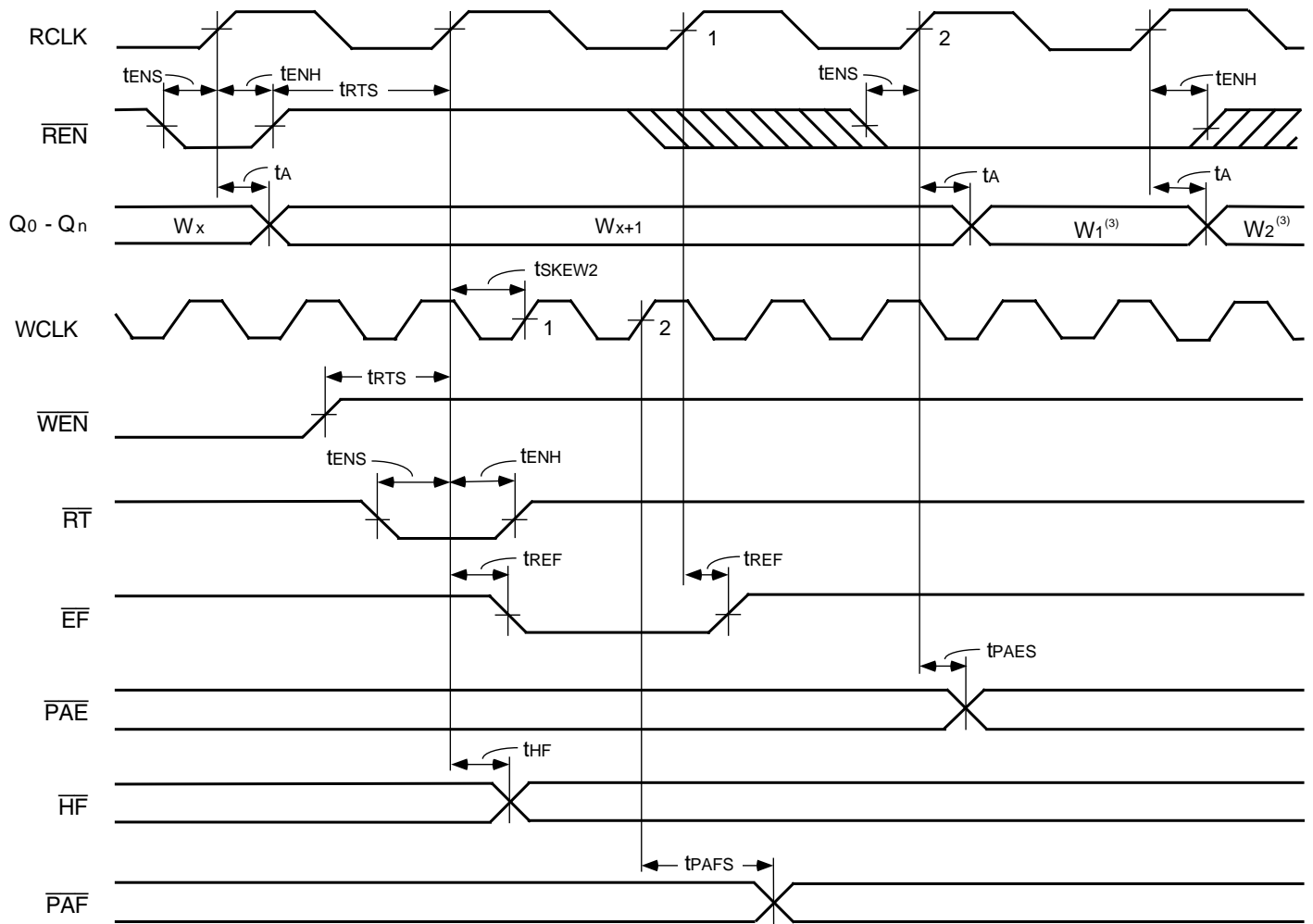

4680 drw21

NOTES:

1. Retransmit setup is complete after \overline{EF} returns HIGH, only then can a read operation begin.
2. $\overline{OE} = \text{LOW}$; $\overline{RCS} = \text{LOW}$.
3. W_1 = first word written to the FIFO after Master Reset, W_2 = second word written to the FIFO after Master Reset.
4. No more than $D - 2$ may be written to the FIFO between Reset (Master or Partial) and Retransmit setup. Therefore, \overline{FF} will be HIGH throughout the Retransmit setup procedure.
 $D = 512$ for IDT72V7230, 1,024 for IDT72V7240, 2,048 for IDT72V7250, 4,096 for IDT72V7260, 8,192 for IDT72V7270, 16,384 for the IDT72V7280, 32,768 for the IDT72V7290 and 65,536 for the IDT72V72100.
5. There must be at least two words written to the FIFO before a Retransmit operation can be invoked.
6. RM is set HIGH during MRS.

Figure 16. Retransmit Timing (IDT Standard Mode)

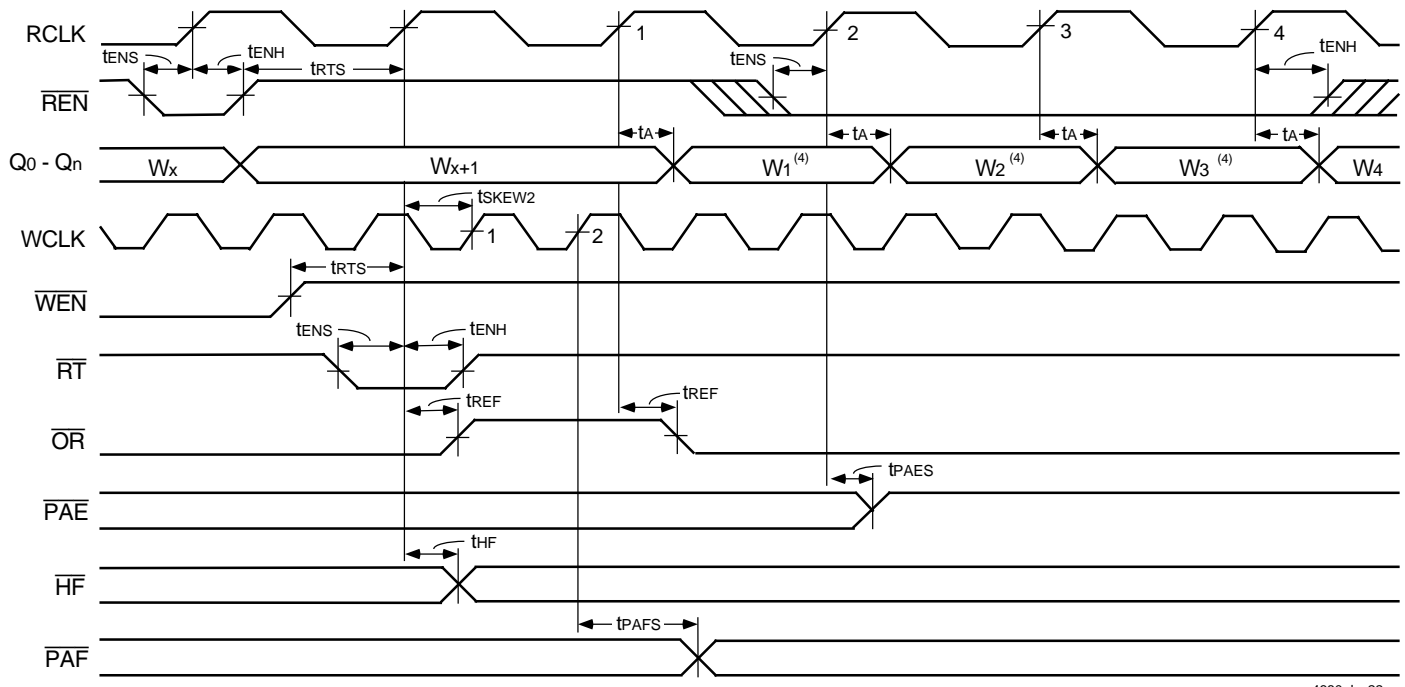

4680 drw22

NOTES:

- Retransmit setup is complete after \overline{OR} returns LOW.
- No more than $D - 2$ words may be written to the FIFO between Reset (Master or Partial) and Retransmit setup. Therefore, \overline{IR} will be LOW throughout the Retransmit setup procedure. $D = 513$ for the IDT72V7230, 1,025 for the IDT72V7240, 2,049 for the IDT72V7250, 4,097 for the IDT72V7260, 8,193 for the IDT72V7270, 16,385 for the IDT72V7280, 32,769 for the IDT72V7290 and 65,537 for the IDT72V72100.
- $\overline{OE} = \text{LOW}$; $\overline{RCS} = \text{LOW}$.
- W_1, W_2, W_3 = first, second and third words written to the FIFO after Master Reset.
- There must be at least two words written to the FIFO before a Retransmit operation can be invoked.
- RM is set HIGH during MRS.

Figure 17. Retransmit Timing (FWFT Mode)

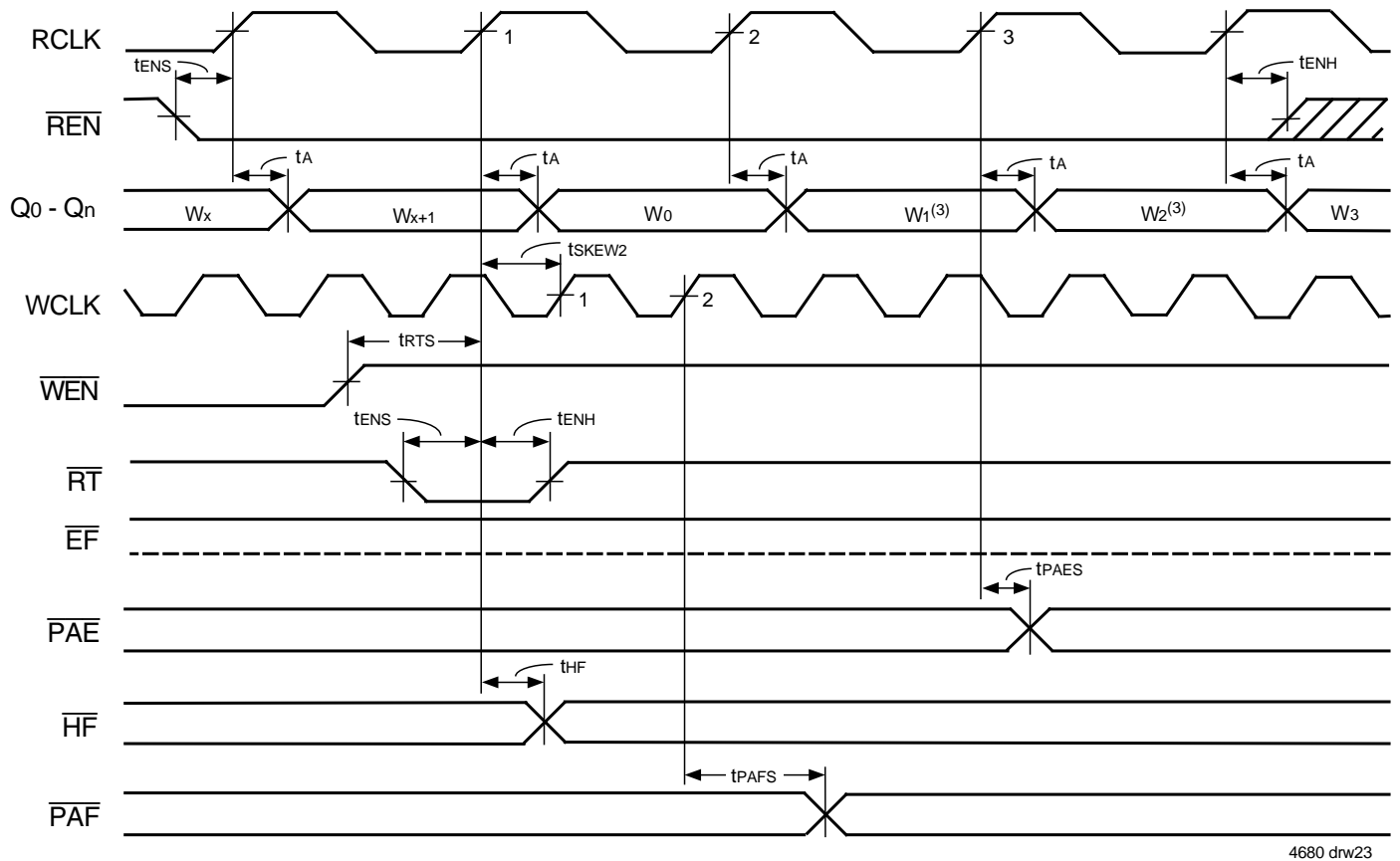

4680 drw23

NOTES:

1. If the part is empty at the point of Retransmit, the empty flag (\overline{EF}) will be updated based on RCLK (Retransmit clock cycle), valid data will also appear on the output.
2. $\overline{OE} = \text{LOW}$; $\overline{RSC} = \text{LOW}$.
3. W_1 = first word written to the FIFO after Master Reset, W_2 = second word written to the FIFO after Master Reset.
4. No more than $D - 2$ may be written to the FIFO between Reset (Master or Partial) and Retransmit setup. Therefore, \overline{FF} will be HIGH throughout the Retransmit setup procedure.
 $D = 512$ for IDT72V7230, 1,024 for IDT72V7240, 2,048 for IDT72V7250, 4,096 for IDT72V7260, 8,192 for IDT72V7270, 16,384 for the IDT72V7280, 32,768 for the IDT72V7290 and 65,536 for the IDT72V72100.
5. There must be at least two words written to the FIFO before a Retransmit operation can be invoked.
6. RM is set LOW during MRS.

Figure 18. Zero Latency Retransmit Timing (IDT Standard Mode)

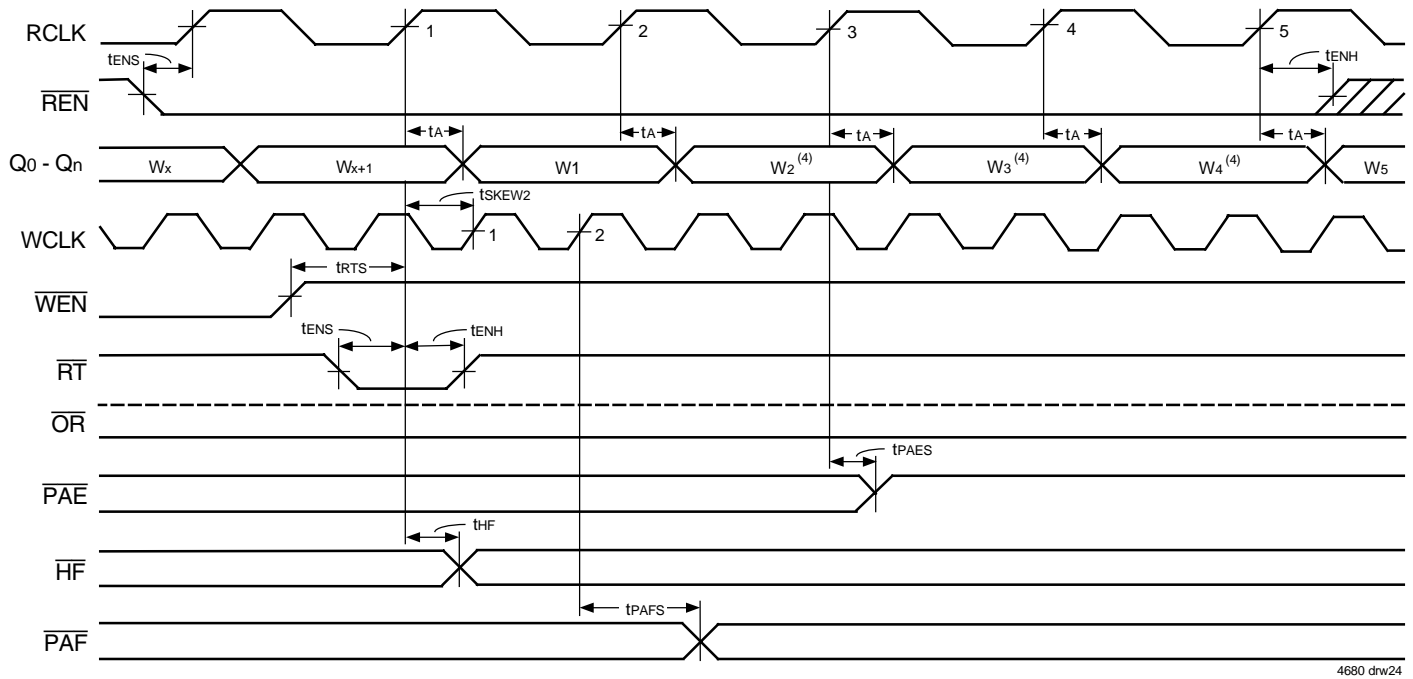

4680 drw24

NOTES:

1. If the part is empty at the point of Retransmit, the output ready flag (\overline{OR}) will be updated based on RCLK (Retransmit clock cycle), valid data will also appear on the output.
2. No more than D - 2 words may be written to the FIFO before Retransmit (Master or Partial) and Retransmit setup. Therefore, \overline{IR} will be LOW throughout the Retransmit setup procedure. D = 513 for the IDT72V7230, 1,025 for the IDT72V7240, 2,049 for the IDT72V7250, 4,097 for the IDT72V7260, 8,193 for the IDT72V7270, 16,385 for the IDT72V7280, 32,769 for the IDT72V7290 and 65,537 for the IDT72V72100.
3. \overline{OE} = LOW; \overline{RCS} = LOW.
4. W1, W2, W3 = first, second and third words written to the FIFO after Master Reset.
5. There must be at least two words written to the FIFO before a Retransmit operation can be invoked.
6. RM is set LOW during MRS.

Figure 19. Zero Latency Retransmit Timing (FWFT Mode)

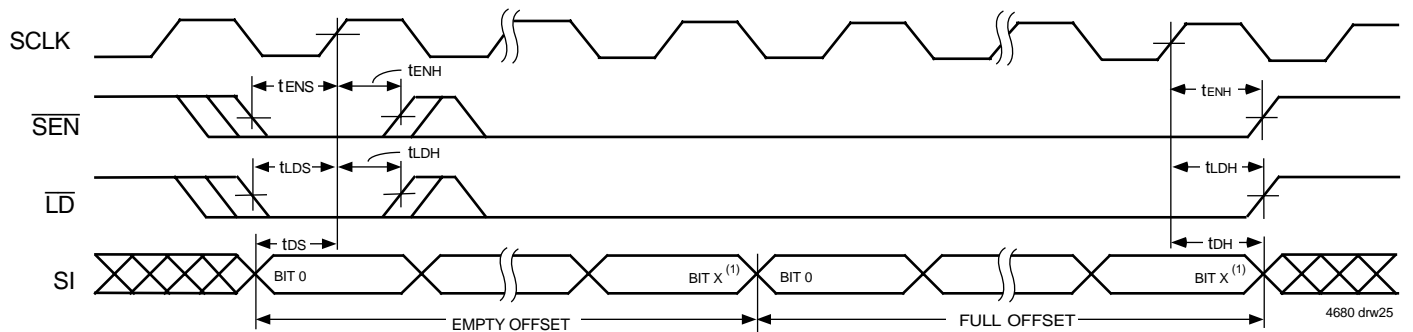

4680 drw25

NOTE:

1. X = 8 for the IDT72V7230, X = 9 for the IDT72V7240, X = 10 for the IDT72V7250, X = 11 for the IDT72V7260, X = 12 for the IDT72V7270, X = 13 for the IDT72V7280, X = 14 for the IDT72V7290 and X = 15 for the IDT72V72100.

Figure 20. Serial Loading of Programmable Flag Registers (IDT Standard and FWFT Modes)

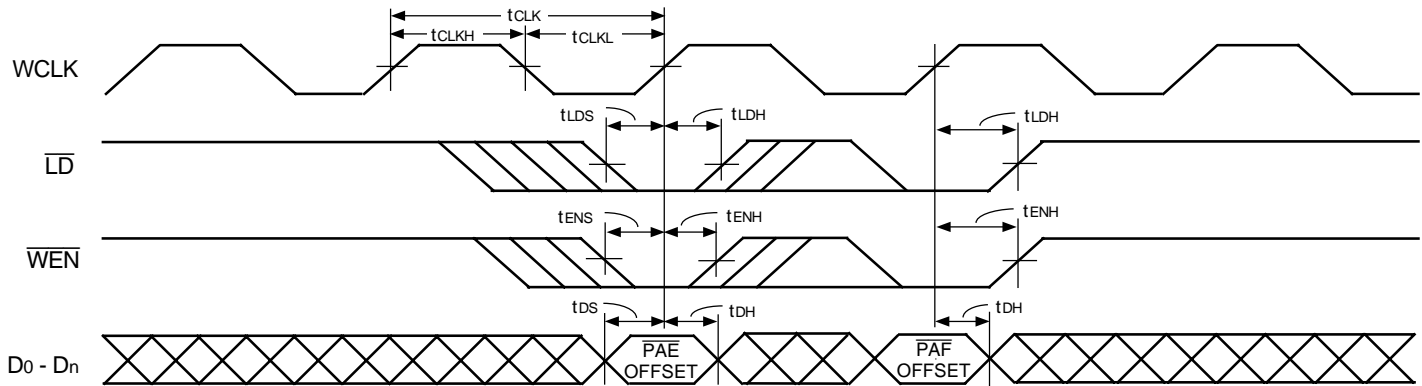

Figure 21. Parallel Loading of Programmable Flag Registers (IDT Standard and FWFT Modes)

4680 drw26

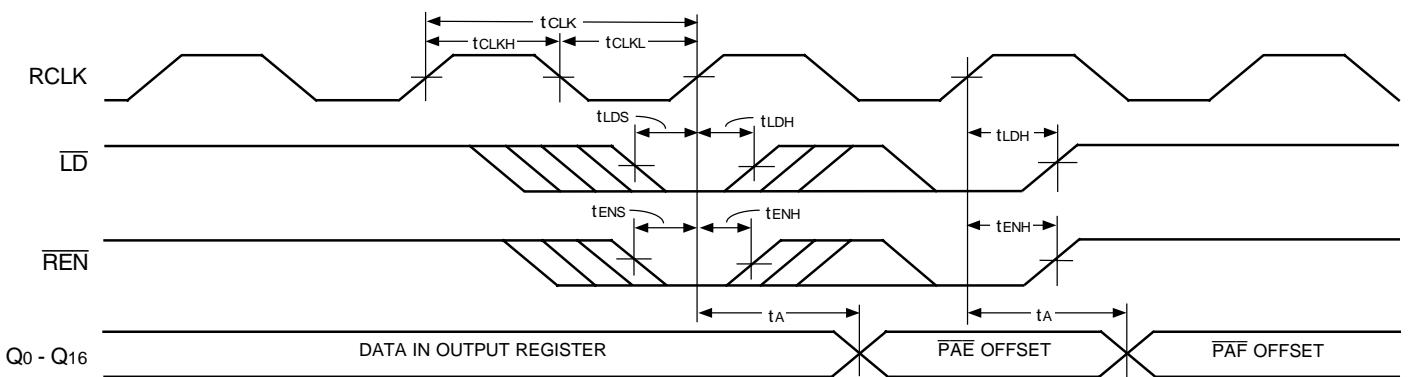
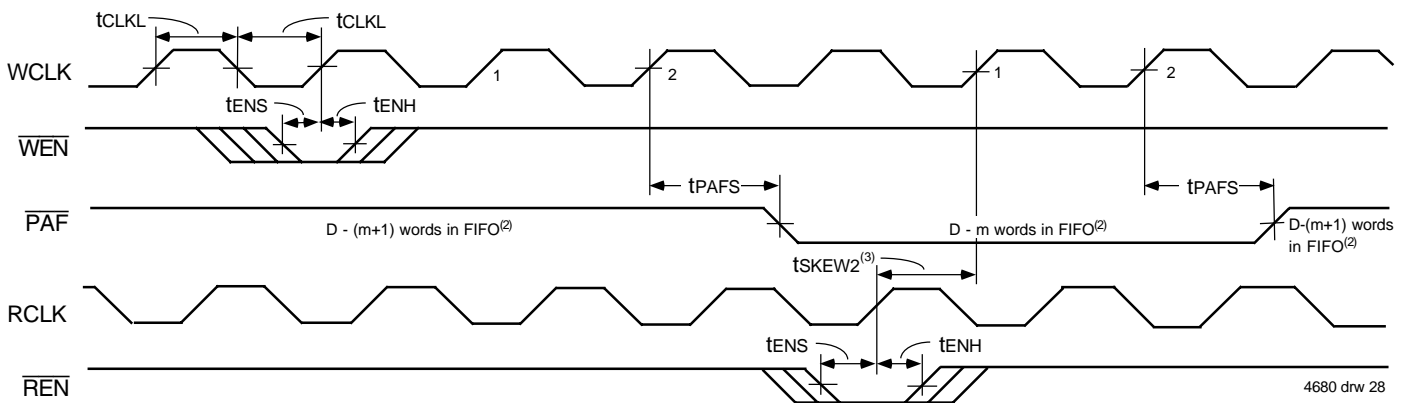

Figure 22. Parallel Read of Programmable Flag Registers (IDT Standard and FWFT Modes)

4680 drw27

NOTES:

1. \overline{OE} = LOW; \overline{RCS} = LOW.



4680 drw 28

NOTES:

1. m = \overline{PAF} offset.

2. D = maximum FIFO depth.

In IDT Standard mode: D = 512 for the IDT72V7230, 1,024 for the IDT72V7240, 2,048 for the IDT72V7250, 4,096 for the IDT72V7260 and 8,192 for the IDT72V7270, 16,384 for the IDT72V7280, 32,768 for the IDT72V7290 and 65,536 for the IDT72V72100.

In FWFT mode: D = 513 for the IDT72V7230, 1,025 for the IDT72V7240, 2,049 for the IDT72V7250, 4,097 for the IDT72V7260, 8,193 for the IDT72V7270, 16,385 for the IDT72V7280, 32,769 for the IDT72V7290 and 65,537 for the IDT72V72100.

3. t_{SKEW2} is the minimum time between a rising RCLK edge and a rising WCLK edge to guarantee that \overline{PAF} will go HIGH (after one WCLK cycle plus t_{PAFS}). If the time between the rising edge of RCLK and the rising edge of WCLK is less than t_{SKEW2} , then the \overline{PAF} deassertion time may be delayed one extra WCLK cycle.

4. \overline{PAF} is asserted and updated on the rising edge of WCLK only.

5. Select this mode by setting PFM HIGH during Master Reset.

Figure 23. Synchronous Programmable Almost-Full Flag Timing (IDT Standard and FWFT Modes)

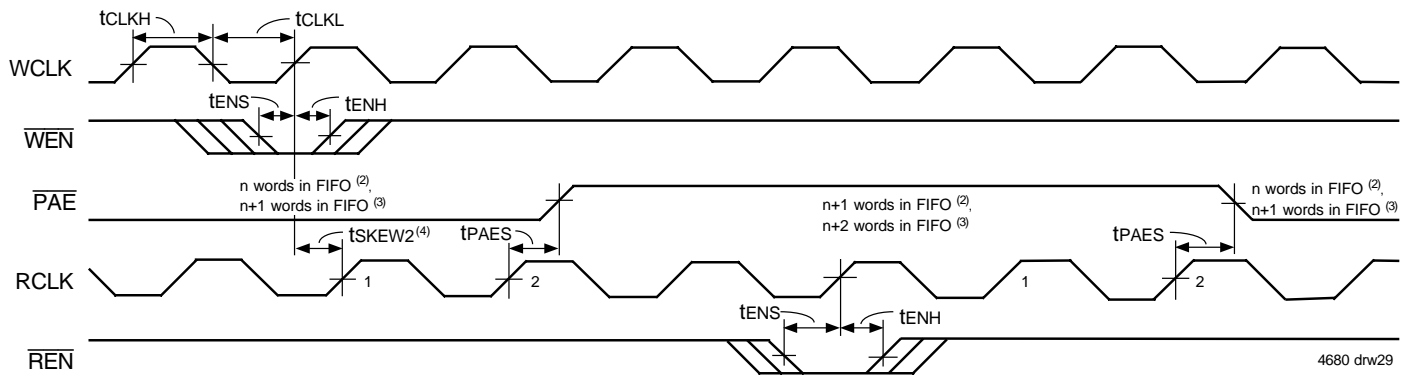

4680 drw29

NOTES:

1. $n = \overline{PAE}$ offset.
2. For IDT Standard mode
3. For FWFT mode.
4. t_{SKEW2} is the minimum time between a rising WCLK edge and a rising RCLK edge to guarantee that \overline{PAE} will go HIGH (after one RCLK cycle plus t_{PAES}). If the time between the rising edge of WCLK and the rising edge of RCLK is less than t_{SKEW2} , then the \overline{PAE} deassertion may be delayed one extra RCLK cycle.
5. \overline{PAE} is asserted and updated on the rising edge of WCLK only.
6. Select this mode by setting PFM HIGH during Master Reset.
7. RCS is LOW.

Figure 24. Synchronous Programmable Almost-Empty Flag Timing (IDT Standard and FWFT Modes)

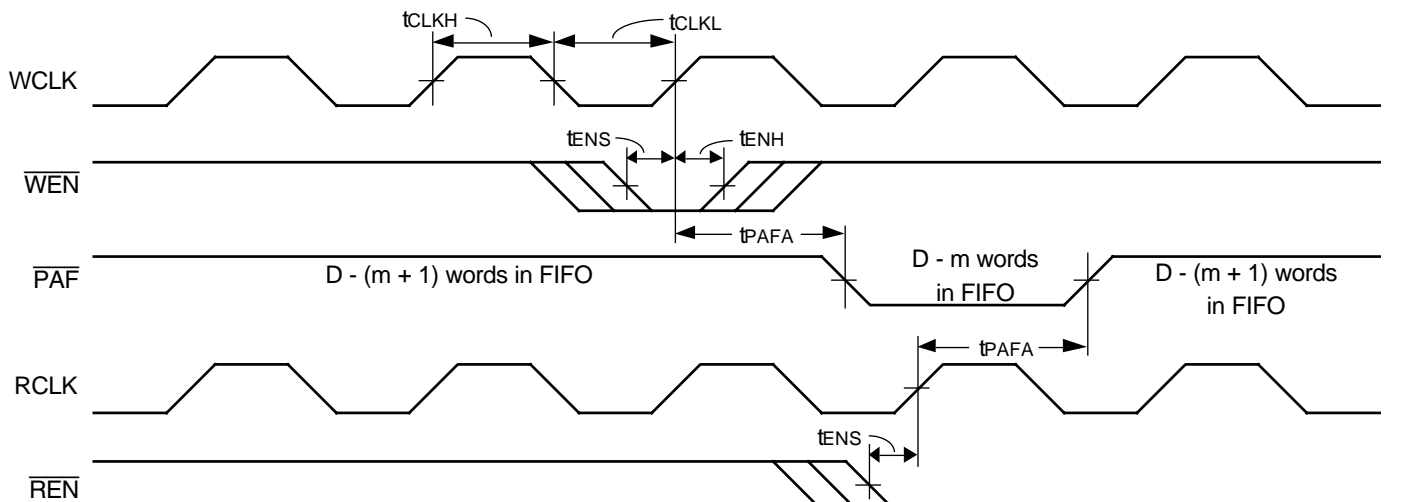

4680 drw30

NOTES:

1. $m = \overline{PAF}$ offset.
2. $D =$ maximum FIFO Depth.
In IDT Standard Mode: $D = 512$ for the IDT72V7230, 1,024 for the IDT72V7240, 2,048 for the IDT72V7250, 4,096 for the IDT72V7260, 8,192 for the IDT72V7270, 16,384 for the IDT72V7280, 32,768 for the IDT72V7290 and 65,536 for the IDT72V72100.
In FWFT Mode: $D = 513$ for the IDT72V7230, 1,025 for the IDT72V7240, 2,049 for the IDT72V7250, 4,097 for the IDT72V7260, 8,193 for the IDT72V7270, 16,385 for the IDT72V7280, 32,769 for the IDT72V7290 and 65,537 for the IDT72V72100.
3. \overline{PAF} is asserted to LOW on WCLK transition and reset to HIGH on RCLK transition.
4. Select this mode by setting PFM LOW during Master Reset.

Figure 25. Asynchronous Programmable Almost-Full Flag Timing (IDT Standard and FWFT Modes)

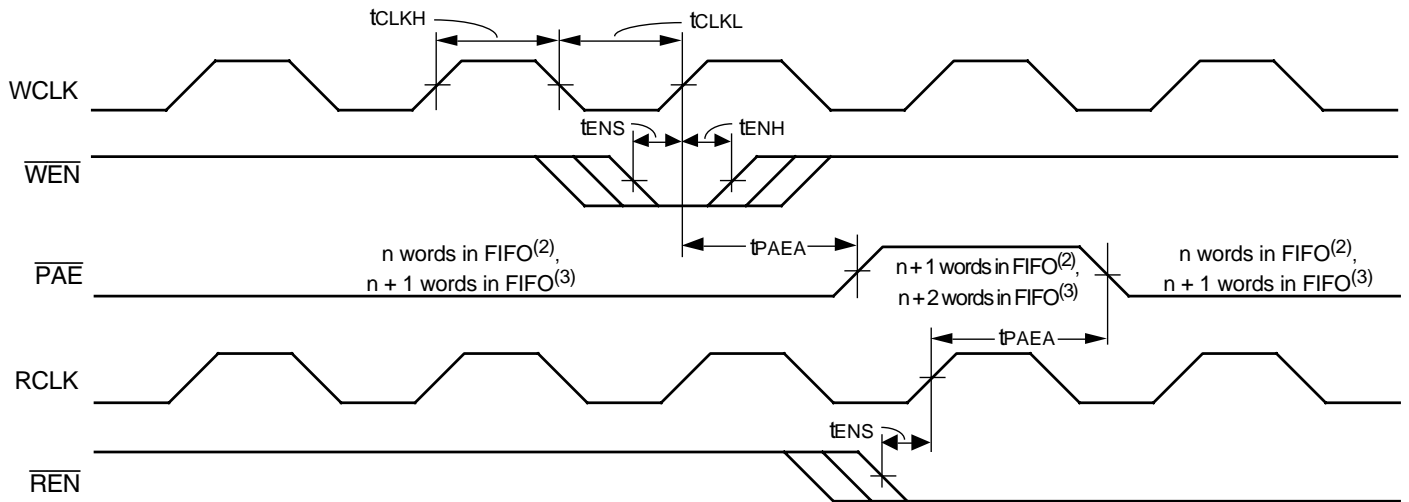

4680 drw 31

NOTES:

1. $n = \overline{\text{PAE}}$ offset.
2. For IDT Standard Mode.
3. For FWFT Mode.
4. $\overline{\text{PAE}}$ is asserted LOW on RCLK transition and reset to HIGH on WCLK transition.
5. Select this mode by setting PFM LOW during Master Reset.

Figure 26. Asynchronous Programmable Almost-Empty Flag Timing (IDT Standard and FWFT Modes)

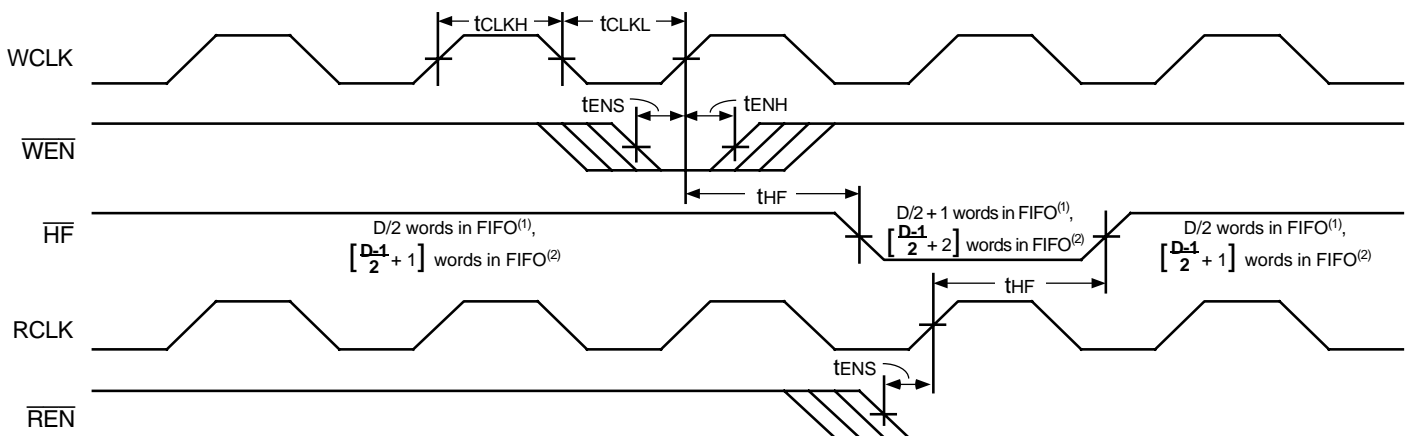

4680 drw32

NOTES:

1. In IDT Standard mode: D = maximum FIFO depth. D = 512 for the IDT72V7230, 1,024 for the IDT72V7240, 2,048 for the IDT72V7250, 4,096 for the IDT72V7260, 8,192 for the IDT72V7270, 16,384 for the IDT72V7280, 32,768 for the IDT72V7290 and 65,536 for the IDT72V72100.
2. In FWFT mode: D = maximum FIFO depth. D = 513 for the IDT72V7230, 1,025 for the IDT72V7240, 2,049 for the IDT72V7250, 4,097 for the IDT72V7260, 8,193 for the IDT72V7270, 16,385 for the IDT72V7280, 32,769 for the IDT72V7290 and 65,537 for the IDT72V72100.

Figure 27. Half-Full Flag Timing (IDT Standard and FWFT Modes)

OPTIONAL CONFIGURATIONS

WIDTH EXPANSION CONFIGURATION

Word width may be increased simply by connecting together the control signals of multiple devices. Status flags can be detected from any one device. The exceptions are the \overline{EF} and \overline{FF} functions in IDT Standard mode and the \overline{IR} and \overline{OR} functions in FWFT mode. Because of variations in skew between RCLK and WCLK, it is possible for $\overline{EF}/\overline{FF}$ deassertion and $\overline{IR}/\overline{OR}$ assertion to vary by one cycle between FIFOs. In IDT Standard mode, such problems can be

avoided by creating composite flags, that is, ANDing \overline{EF} of every FIFO, and separately ANDing \overline{FF} of every FIFO. In FWFT mode, composite flags can be created by ORing \overline{OR} of every FIFO, and separately ORing \overline{IR} of every FIFO.

Figure 28 demonstrates a width expansion using two IDT72V7230/72V7240/72V7250/72V7260/72V7270/72V7280/72V7290/72V72100 devices. D0 - D71 from each device form a 144-bit wide input bus and Q0-Q71 from each device form a 144-bit wide output bus. Any word width can be attained by adding additional IDT72V7230/72V7240/72V7250/72V7260/72V7270/72V7280/72V7290/72V72100 devices.

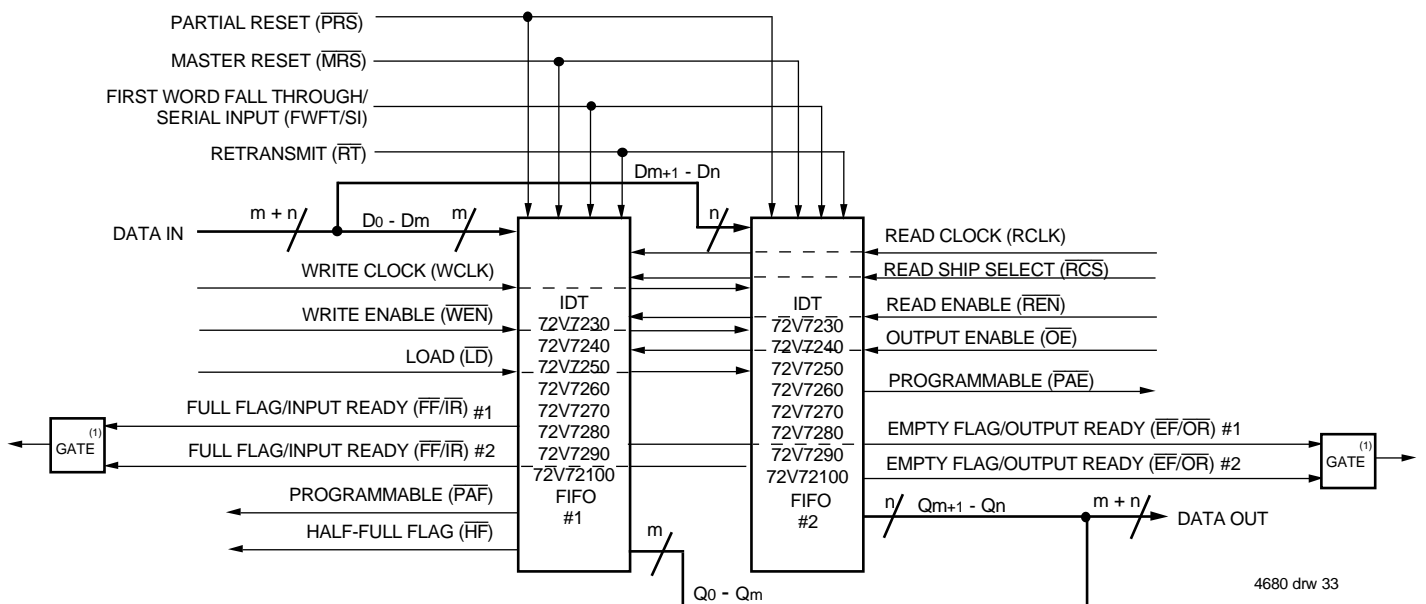

NOTES:

1. Use an AND gate in IDT Standard mode, an OR gate in FWFT mode.
2. Do not connect any output control signals directly together.
3. FIFO #1 and FIFO #2 must be the same depth, but may be different word widths.

Figure 28. Block Diagram of 512x 144, 1,024x 144, 2,048x 144, 4,096x 144, 8,192x 144, 16,384x 144, 32,768x 144 and 65,536x 144 Width Expansion

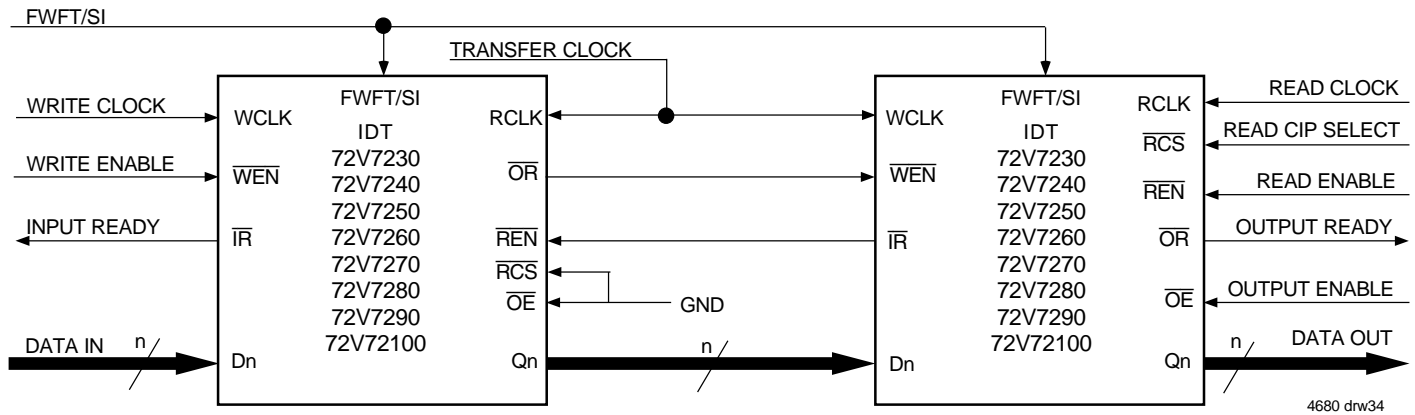

Figure 29. Block Diagram of 1,024 x 72, 2,048 x 72, 4,096 x 72, 8,192 x 72, 16,384 x 72, 32,768 x 72, 65,572 x 72 and 131,072 x 72 Depth Expansion

DEPTH EXPANSION CONFIGURATION (FWFT MODE ONLY)

The IDT72V7230 can easily be adapted to applications requiring depths greater than 512, 1,024 for the IDT72V7240, , 2,048 for the IDT72V7250, 4,096 for the IDT72V7260, 8,192 for the IDT72V7270, 16,384 for the IDT72V7280, 32,768 for the IDT72V7290 and 65,536 for the IDT72V72100 with an 18-bit bus width. In FWFT mode, the FIFOs can be connected in series (the data outputs of one FIFO connected to the data inputs of the next) with no external logic necessary. The resulting configuration provides a total depth equivalent to the sum of the depths associated with each single FIFO. Figure 29 shows a depth expansion using two IDT72V7230/72V7240/72V7250/72V7260/72V7270/72V7280/72V7290/72V72100 devices.

Care should be taken to select FWFT mode during Master Reset for all FIFOs in the depth expansion configuration. The first word written to an empty configuration will pass from one FIFO to the next ("ripple down") until it finally appears at the outputs of the last FIFO in the chain – no read operation is necessary but the RCLK of each FIFO must be free-running. Each time the data word appears at the outputs of one FIFO, that device's OR line goes LOW, enabling a write to the next FIFO in line.

For an empty expansion configuration, the amount of time it takes for OR of the last FIFO in the chain to go LOW (i.e. valid data to appear on the last FIFO's outputs) after a word has been written to the first FIFO is the sum of the delays for each individual FIFO:

$$(N - 1) * (4 * \text{transfer clock}) + 3 * \text{TRCLK}$$

where N is the number of FIFOs in the expansion and TRCLK is the RCLK period. Note that extra cycles should be added for the possibility that the tskew1

specification is not met between WCLK and transfer clock, or RCLK and transfer clock, for the OR flag.

The "ripple down" delay is only noticeable for the first word written to an empty depth expansion configuration. There will be no delay evident for subsequent words written to the configuration.

The first free location created by reading from a full depth expansion configuration will "bubble up" from the last FIFO to the previous one until it finally moves into the first FIFO of the chain. Each time a free location is created in one FIFO of the chain, that FIFO's IR line goes LOW, enabling the preceding FIFO to write a word to fill it.

For a full expansion configuration, the amount of time it takes for IR of the first FIFO in the chain to go LOW after a word has been read from the last FIFO is the sum of the delays for each individual FIFO:

$$(N - 1) * (3 * \text{transfer clock}) + 2 * \text{TWCLK}$$

where N is the number of FIFOs in the expansion and TWCLK is the WCLK period. Note that extra cycles should be added for the possibility that the tskew1 specification is not met between RCLK and transfer clock, or WCLK and transfer clock, for the IR flag.

The Transfer Clock line should be tied to either WCLK or RCLK, whichever is faster. Both these actions result in data moving, as quickly as possible, to the end of the chain and free locations to the beginning of the chain.

ORDERING INFORMATION

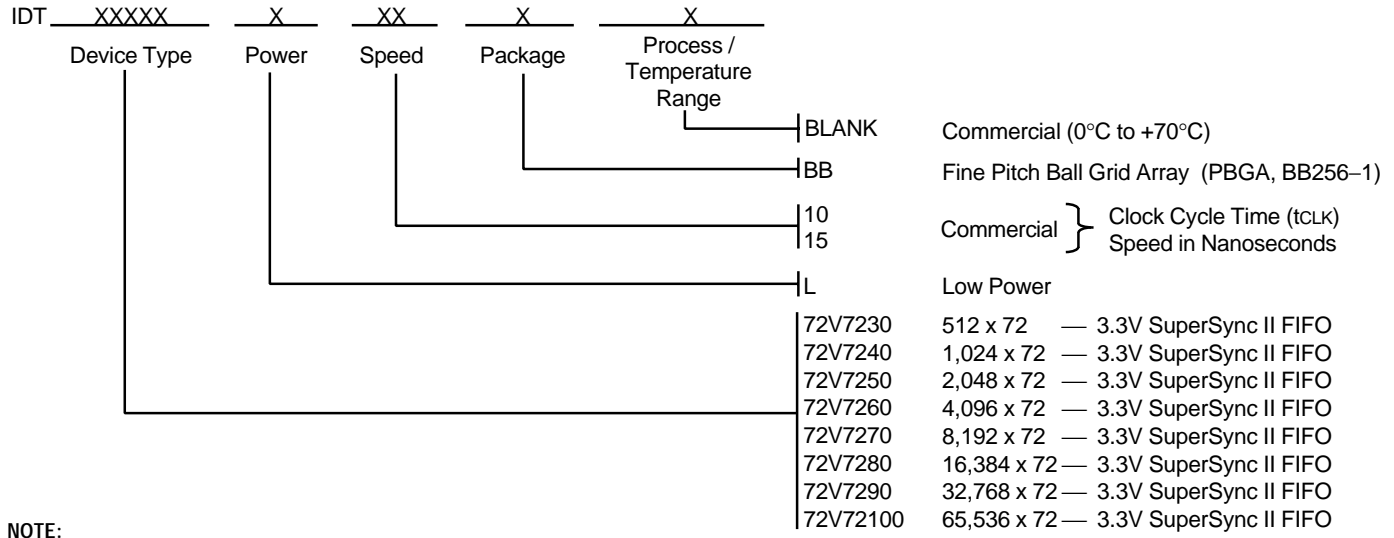

NOTE:
1. Industrial temperature range is available by special order.

4680 drw35

DATASHEET DOCUMENT HISTORY

6/01/2000 pgs. 1, 2, 3, 7, 33, 34, 34, 35, 38, 41 and 42
 11/1/2000 pgs. 1, 2 and 42
 1/10/2001 pgs. 7



CORPORATE HEADQUARTERS
 2975 Stender Way
 Santa Clara, CA 95054

for SALES:
 800-345-7015 or 408-727-6116
 fax: 408-492-8674
 www.idt.com*

for Tech Support:
 408-330-1753
 email: FIFOhelp@idt.com
 PBGA Pkg: www.idt.com/docs/PSC4081.pdf

*To search for sales office near you, please click the sales button found on our home page or dial the 800# above and press 2.
 The SuperSync II FIFO is a trademark and the IDT logo is a registered trademark of Integrated Device Technology, Inc.