



c) **Data Interpretation**

- 1) Pick two points on the line you drew on your graph and find the slope using

$$\text{slope} = \frac{\text{voltage}_A - \text{voltage}_B}{\text{current}_A - \text{current}_B}$$

**voltage<sub>A</sub> - voltage<sub>B</sub> represents the difference in voltage between two points, and current<sub>A</sub> - current<sub>B</sub> represents the difference in current between the points. Dividing these quantities gives the amount of voltage per unit of current.**

- 2) Compare your answer for the slope of the graph in part 1) above to your calculated resistance of the nichrome wire in the third column of the data table on the previous page.

**To find the resistances, solve  $V = IR$  for  $R$ :  $R = V/I$  You should find that the calculated resistance is approximately equal to the slope of the graph.**

- 3) Explain the physical meaning of the slope of your graph.

**The slope of  $V$  versus  $I = V/I = R$ . The slope is the resistance of the wire.**

- 4) How does your answer compare to the resistance you measured for the thin 30 cm nichrome wire in Activity 11.5.b?

**In Activity 11.5.b you measured the resistance of the thin 30 cm wire using a multimeter. Here you calculate its resistance by measuring the voltage across the wire and the current flowing through it.**

**Activity 12.2: What Is the Result of Adding Resistors in Series?**

- a) We will use single bulb trays to determine the effect of adding resistors in series.

- 1) Connect a single bulb tray to a 3-battery tray. Note the brightness of the bulb.
- 2) Now connect a second single bulb tray in series with the first bulb. What happens to the brightness of the bulb? **Both bulbs are equally bright, but they are dimmer than when only one bulb was connected to the batteries.**
- 3) What will happen if you connect a third single bulb tray in series with the first two bulb trays? Prediction:      Answer: **All 3 bulbs are even dimmer.**
- 4) How does the amount of current flowing through the circuit change as more bulbs are added in series? Why?

**The amount of current decreases as more bulbs are added in series, so the bulbs are dimmer. Adding resistors in series increases the total circuit resistance. Since the voltage provided by the batteries does not change, the increased circuit resistance means less current flows through the circuit.**

- b) Next we examine the total resistance of the circuit when resistors are added in series. Disconnect the batteries from the circuit. Use a **digital multimeter** to measure the resistances and record the values in the table.

Load Device	Resistance (in ohms)
All 3 bulbs connected together	
First single bulb tray	
Second single bulb tray	
Third single bulb tray	

How does the total resistance of the circuit compare to the resistances of the single bulb trays?

**The resistance of all 3 bulbs connected together is slightly greater than the sum of the resistances of the 3 single bulb trays.**

- c) Group Discussion Question: If the sum of the resistances of the 3 single bulb trays does not equal the resistance of the circuit when all three bulb trays are connected together, why is this so?

**The wires connecting the 3 single bulb trays have some resistance.**

### Activity 12.3: What is the Result of Adding Resistors in Parallel?

#### a) Bulb trays

- 1) Connect a 4-bulb tray to a 3-battery tray with connecting wires. Are the bulbs in the tray wired together in series or in parallel? parallel Explain how to tell whether bulbs are connected in series or parallel by examining the circuit and by turning individual bulbs off and on.

**By examining the bulb tray, you can see that separate gray wires connect each bulb, that is, not all of the circuit current flows through each bulb. If you unscrew one bulb, the other bulbs remain lit. If the bulbs were connected in series and you removed one bulb, an open circuit would result and none of the bulbs would light.**

- 2) Disconnect the battery tray from the 4-bulb tray. Unscrew all but one of the bulbs. Measure the resistance across the entire bulb tray with a digital multimeter. \_\_\_\_\_
- 3) Screw in a second bulb and measure the resistance across the tray. \_\_\_\_\_
- 4) Predict what will happen when the third bulb is screwed in. \_\_\_\_\_  
Check your prediction by measuring the resistance. \_\_\_\_\_
- 5) What happens to the total resistance of a circuit when resistors are added in parallel? Explain why resistors in parallel have this effect.

**As more resistors (bulbs) are added, the resistance of the bulb tray decreases. Each added bulb adds another resistor to the circuit. But, since the bulbs are connected in parallel, each bulb also adds another path for current to flow. The increased number of paths in the circuit reduces the circuit's resistance.**

- 6) A circuit consists of one 4 ohm resistor connected in parallel to a 6 ohm resistor. Calculate the total resistance of the circuit, assuming that these resistors are the only sources of resistance in the circuit.

$$\frac{1}{R_{Tot}} = \frac{1}{R_1} + \frac{1}{R_2} = \frac{1}{4 \Omega} + \frac{1}{6 \Omega} = \frac{3}{12 \Omega} + \frac{2}{12 \Omega} = \frac{5}{12 \Omega}$$

$$R_{Tot} = \frac{12 \Omega}{5} = 2.4 \Omega$$

**b) Human resistance**

- 1) Use an **analog multimeter** to measure the resistance between your hands. (Before taking the measurement, reset the meter by connecting the two meter leads together and setting the meter scale to zero.) \_\_\_\_\_
- 2) Using 4 hollow metal rods, connect 3 people into a series circuit. (Each person holds a rod in one hand and grasps the end of the rod held by the next person.) Measure the resistance of your series circuit with the analog multimeter. \_\_\_\_\_

- 3) How does the resistance of the circuit compare to the sum of the resistances of the 3 people? Series circuit resistance: \_\_\_\_\_ Sum of individual resistances: \_\_\_\_\_

**The circuit resistance is about equal to the sum of the individual resistances.**

- 4) Using two rods, connect 3 people into a parallel circuit. (Each person puts one hand on each of the rods.) Measure the resistance of this parallel circuit. \_\_\_\_\_
- 5) Would you expect that adding more people (resistors) in parallel would increase or decrease the total resistance of the circuit?

**Each added parallel pathway decreases the circuit resistance.**

- 6) Is the total resistance of the parallel circuit less than, equal to, or greater than the resistance of an individual person's resistance?

**The circuit resistance is less than the resistance of the person with the smallest individual resistance.**

**Activity 12.4: What Voltage Drops Occur Across Combination Circuits?**

- a) Close the switch on the circuit board and unscrew bulb #3, leaving bulb #1 and bulb #2 connected in a series circuit. Close the switch and observe the brightness of the bulbs.

- 1) Measure the **voltage drop** across bulb #1 with a **digital multimeter**. Record the voltage in the box beside the bulb in the diagram. Repeat for bulb #2.
- 2) Measure the **current** flowing through the circuit by opening the switch and attaching the multimeter leads to either side of the open switch. \_\_\_\_\_
  - a) How much of this current do you think flows through bulb #1? **all of the current**
  - b) How much flows through bulb #2? **all of the current**

- 3) Based on your measurements of voltage and current, how do the resistances of bulbs #1 and #2 compare? Are their resistances approximately equal? yes

Explain how you decided that the resistances of bulbs #1 and #2 are or are not approximately equal.

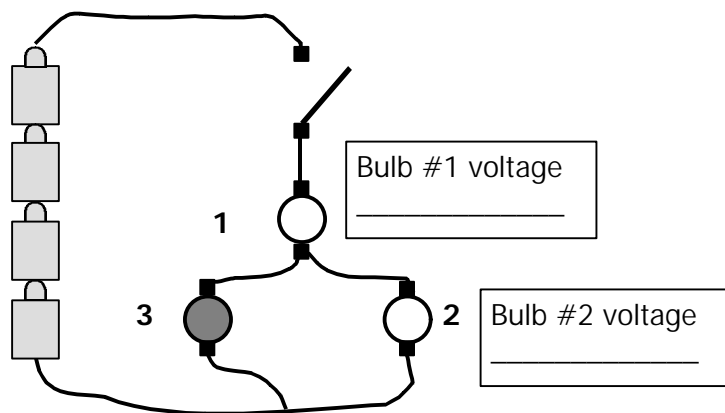

**Since the amount of current flowing through each bulb is equal and the voltage drop across the bulbs is approximately equal, their resistances will be approximately equal:  $R = V/I$**

b) Screw in bulb #3. Bulbs #2 and #3 are now connected in parallel. Bulb #1 is connected in series to the parallel network of bulbs #2 and #3. Close the switch.

- 1) Are the 3 bulbs equally bright? If not, which one is the brightest? **\_bulb #1\_**
- 2) Measure the **voltage drop** across each bulb with a digital multimeter. Record your measurements in the box beside each bulb in the diagram.
- 3) Measure the **current** flowing through the circuit by opening the switch and attaching the multimeter leads to either side of the open switch. \_\_\_\_\_

a) How does this amount of current compare to the current you measured when only two bulbs were lit?  
**\_More current flows\_**

b) How much of this current flows through bulb #1?  
**\_all the current\_**

c) If the bulbs are identical, how much current flows through bulb #2? **\_one-half\_**

d) How much current flows through bulb #3? **\_one-half\_**

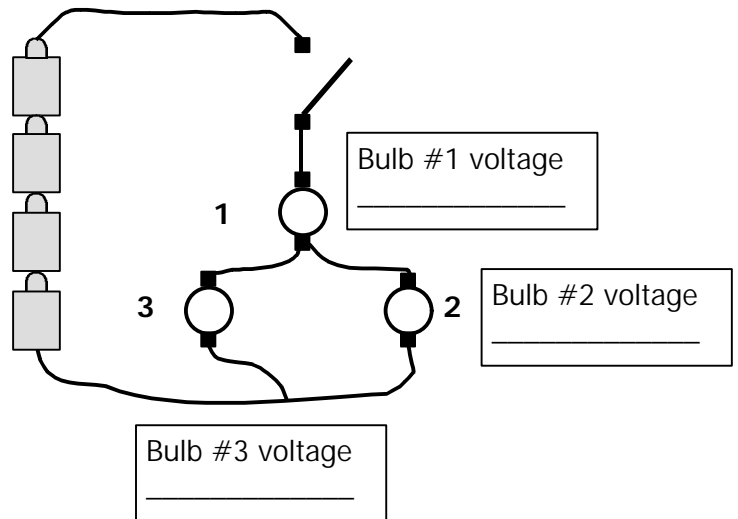

4) Why does more current flow through the circuit when bulb #3 is lit? Explain how adding resistors in parallel changes the resistance of a circuit.

**Screwing in bulb #3 adds another parallel pathway for the current to follow, lowering the overall resistance of the circuit. The more parallel pathways in a circuit, the lower the circuit's resistance. Lower resistance means more current can flow through the circuit.**