

In5Ctrl CMS CSC DDU5, Input Control FPGAs

(file Oddu_in)

4-24-2009_10:46

DF025A06 Version 25

Process Rocket I/O Data from DMB, format output to DDU FIFOs

v20: fix DMBfull-to-JTAG monitor logic

v21: add 2*32 bit Fiber Memory diagnostic (F30,31)

v22: replace F_OK with LFOK for InUnits

r2, use FDP for LFOK; r3, use FOK to control GT PwrDn

v23, RxErr sets SingleWarn, but LRxErr goes on Stat11, Lfilled on Stat30, LDLerr on STAT31

v24: Tune RdBusy logic, extend RHL to 1200ns; r2: add Search/Free Errorrdetection to FMM & L1m2b7

r3: add REN-while-StackMT error to FMM & L1m2b7; r4: new LA signals on 2

r5: try OEF_F/REN_F fix in RdCtrl.9, allows Fiber/NextMem bookeeping when FIFO Empty at EOE

r6: add mode 8-F options for LAs & LEDs; r7: add RstEOE to OEM_fctrl counter, bring BadFW to L0mA

v25: RdCtrl.9 disable LnxtFIFO until NextFiber+6, prevents Previous fiber moving Current Read pointer

r2: Now SCAovfl (DMBerr) does Not set SingleError at InFPGA. r3: modified XMITerr def

r4: DMB FIFO Full no longer sets WARN. r5: fix Reset for InUnit filler/word-phase counter

r6: prevent LastFill for single 8-code case

this DDU:

RXER words are skipped, FILLER added as needed

- Use code "C" with FILL flag set (b34 & b16)

-- could use code "8" instead...

- Should we Reset RxErr Monitor? How?

PART=XC2VP20-6-FG676

AVOID=Y21, E23, C22, E21

(INIT, BUSY, WRITE, CS)

NC_XCV400_FG676=B13, AF13

NC_XCV400E_FG676=D13, Y13

All I/O is 3.3V

INCNTRL

Mode 1 Switch Block

1: Mode Bit 0

2: Mode Bit 1

3: Mode Bit 2

4: Mode Bit 3

7: Set Fake_L1A (data passthrough)

8: Show STAT31-0 on LAs, ~FPGA version on LEDs

PROM=2*XC18V04-VQ44 (PARALLEL)

DDU5in\In5Ctrl\in5ctrl

* af_clb_5x31rpm has Core EDN file

PROGRAM takes < 55ms

NEED TO Change FIFO Full, lost sync NOT Warning....done?

VME Broadcast Addresses:

24=OSU-TCB "Test Control Board"

25=DMB

26=TMB

27=Both DMB and TMB

28=DDU

22=DCC

PromID: 05026093h

FPGAid: 31266093h

ELECTRONICS LAB
PHYSICS DEPARTMENT
THE OHIO STATE UNIVERSITY
174 WEST 18TH AVE
COLUMBUS OHIO 43210

To Do:

- COMPARE L1NUM & BXN (DMB/TMB too)
add BX_offset constants to SRAM?
- use DDU-DMB fiber to STOP DMB on FULL, check
- Watch for TRG buff overflows
- No logic for TXEN, TXDIN, PAE0/1, Mode5/4...OK.
- Add InUnit Check for DMB Timeouts & set FMM Error?

Special Startup Order:

- 2) Release WE
- 3) Release DLL
- 5) En. Outputs
- 6) DONE

DDU Format Since DDUctrl v15:

H1: 0x/5T/NN.NNNN/XXX/LH/VK

H2: 0x/8000/0001/8000/HHHH

H3: 0x/LLLL/oooo/ZZZZ/GGMY

T-2: 0x/8000/FFFF/8000/8000

T-1: 0x/SSSS.SSSS/QQQQ/PPPP

TR: 0x/A/?/WW.WWWW/RRRR/UUMK

DDU WordCount (64-bit words) for "No Data" event: 0x006.
DDU WordCount for one DMB (only one CFEB): 0D2h = 210 dec, 1680 Bytes
DDU WC, 1 DMB with 2 CFEB (8 samples each): 19Ah = 410 dec, 3280 Bytes
DDU WC, 2 DMB with 1 CFEB (nCFEB=2): 19Eh = 414 dec, 3312 Bytes
DDU WC, 2 DMB with 2 CFEB (nCFEB=4): 32Eh = 814 dec, 6512 Bytes

DDU_WordCount = (6 + 25*Nts*nCFEB + 4*nDMB) < 30070; 240560 Bytes

^^Ignores TMB Data^^ GBE_ByteCount = 8*DDU_WordCount 8 TS assumed

DDU WC, 3 DMB with 1 CFEB (nCFEB=3): 26Ah = 618 dec, 4944 Bytes
DDU WC, 4 DMB with 1 CFEB (nCFEB=4): 336h = 822 dec, 6576 Bytes
DDU WC, 7 DMB with 1 CFEB (nCFEB=7): 59Ah = 1434 dec, 11472 Bytes
DDU WC, 8 DMB with 1 CFEB (nCFEB=8): 666h = 1638 dec, 13104 Bytes

DDU WC, 11 DMB with 1 CFEB (nCFEB=11): 8CAh = 2250 dec, 18000 Bytes
DDU WC, 12 DMB with 1 CFEB (nCFEB=12): 996h = 2454 dec, 19632 Bytes
DDU WC, 15 DMB with 1 CFEB (nCFEB=15): BFAh = 3066 dec, 24528 Bytes

Later use FRDY logic to determine when InUnit is killed; allow real-time Kills (until Reset) in case of Errors/Glitches?

Mask DMBs with critical error until they're Reset?

For now just use LFOK.

Single error, insignificant unless repeated

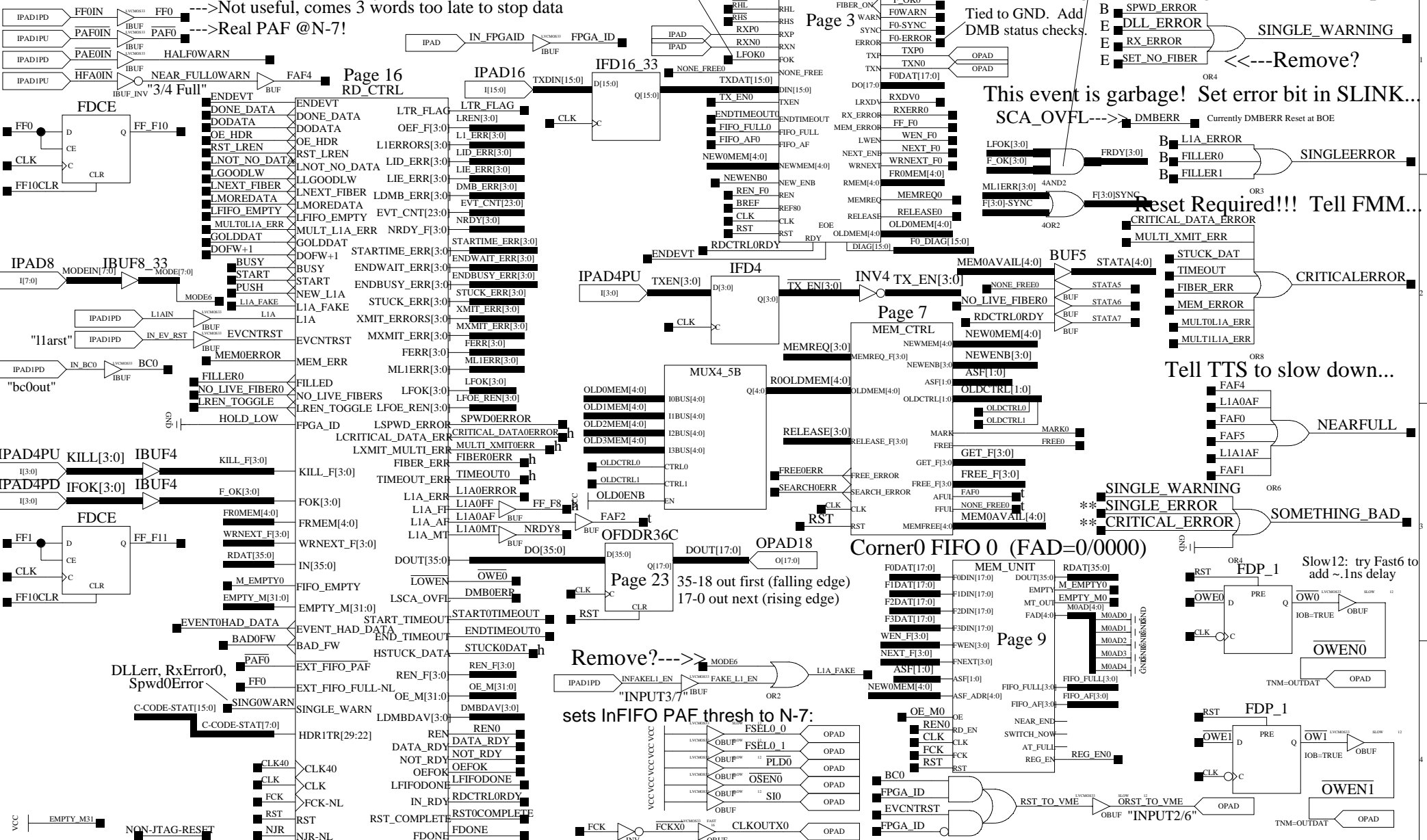

Corner1 FIFO 2 (FAD=1/0010)

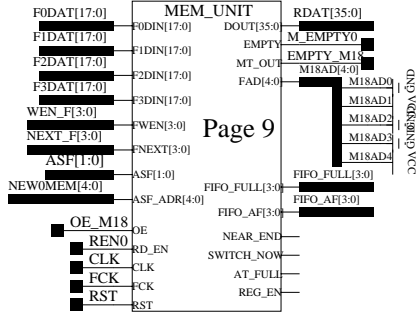

Page 9

Corner1 FIFO 5 (FAD=1/0101)

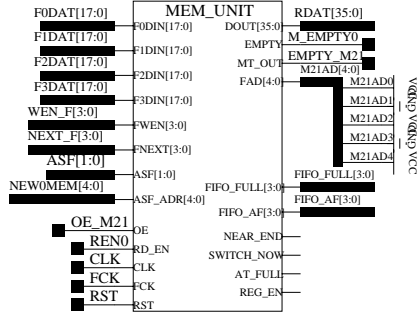

Corner1 FIFO 8* (FAD=1/1000)

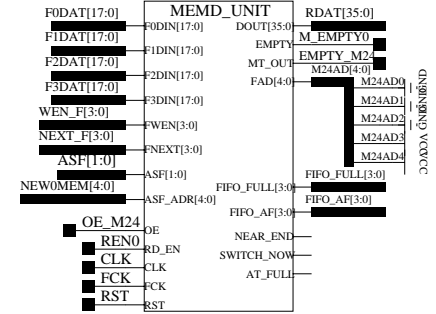

Corner0 FIFO 8* (FAD=0/1000)

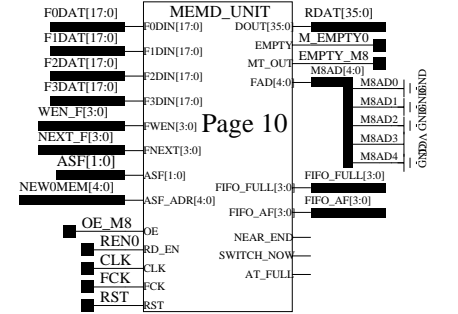

Page 10

Corner1 FIFO 1 (FAD=1/0001)

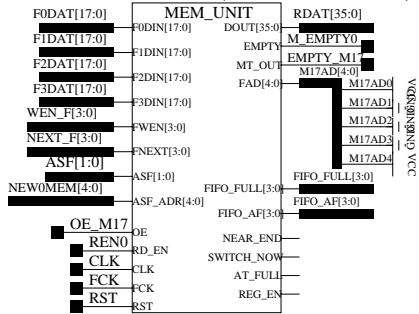

Corner1 FIFO 4 (FAD=1/0100)

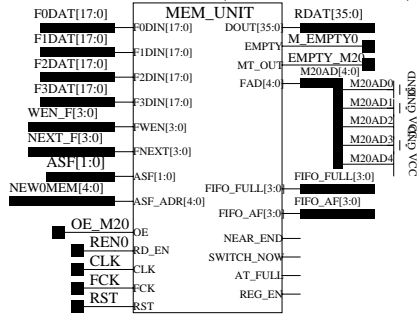

Corner1 FIFO 7 (FAD=1/0111)

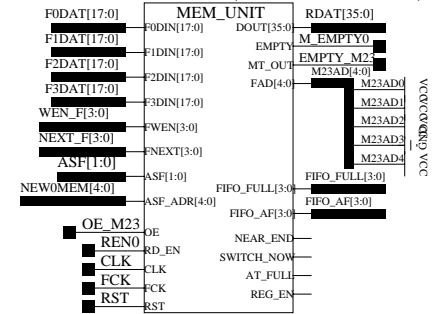

Corner1 FIFO 10 (FAD=1/1010)

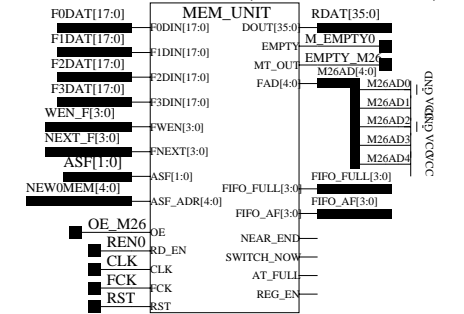

Corner1 FIFO 0 (FAD=1/0000)

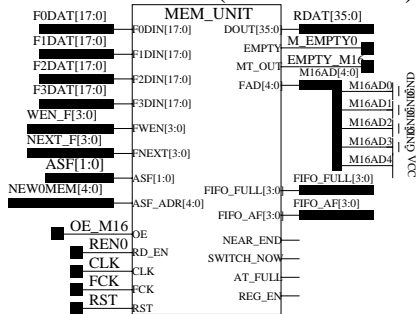

Corner1 FIFO 3 (FAD=1/0011)

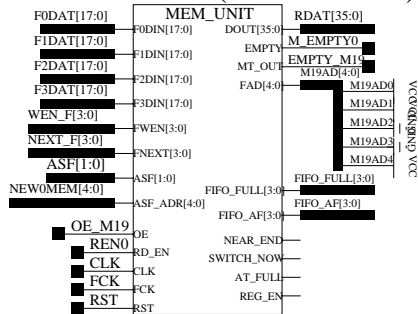

Corner1 FIFO 6 (FAD=1/0110)

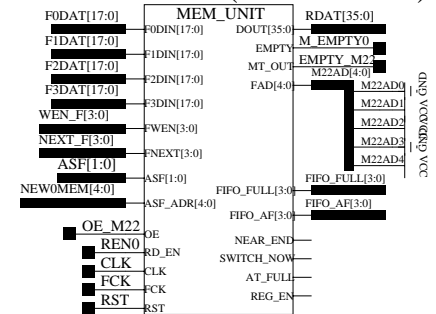

Corner1 FIFO 9 (FAD=1/1001)

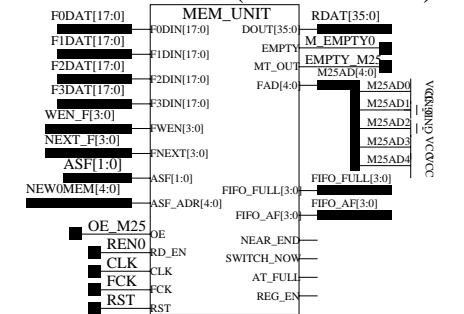

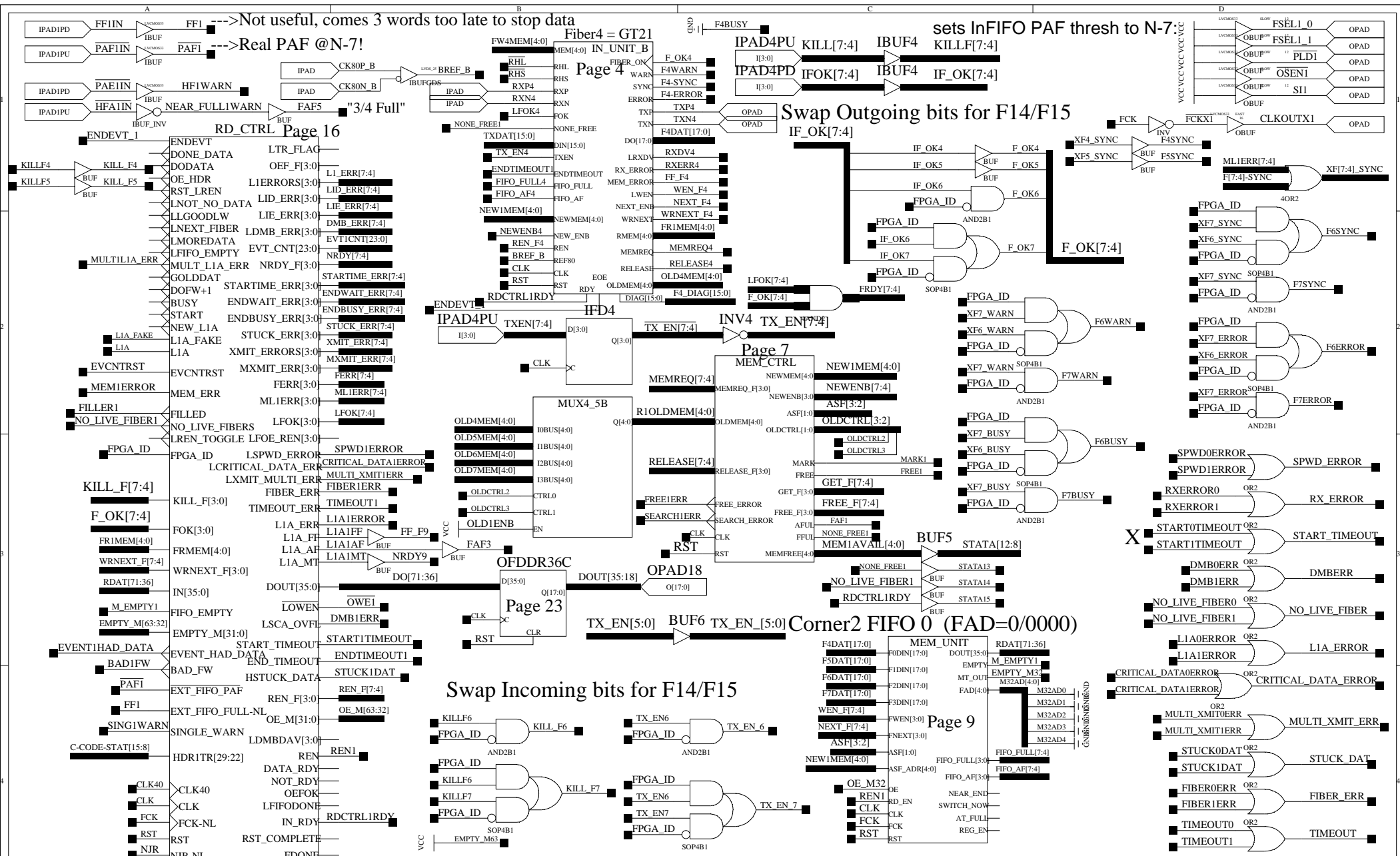

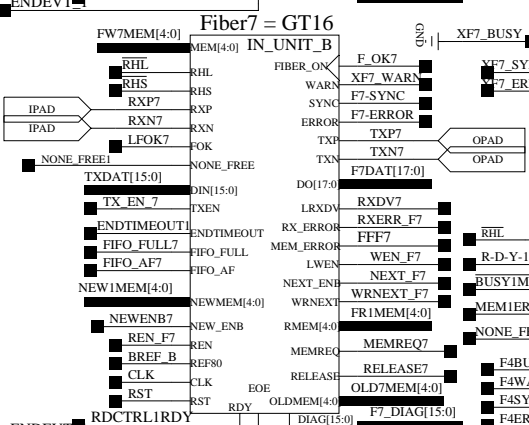
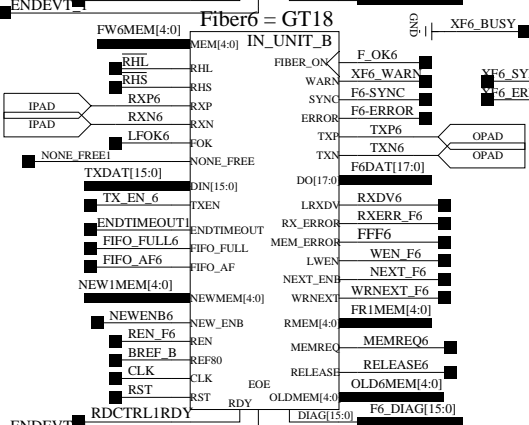
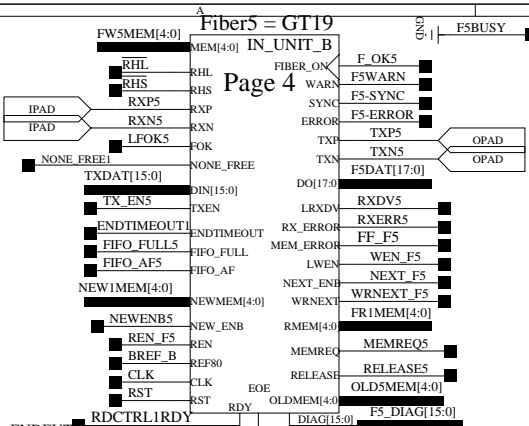

Corner3 FIFO 2 (FAD=1/0010)

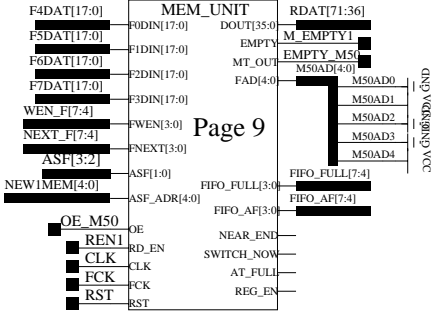

Page 9

Corner3 FIFO 5 (FAD=1/0101)

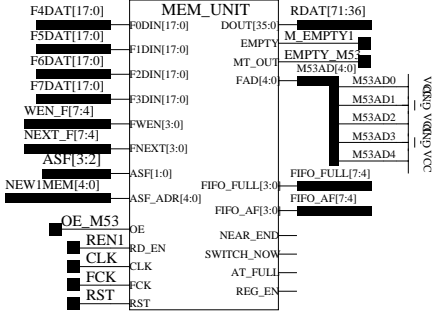

Corner3 FIFO 8* (FAD=1/1000)

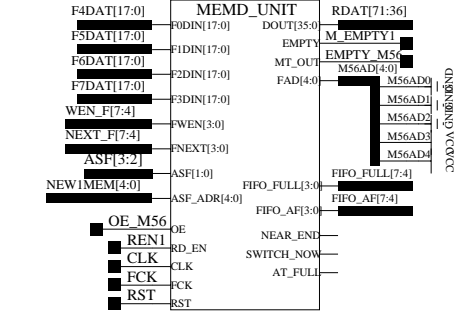

Corner2 FIFO 8* (FAD=1/1000)

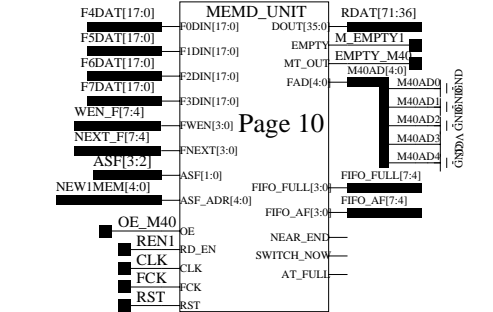

Page 10

Corner3 FIFO 1 (FAD=1/0001)

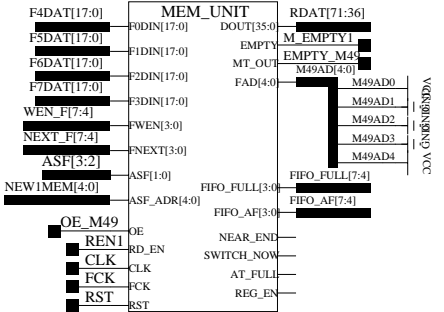

Corner3 FIFO 4 (FAD=1/0100)

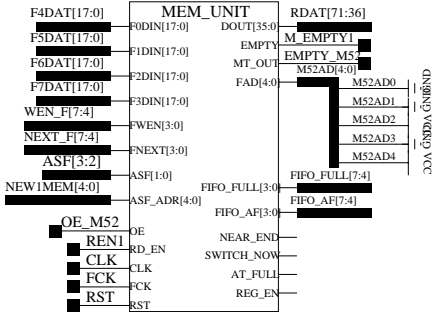

Corner3 FIFO 7 (FAD=1/0111)

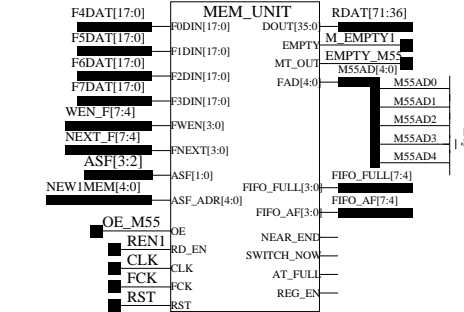

Corner3 FIFO 10 (FAD=1/1010)

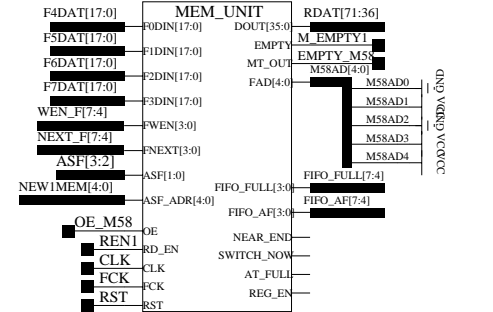

Corner3 FIFO 0 (FAD=1/0000)

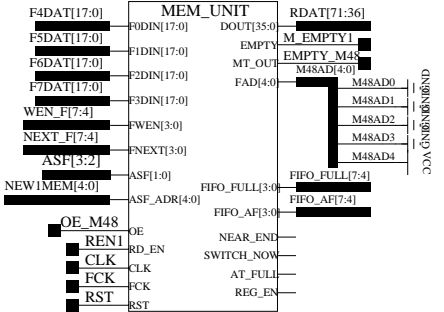

Corner3 FIFO 3 (FAD=1/0011)

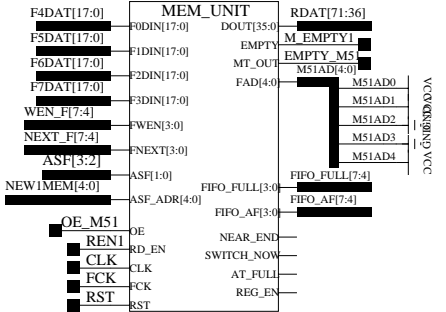

Corner3 FIFO 6 (FAD=1/0110)

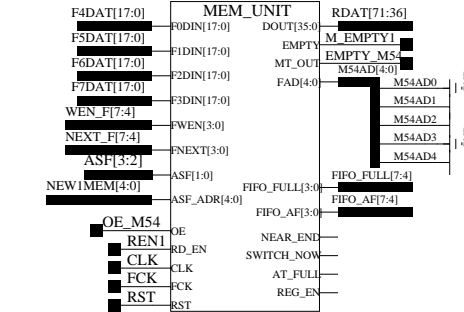

Corner3 FIFO 9 (FAD=1/1001)

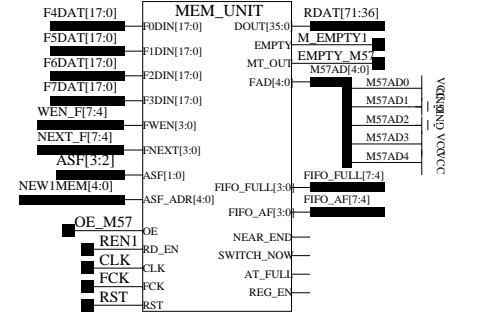

END

NotRdy False means AllRdy or All-MT-->

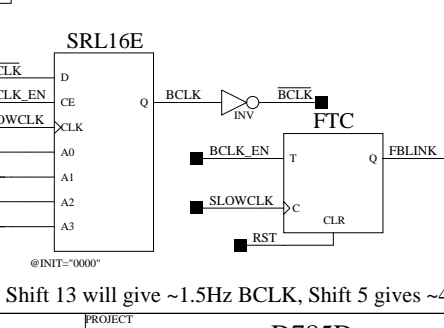
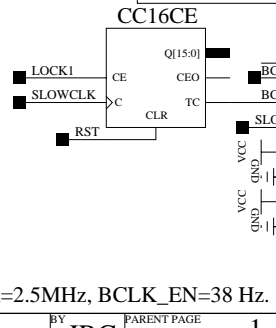
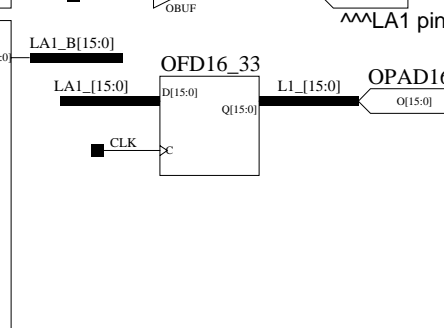
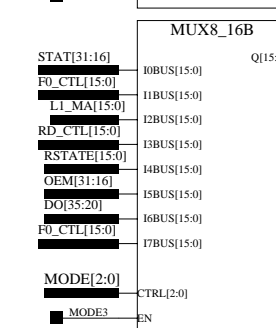
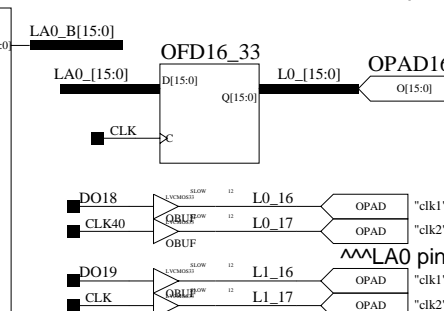
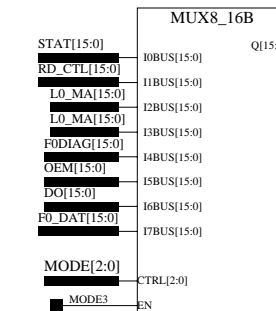
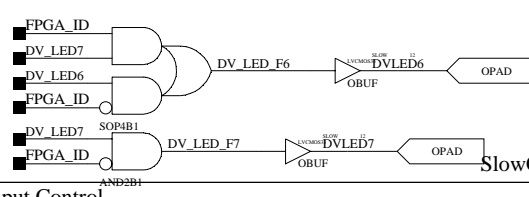
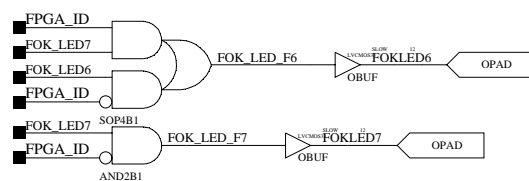
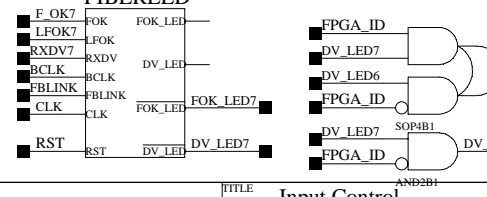
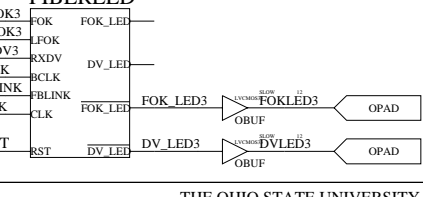
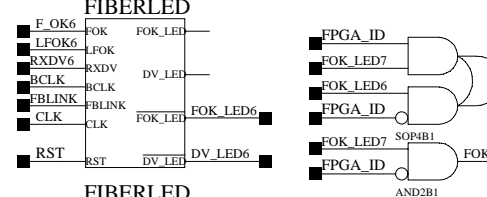
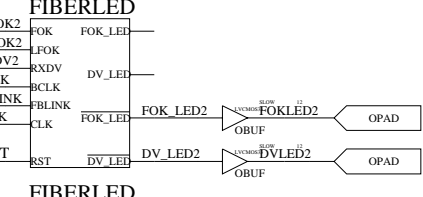
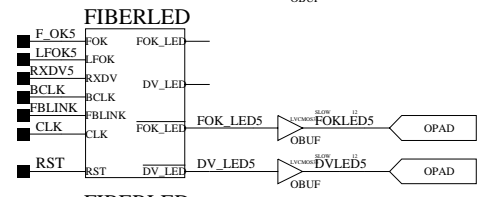
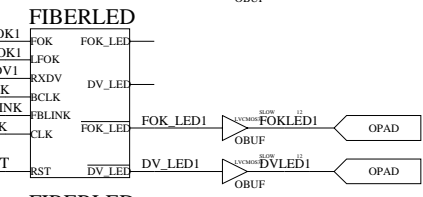
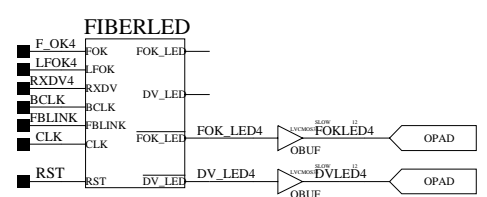
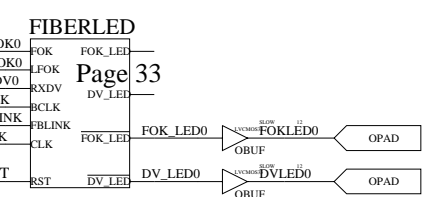
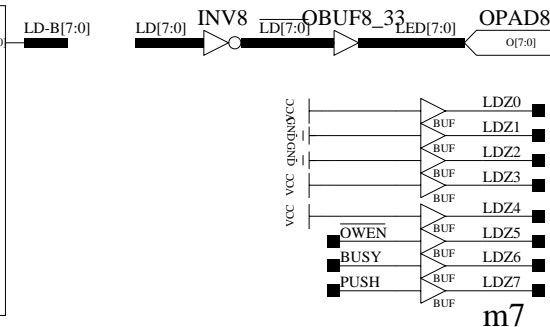
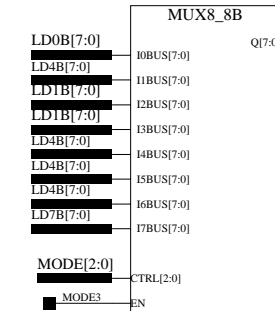
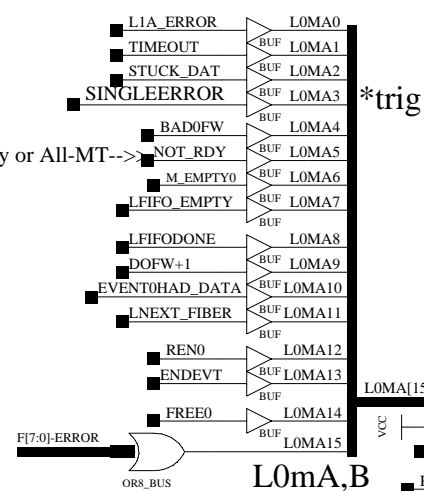
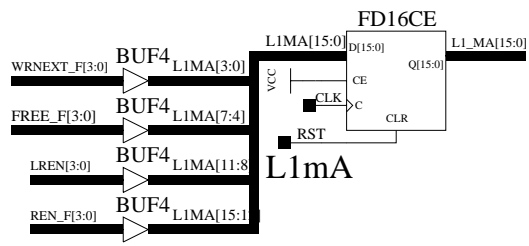

SlowCLK=2.5MHz, BCLK_EN=38 Hz. Shift 13 will give ~1.5Hz BCLK, Shift 5 gives ~4Hz.

FIFO_AF & FIFO_FULL are driven by Tbufs from 22 mem's.
 NEW_ENB & NEW_MEM are driven by MemCtrl.
 TX_EN & DIN are driven by DDU_Ctrl FPGA.
 REN is driven by RD_CTRL.
 IDLEOUT needs local control logic.

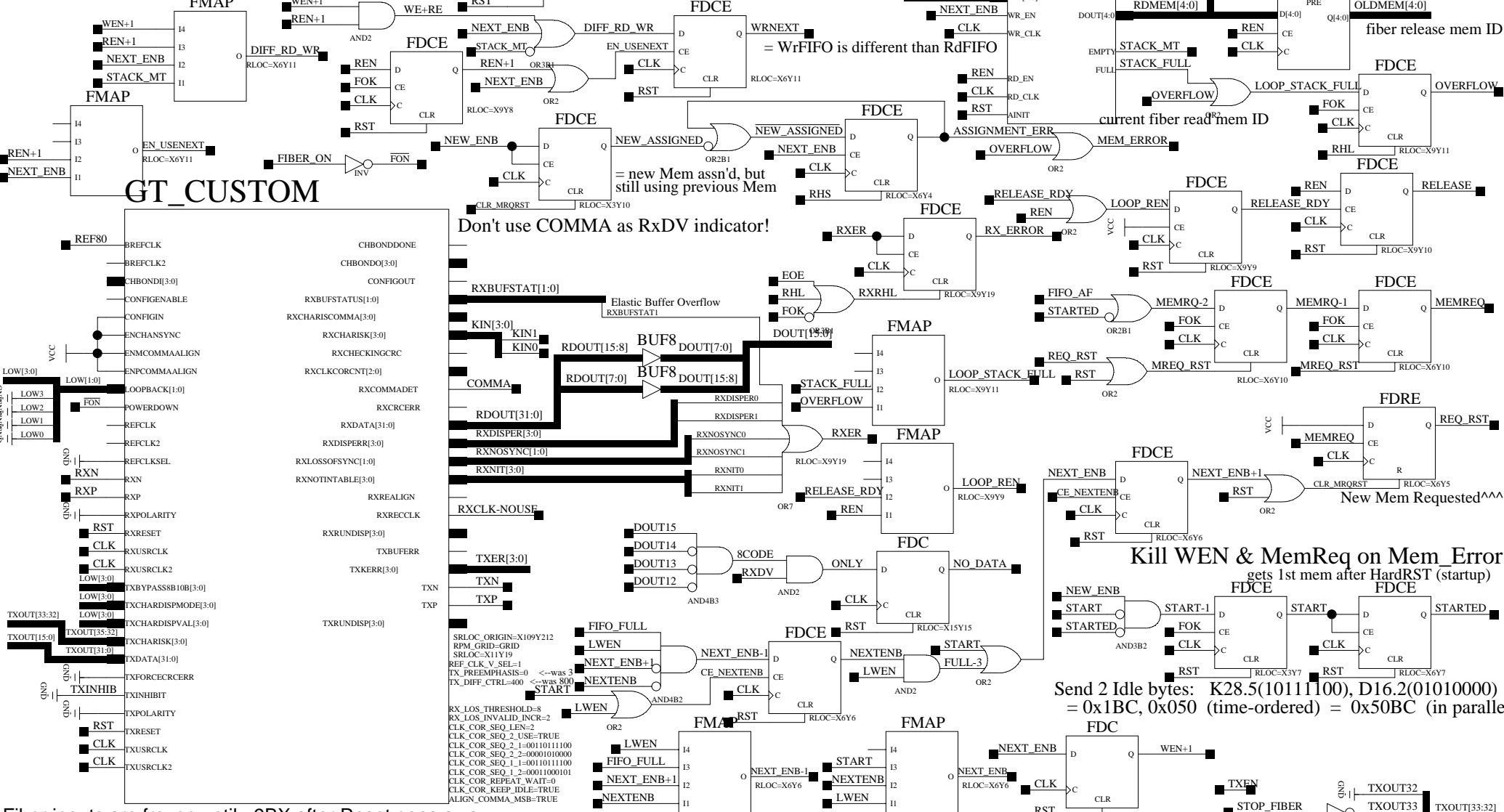

Fiber inputs are frozen until ~9BX after Reset goes away

THE OHIO STATE UNIVERSITY PHYSICS DEPARTMENT ELECTRONICS LAB 174 WEST 18TH AVE. COLUMBUS OH 43210	TITLE Input Unit DDU Input Controller Logic CMS CSC Electronics	BY JRG DATE 4-23-2009_16:56	PARENT PAGE 2 PROJECT FILE IN_UNIT .1	D785D PAGE 3
---	--	--------------------------------------	---	--------------------

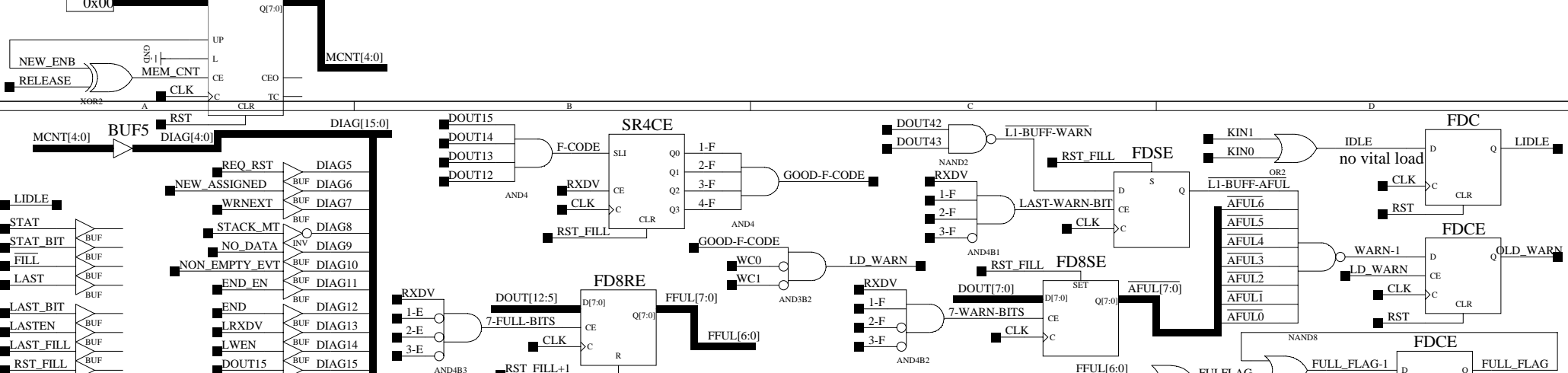

LAST Flag is insensitive to single-bit errors

LAST Flag Logic tables, checks for E-Codes in DMB Data (L means LAST Flag will be set for that word)

BRAM FIFO Output

Assume 4 E-Codes at DMB End are sequential with no gaps

Normal event sync:	X	X
	X	X
<hr/>		
	E _L	E
	E	E
<hr/>		
Normal, but lose 1st E-Word: (or lose last E-Word)	X	X
	X	X
<hr/>		
	E _L	E _L
	Fill	E
<hr/>		
Normal, but lose 2nd E-Word: (or lose 3rd E-Word)	X	X
	X	X
<hr/>		
	E _L	E
	Fill	E
<hr/>		
Normal, but BAD 1st E-Code:	X	X
	X	X
<hr/>		
	E _L	X
	E	E
<hr/>		
Normal, but BAD 2nd E-Code:	X	X
	X	X
<hr/>		
	X _L	E
	E	E
<hr/>		
BAD 3rd or 4th E-Code is no problem		

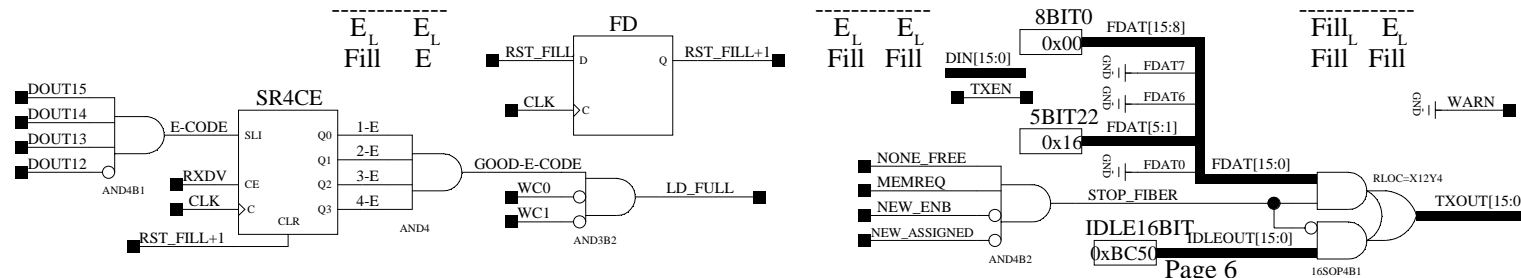

Set LAST Flag for Bad 2nd E-Code case

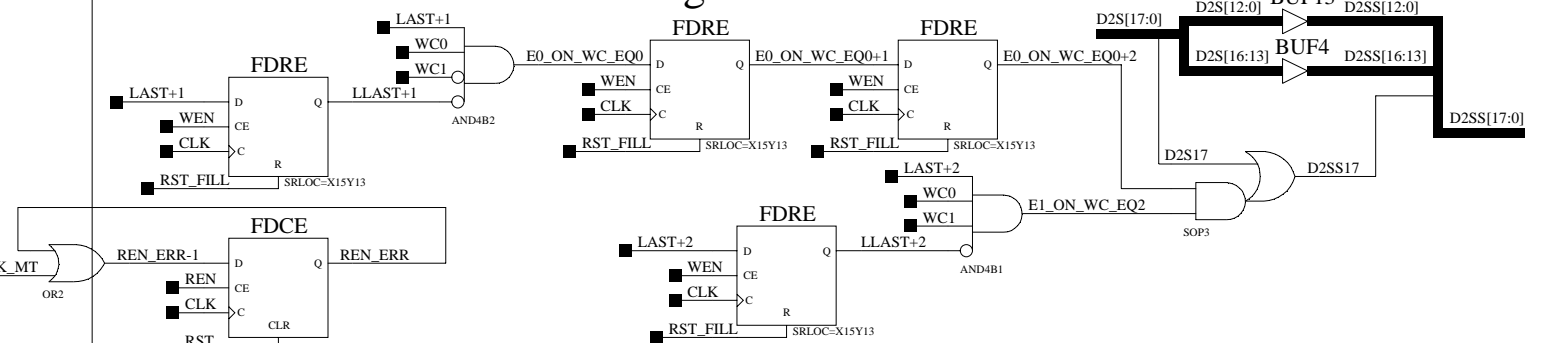

Page 6

FIFO_AF & FIFO_FULL are driven by Tbufs from 22 mem's.
 NEW_ENB & NEW_MEM are driven by MemCtrl.
 TX_EN & DIN are driven by DDU_Ctrl FPGA.
 REN is driven by RD_CTRL.
 IDLEOUT needs local control logic.

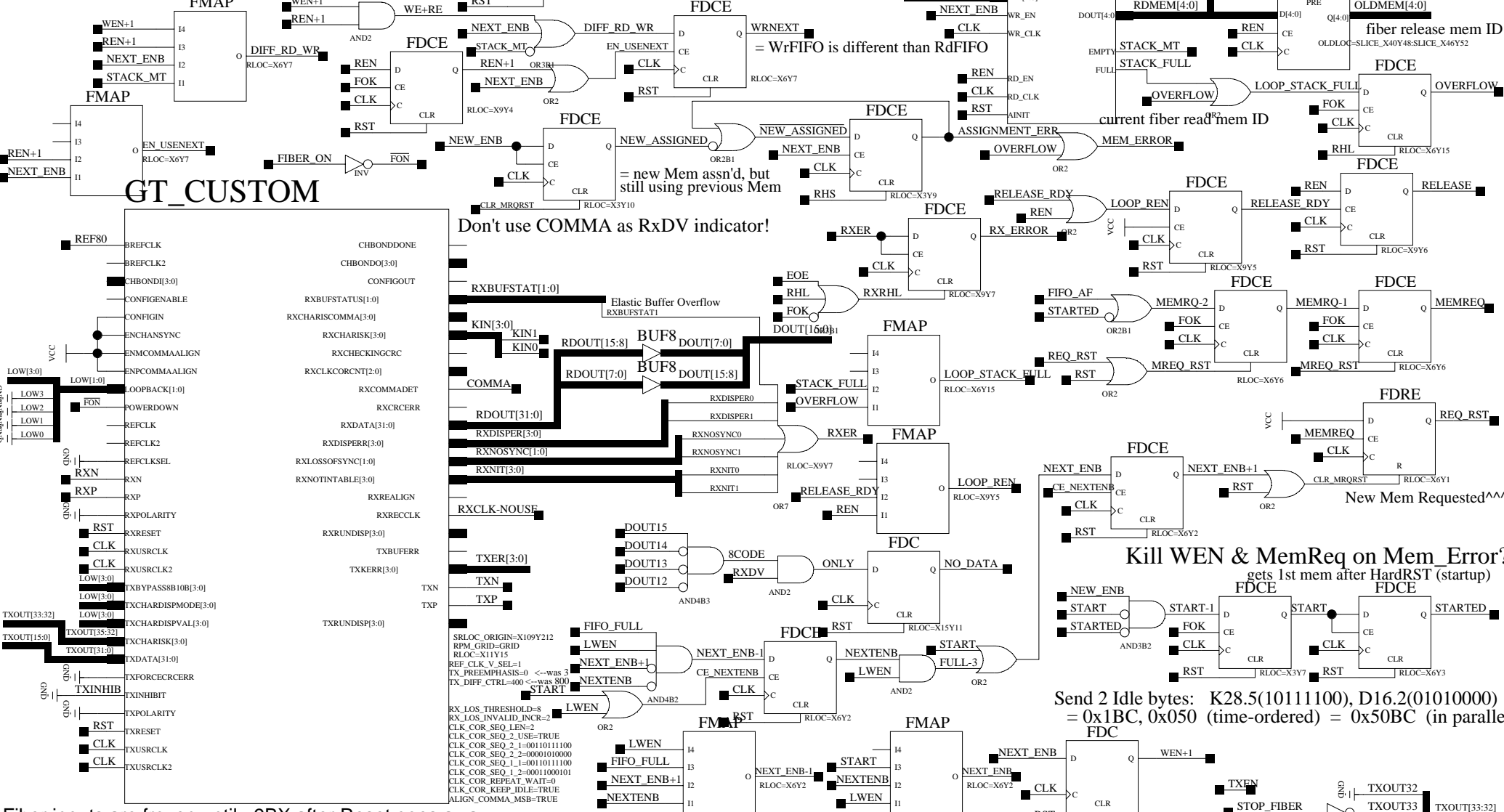

Fiber inputs are frozen until ~9BX after Reset goes away

FILL Logic for 2-4 word alignment

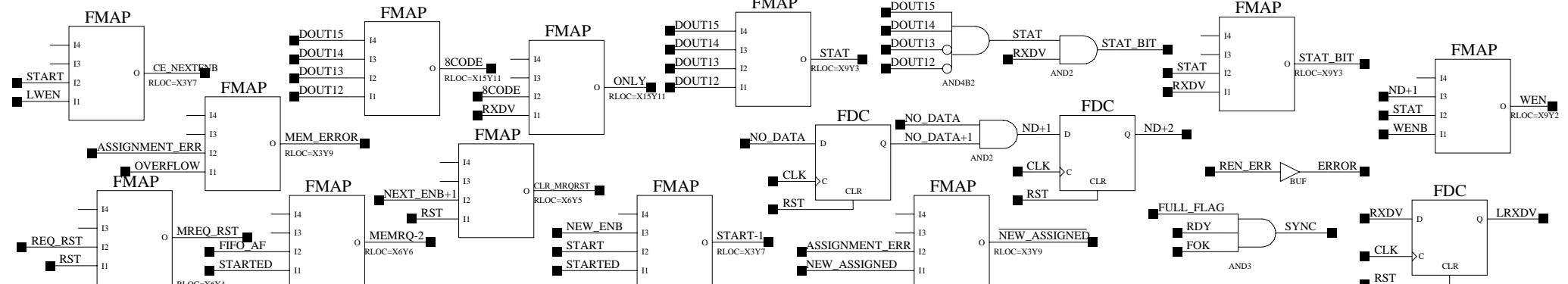
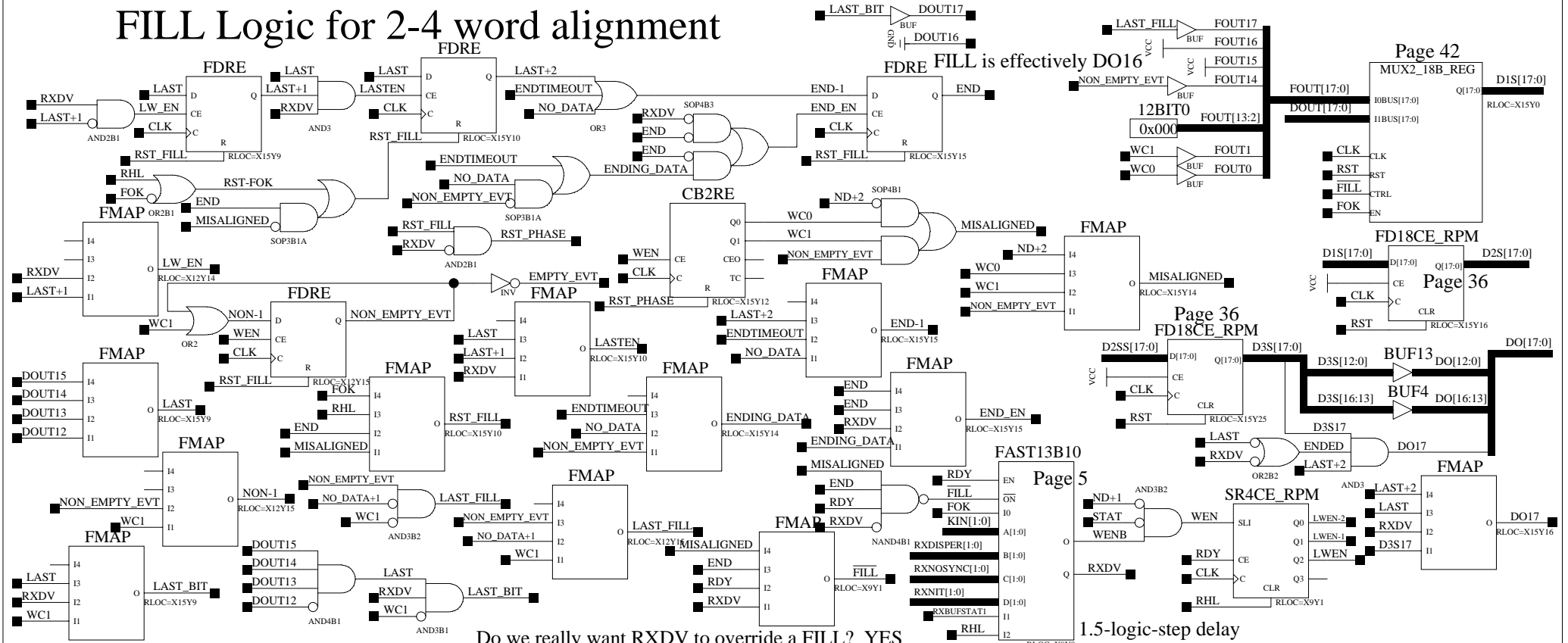

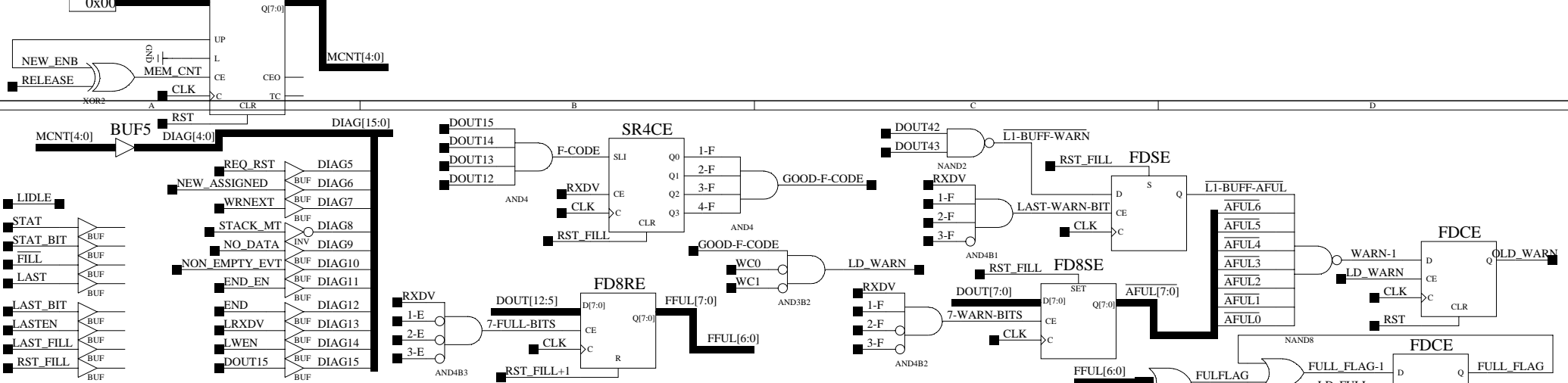

LAST Flag is insensitive to single-bit errors

LAST Flag Logic tables, checks for E-Codes in DMB Data (L means LAST Flag will be set for that word)

BRAM FIFO Output

Assume 4 E-Codes at DMB End are sequential with no gaps

Normal event sync:	X	X
	X	X
<hr/>		
	E _L	E
	E	E
<hr/>		
Normal, but lose 1st E-Word:	X	X
(or lose last E-Word)	X	X
<hr/>		
	E _L	E _L
	Fill	E
<hr/>		
Normal, but lose 2nd E-Word:	X	X
(or lose 3rd E-Word)	X	X
<hr/>		
	E _L	E
	Fill	E
<hr/>		
Normal, but BAD 1st E-Code:	X	X
	X	X
<hr/>		
	E _L	X
	E	E
<hr/>		
Normal, but BAD 2nd E-Code:	X	X
	X	X
<hr/>		
	X _L	E
	E	E
<hr/>		
BAD 3rd or 4th E-Code is no problem		

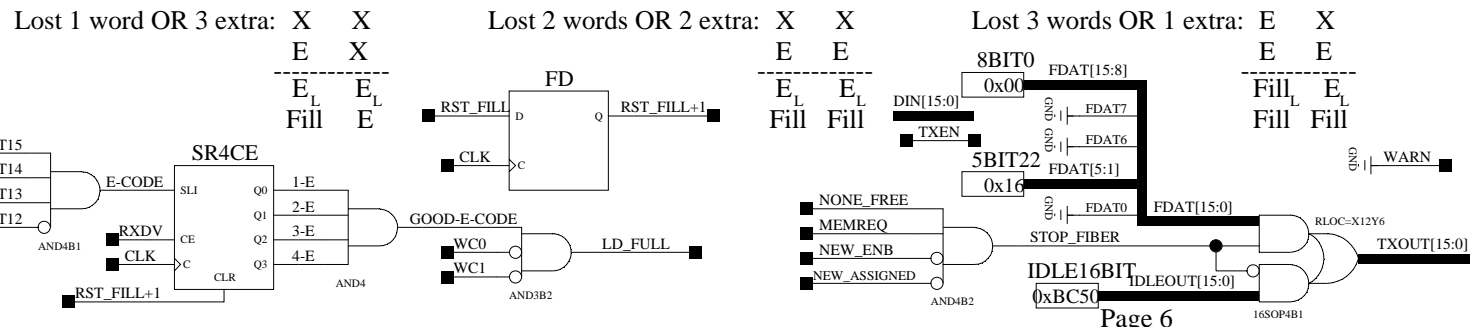

Set LAST Flag for Bad 2nd E-Code case

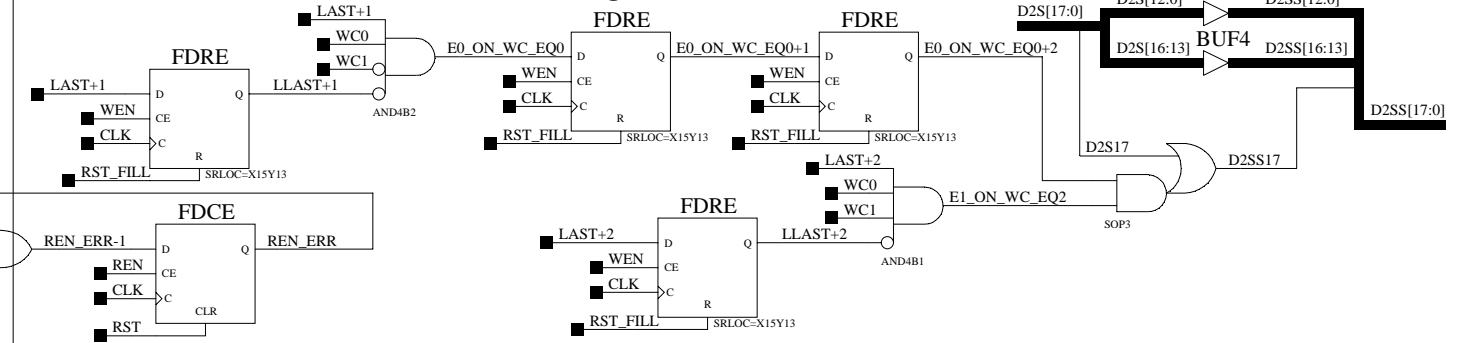

Page 6

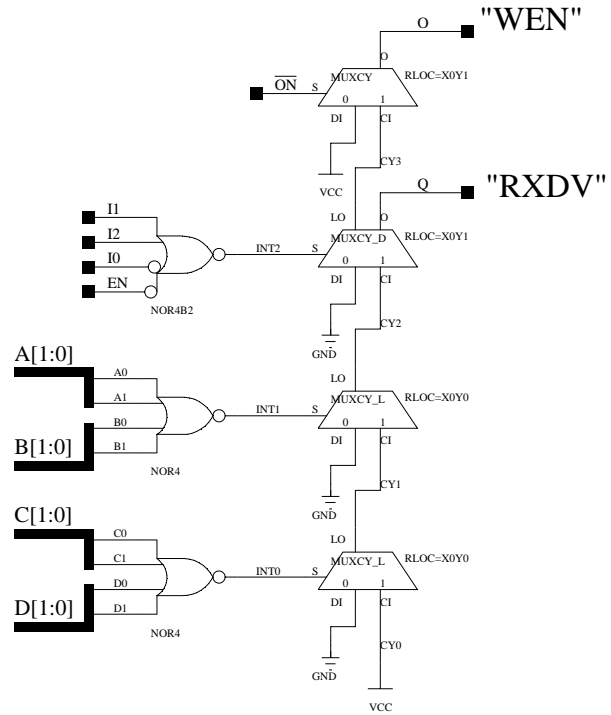
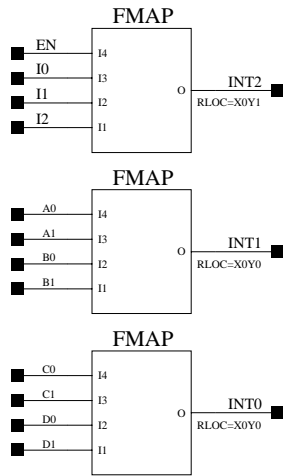

JRG

Title:	FAST13B10	
Comments:	Custom Logic for DDU similar to: AND12B10 with an OR2 (allows ON to override)	
Date:	19th December 2003	Ver: 1
Sheet Size:	B	Rev: A

Send 2 Idle bytes:

K28.5(10111100)+D16.2(01010000)
= 0x1BC + 0x050 (time-ordered)
= 0xBC50 (in parallel)

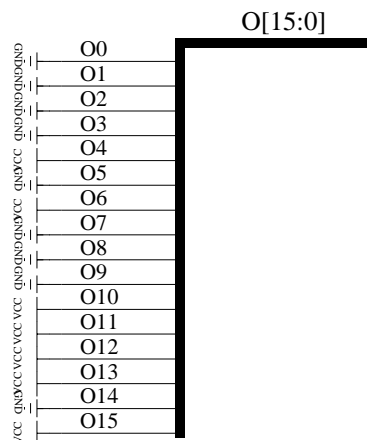

Corner 0 FIFO usage

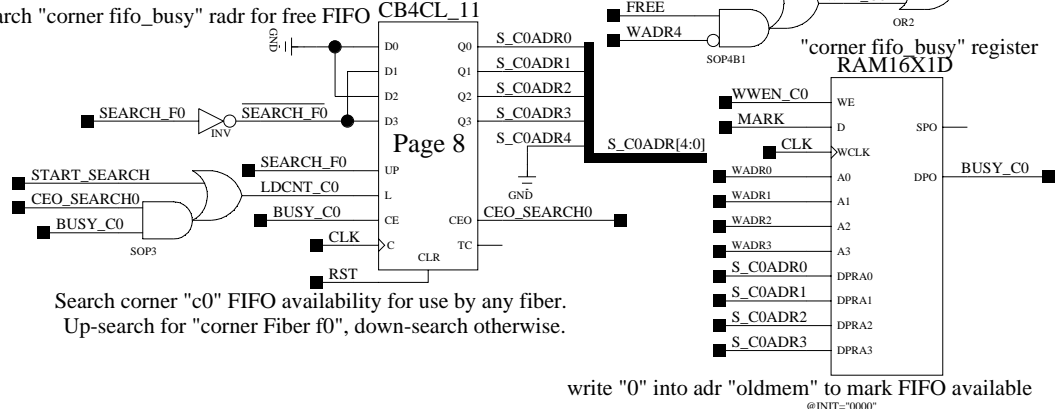

Search corner "c0" FIFO availability for use by any fiber.
Up-search for "corner Fiber f0", down-search otherwise.

Which Fibers need a new FIFO?

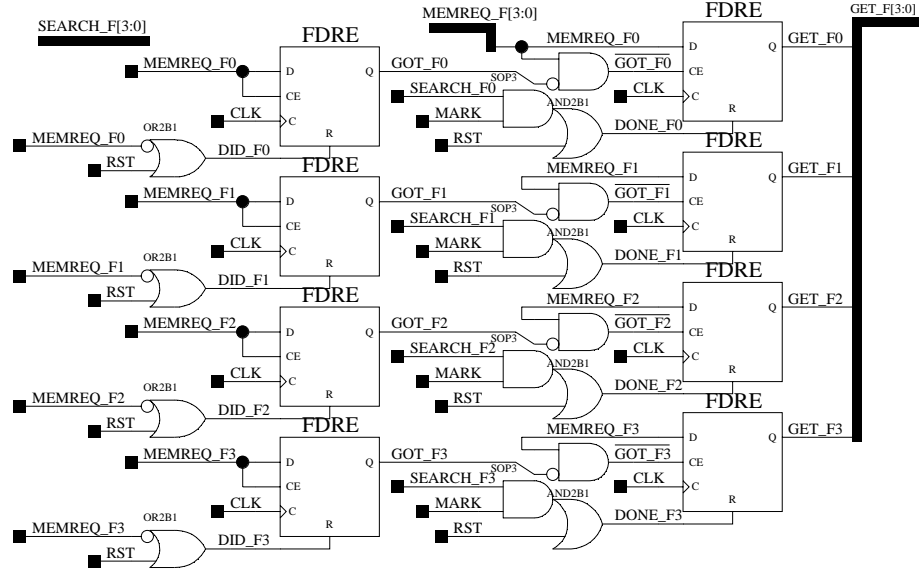

FIFO Release Control

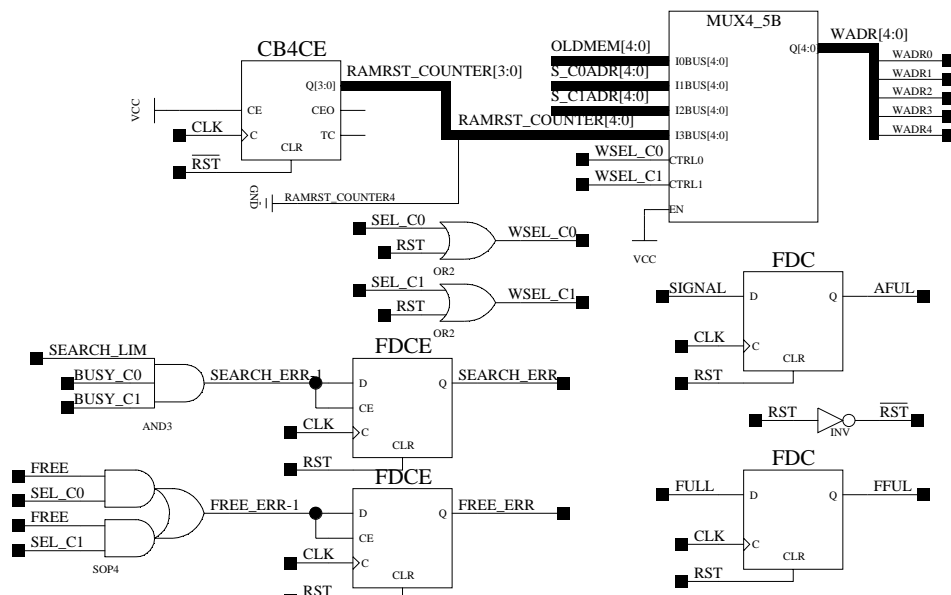
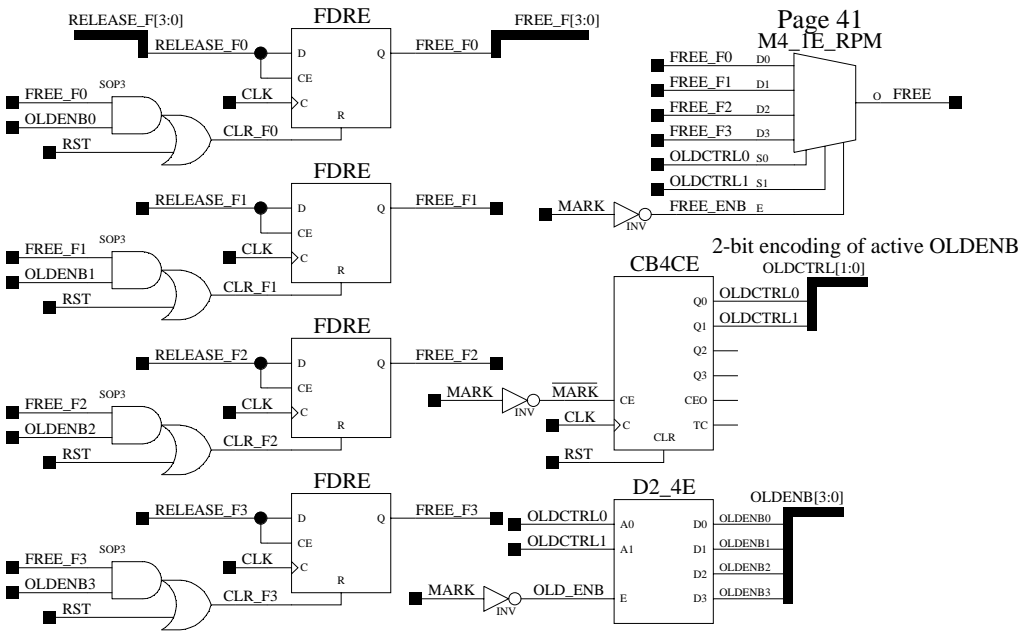

Corner 1 FIFO usage

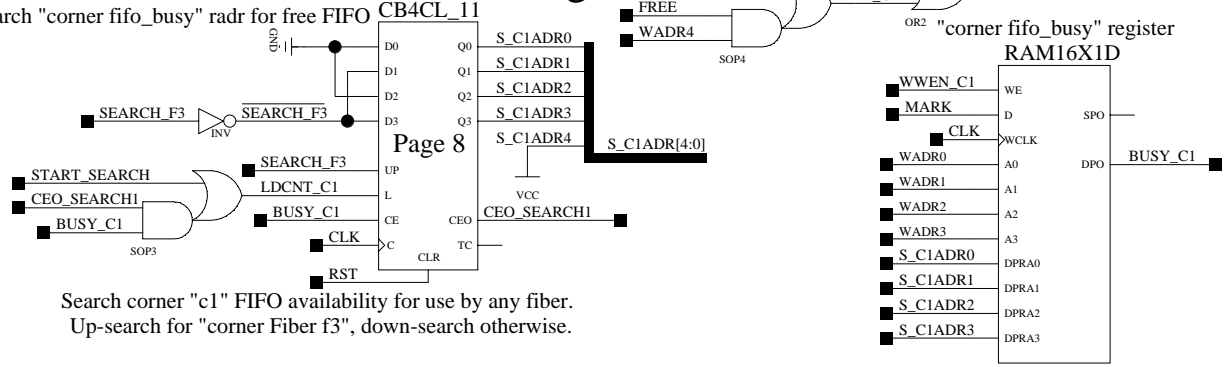

Search corner "c1" FIFO availability for use by any fiber.
Up-search for "corner Fiber f3", down-search otherwise.

@INIT="0000"
write "0" into adr "oldmem" to mark FIFO available

Assign Fiber to FIFO & Assign FIFO to Fiber

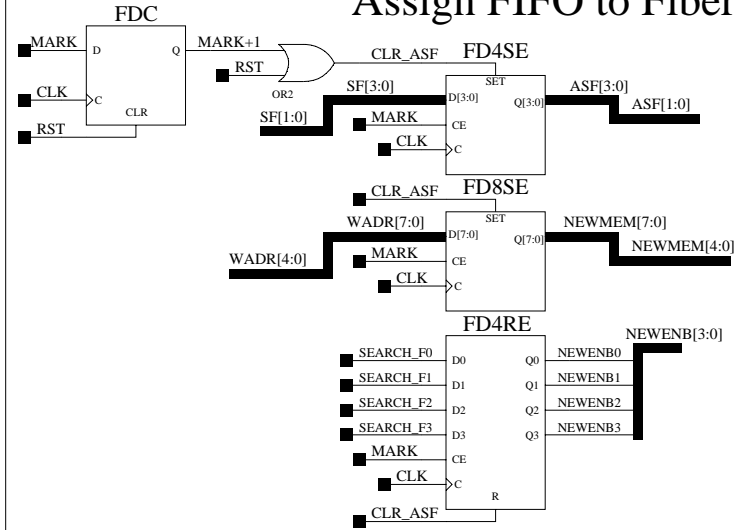

FIFO Assign Control

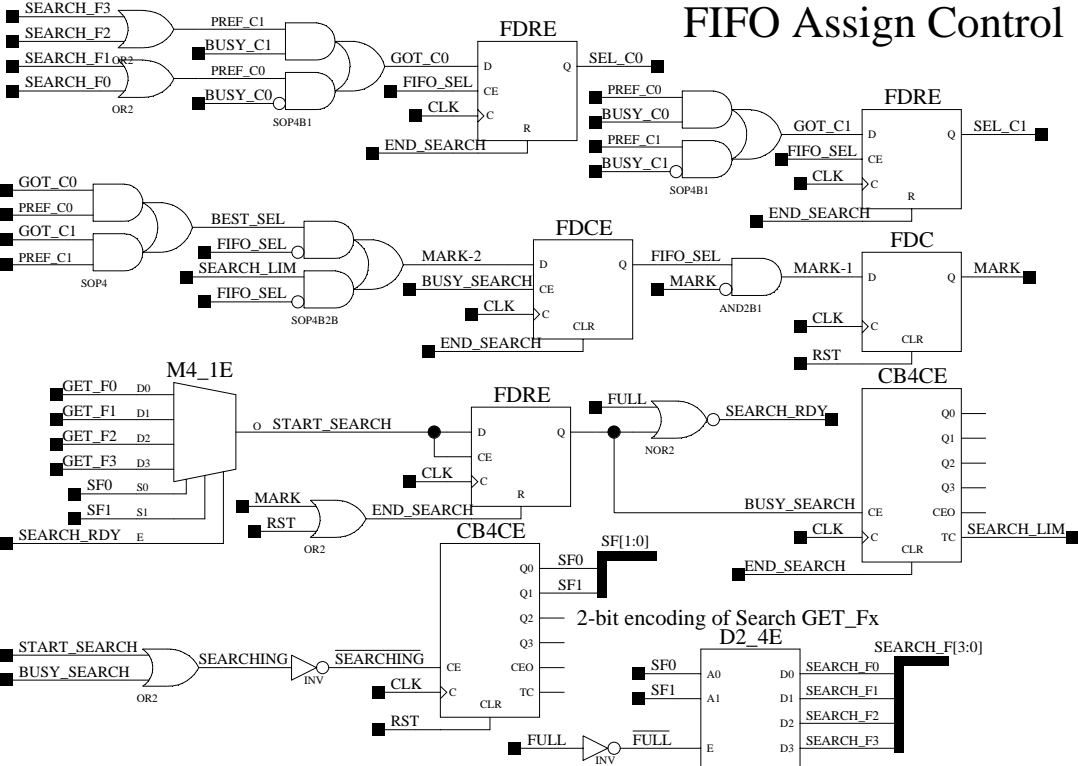

PREF_C[1:0]
BUSY_C[1:0]
GOT_C[1:0]

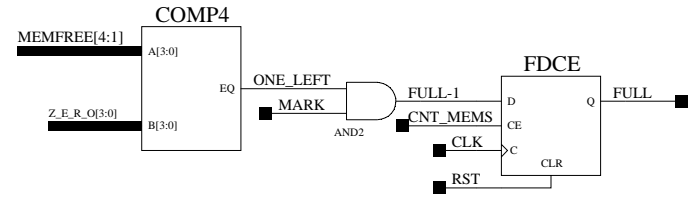

How many of 22 FIFOs are free?

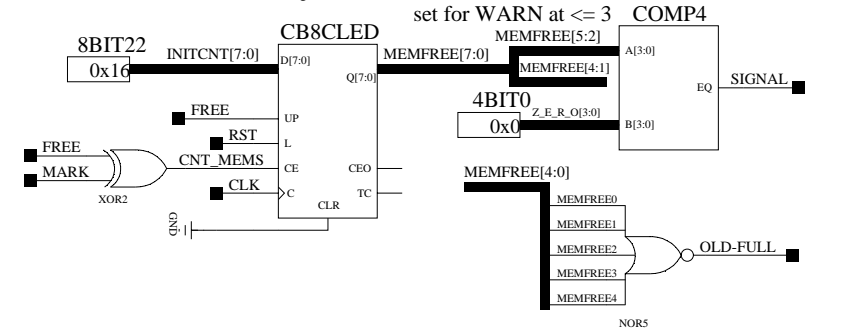

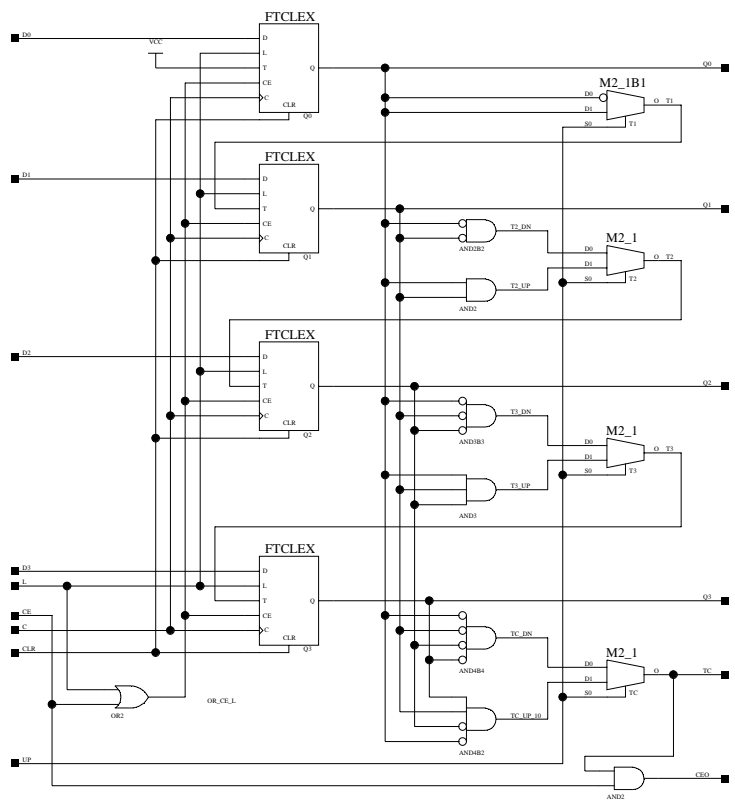

FNEXT, FWEN & FxDIN come from the 4 InUnits.
 ASF & ASF_ADR come from MemCtrl.
 FAD is the fixed FIFO location reference.

Write Control

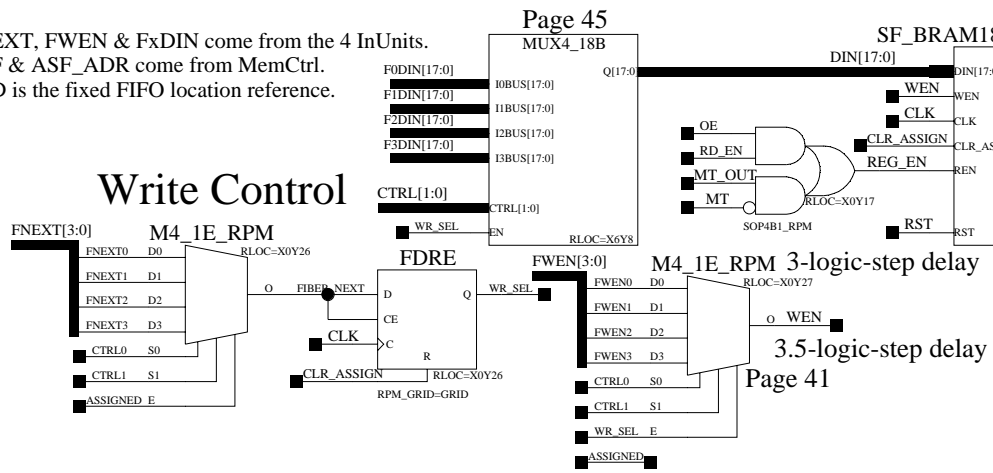

MemIn-MemOut Mapping:

DO35	Dout35
DO34	Dout17
DO33-26	Dout34-27
DO25-18	Dout16-9
DO17	Dout26
DO16	Dout8
DO15-8	Dout25-18
Din7-0	Dout7-0

MT == less than 36-bits of data are available

First Word Fall Through logic:

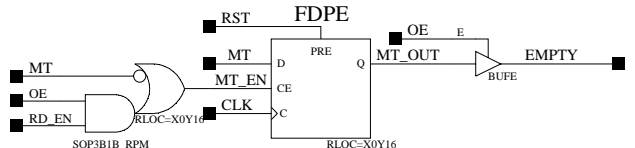
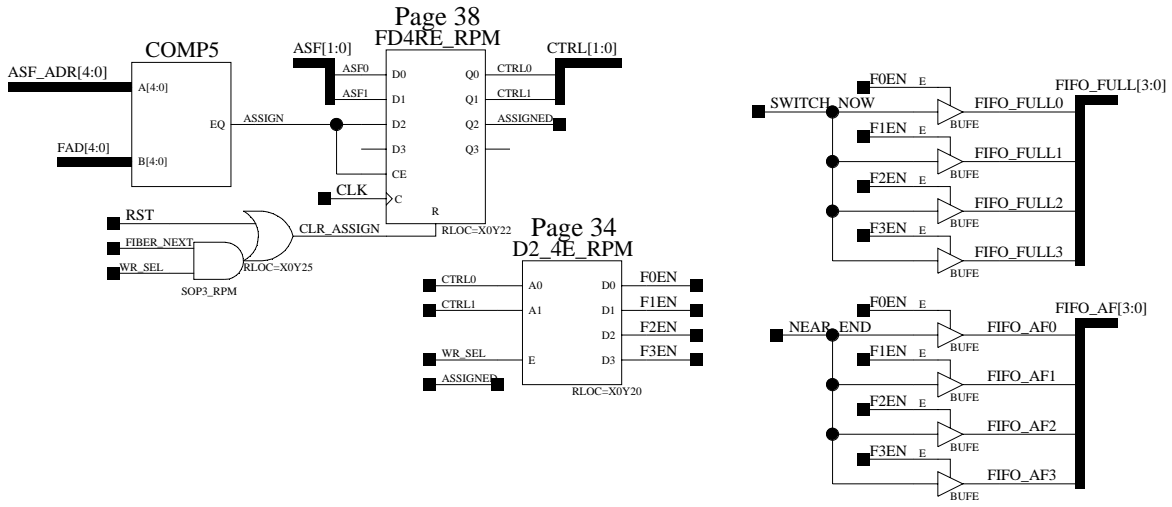

Not Used: REN = OE * RD_EN

FNEXT, FWEN & FxDIN come from the 4 InUnits.
 ASF & ASF_ADR come from MemCtrl.
 FAD is the fixed FIFO location reference.

Write Control

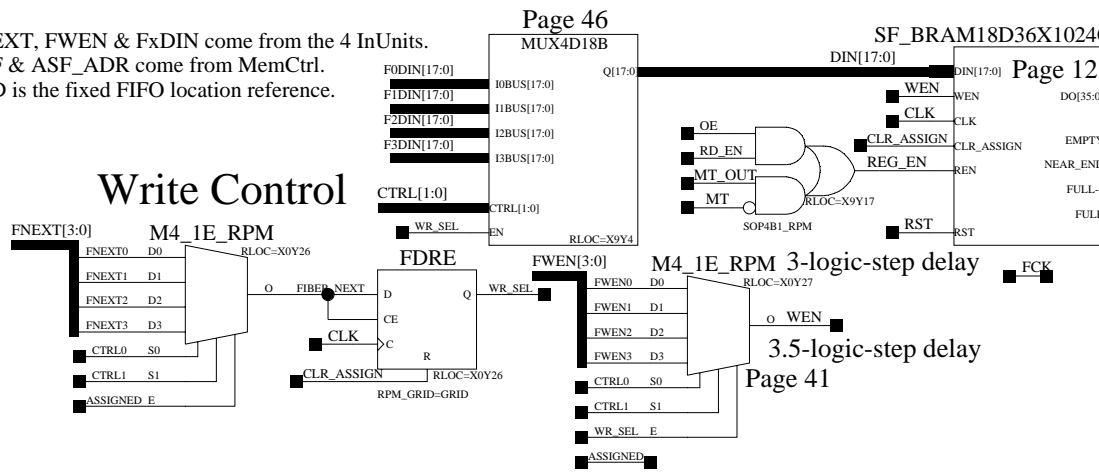

Page 12

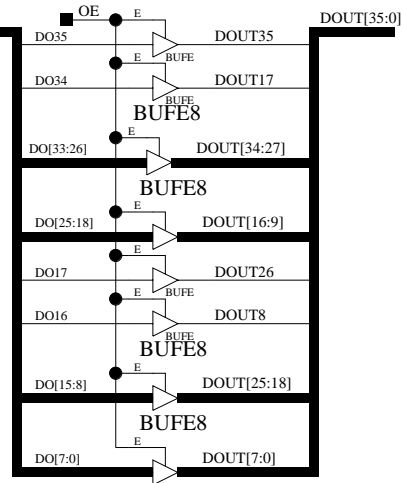

MemIn-MemOut Mapping:

DO35	Dout35
DO34	Dout17
DO33-26	Dout34-27
DO25-18	Dout16-9
DO17	Dout26
DO16	Dout8
DO15-8	Dout25-18
Din7-0	Dout7-0

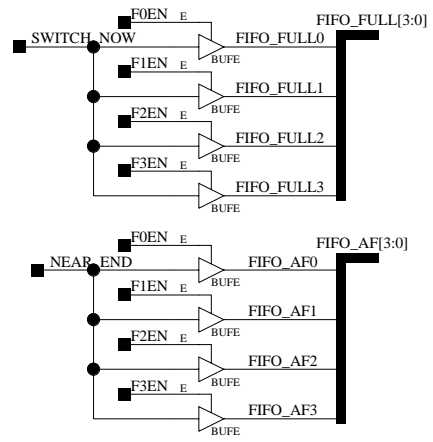
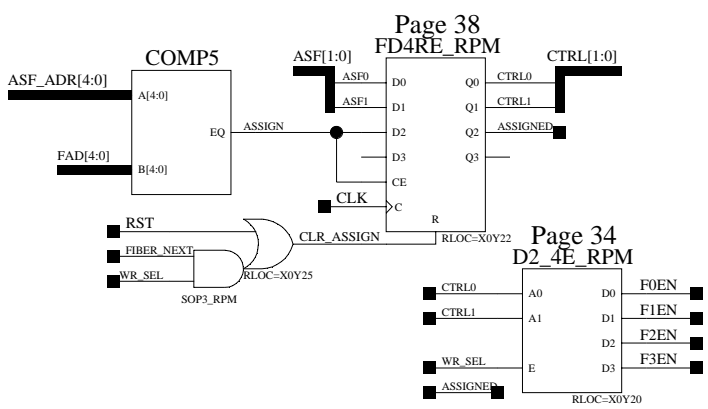

First Word Fall Through logic:

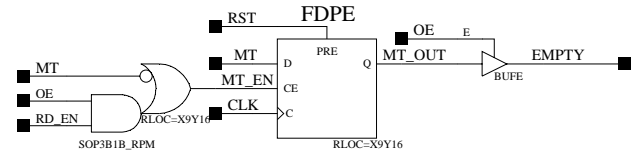

Not Used: REN = OE * RD_EN

sfifo18_36x1024

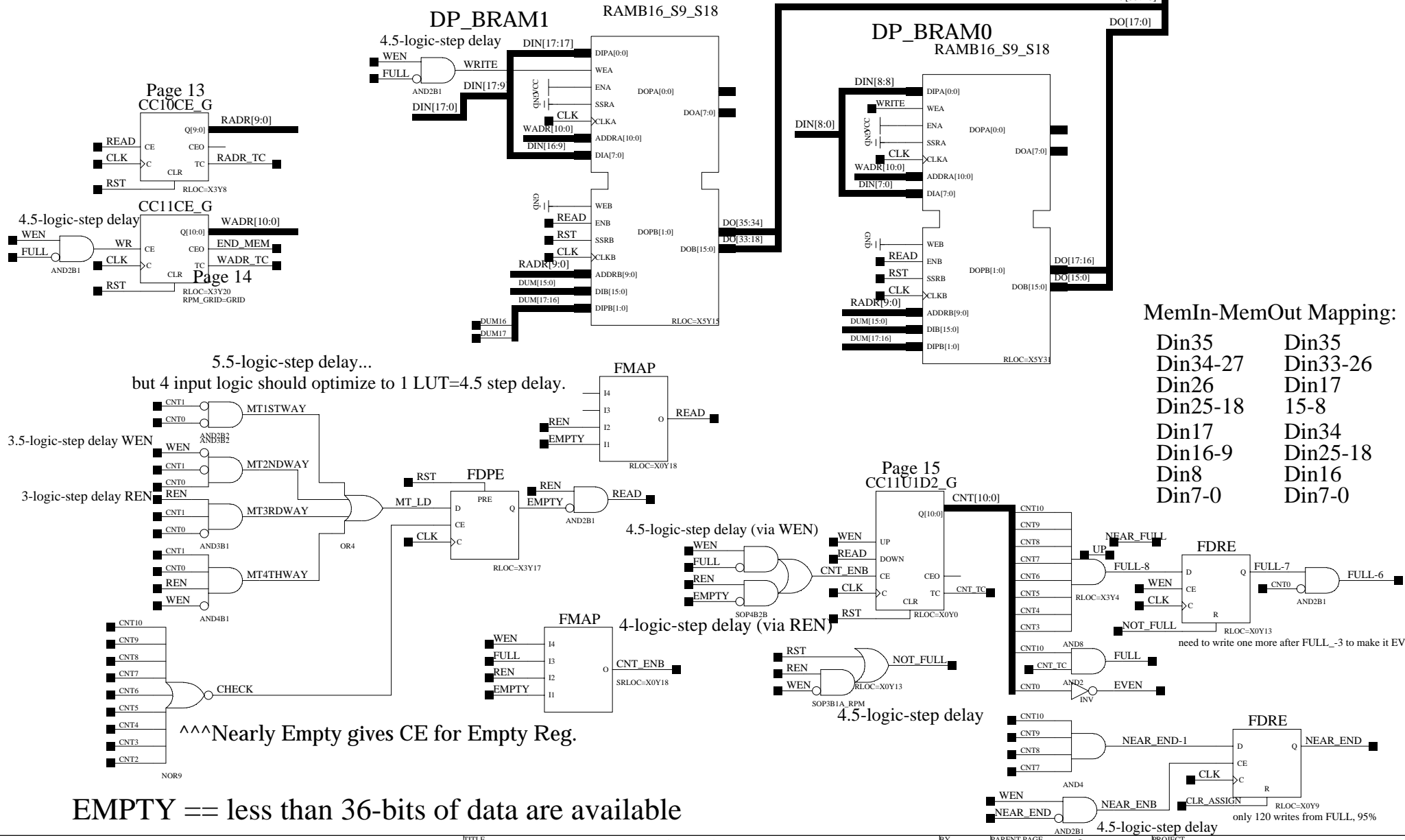

MemIn-MemOut Mapping:

Din35	Din35
Din34-27	Din33-26
Din26	Din17
Din25-18	15-8
Din17	Din34
Din16-9	Din25-18
Din8	Din16
Din7-0	Din7-0

EMPTY == less than 36-bits of data are available

sfifo18_36x1024_diagonal

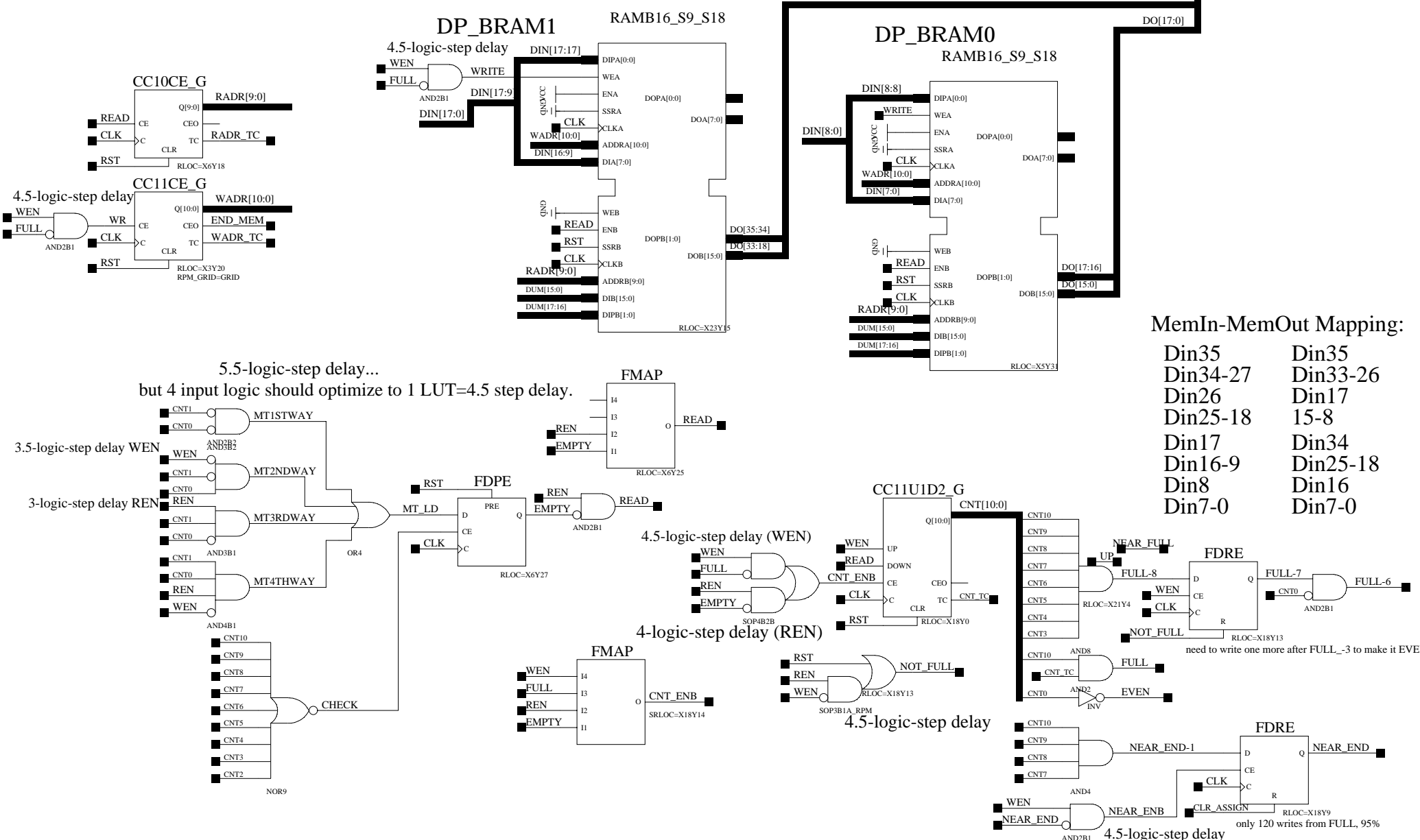

MemIn-MemOut Mapping:

Din35	Din35
Din34-27	Din33-26
Din26	Din17
Din25-18	15-8
Din17	Din34
Din16-9	Din25-18
Din8	Din16
Din7-0	Din7-0

5.5-logic-step delay...
but 4 input logic should optimize to 1 LUT=4.5 step delay.

3.5-logic-step delay WEN

3-logic-step delay REN

4.5-logic-step delay (WEN)

4-logic-step delay (REN)

4.5-logic-step delay

4.5-logic-step delay

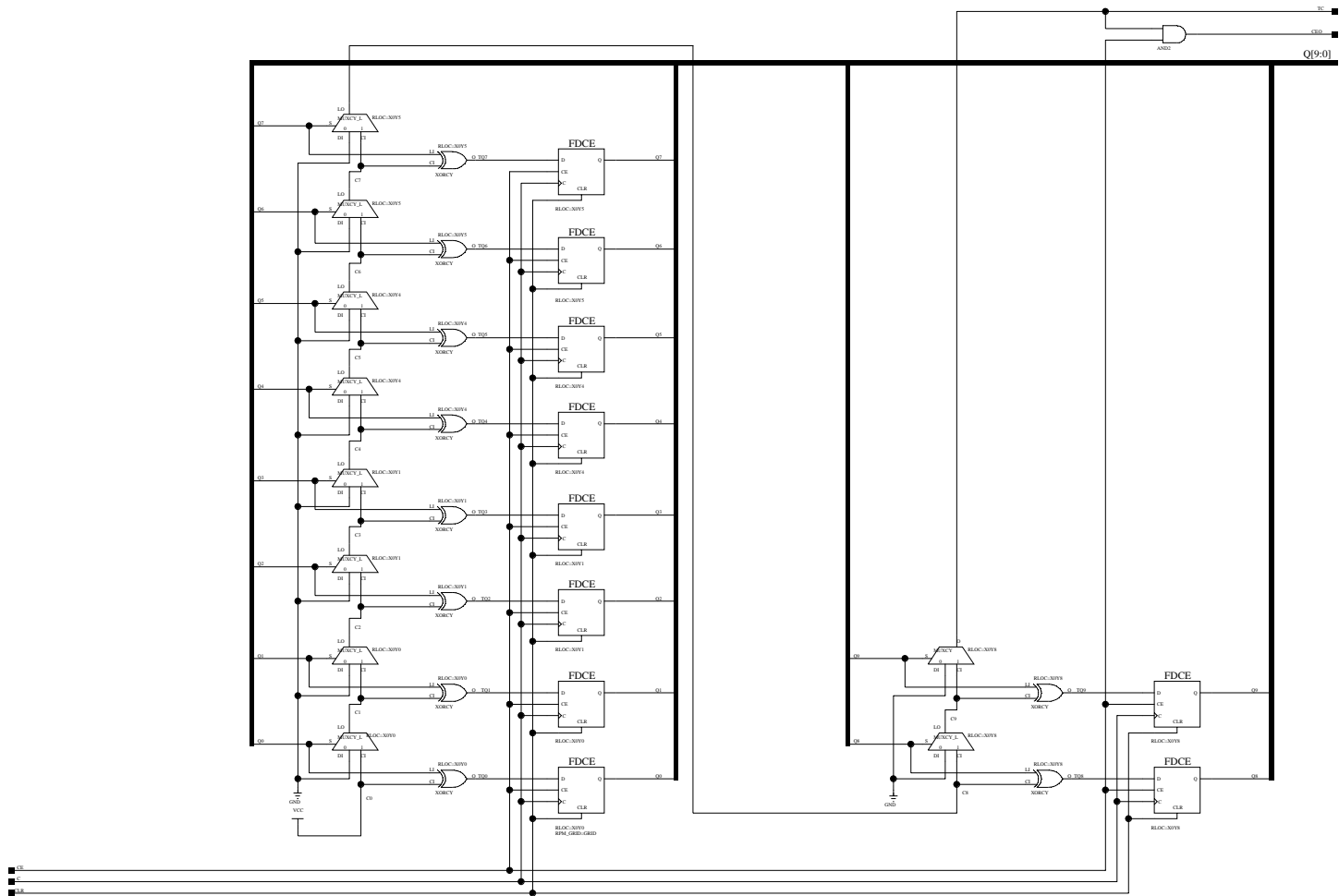

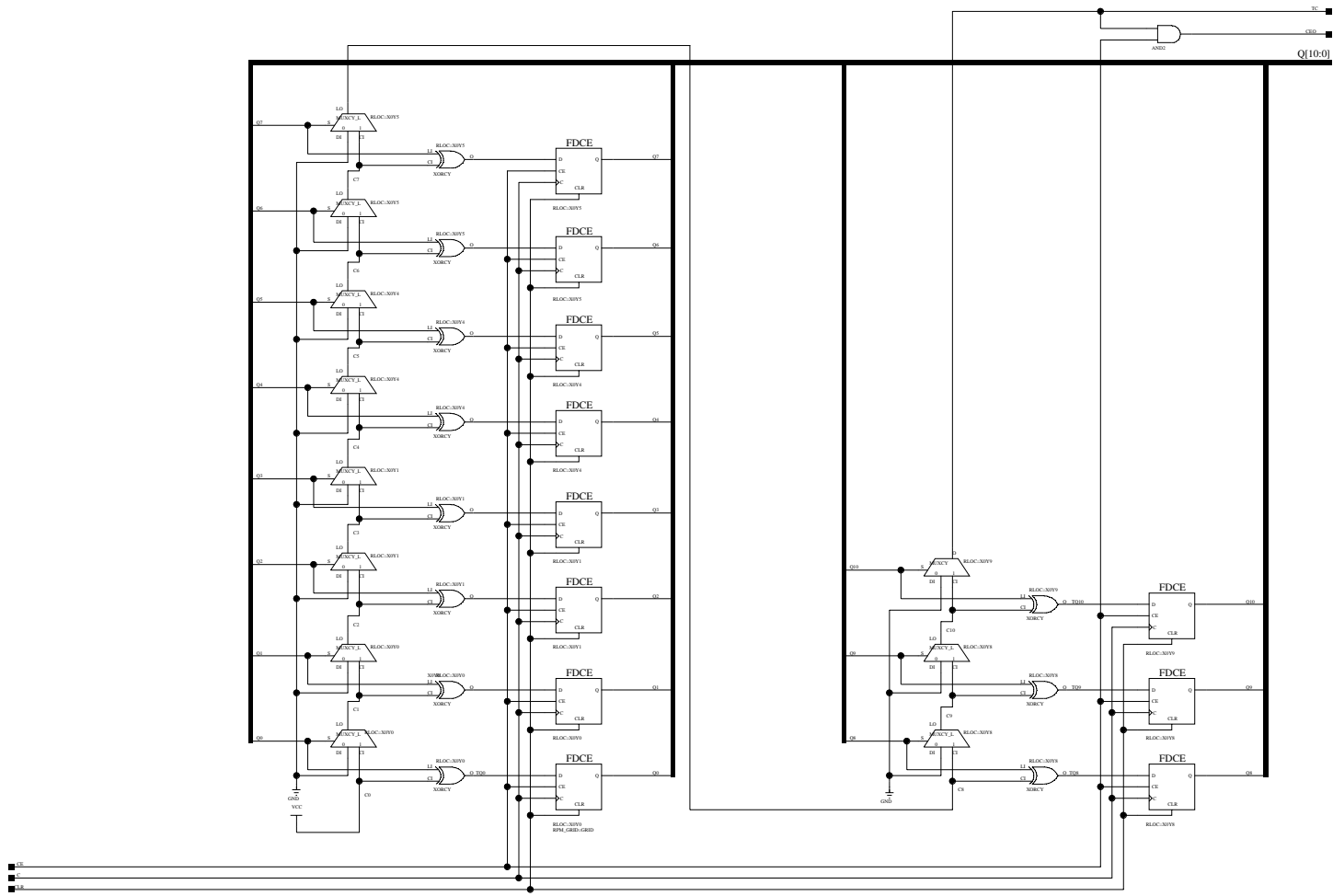

■ CE
 ■ E0
 ■ E8

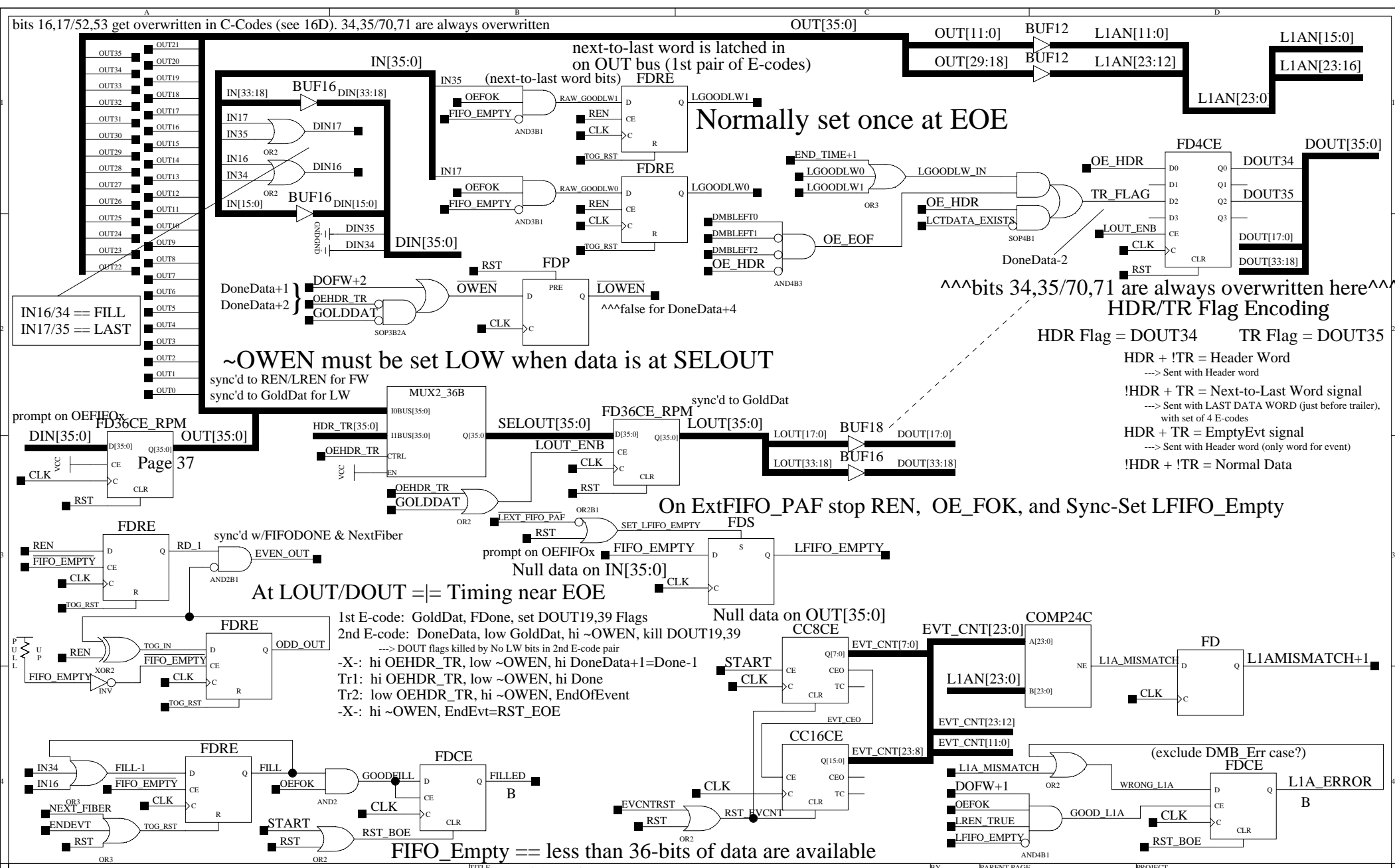

HDR/TR Flag Encoding

HDR Flag = DOUT34 TR Flag = DOUT35

HDR + !TR = Header Word
 --> Sent with Header word

!HDR + TR = Next-to-Last Word signal
 --> Sent with LAST DATA WORD (just before trailer), with set of 4 E-codes

HDR + TR = EmptyEvt signal
 --> Sent with Header word (only word for event)

!HDR + !TR = Normal Data

3 more words to FIFO after FF is set; use LEXT_FIFO_PAF to stop REN/OWEN!

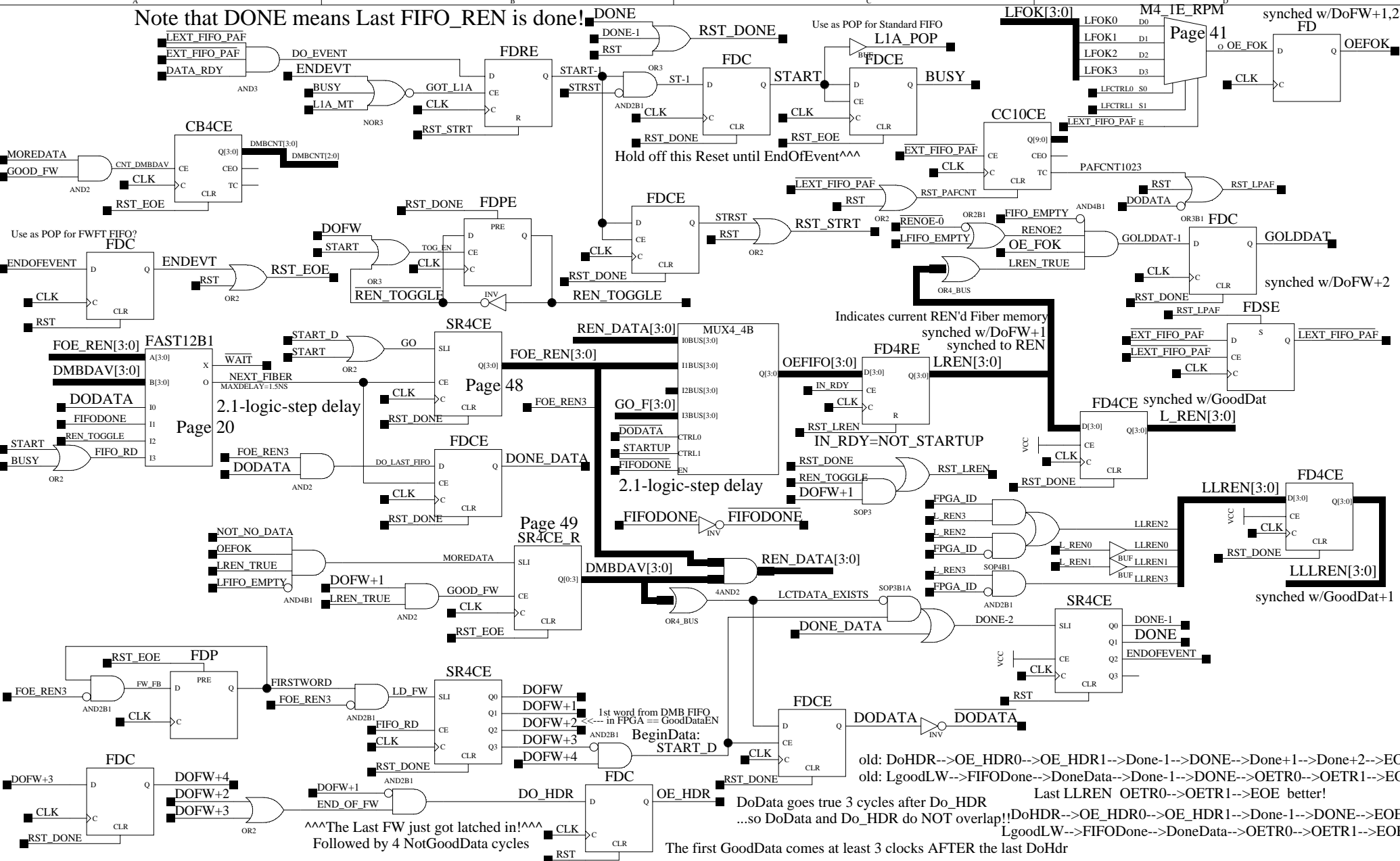

Check for DMB Error Word and consistency:

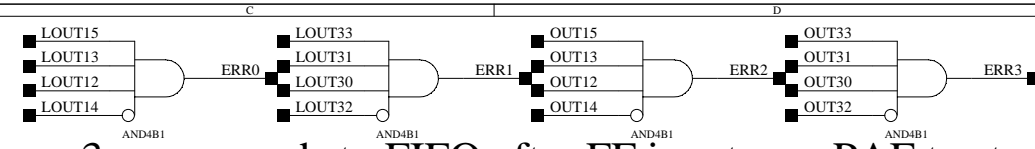
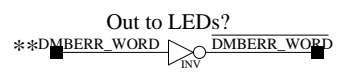
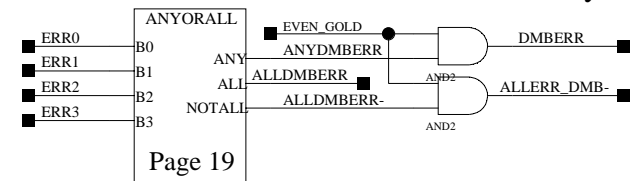

3 more words to FIFO after FF is set; use PAF to stop

Check consistency of the four "Special Word" bits:

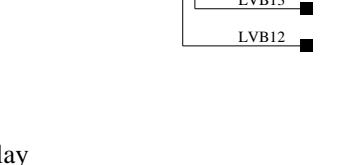
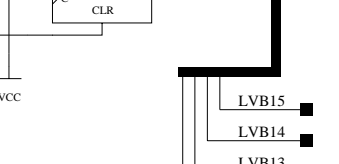
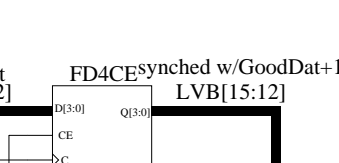
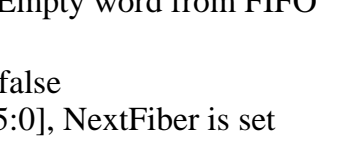
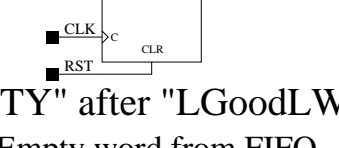
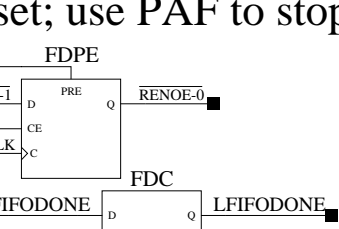
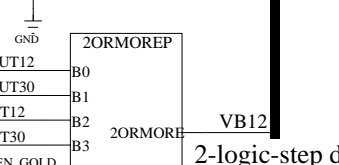
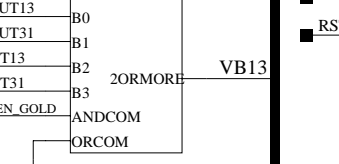
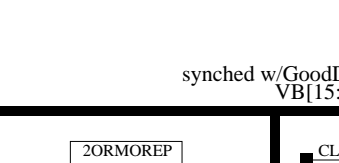
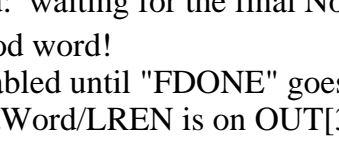
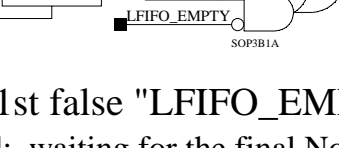
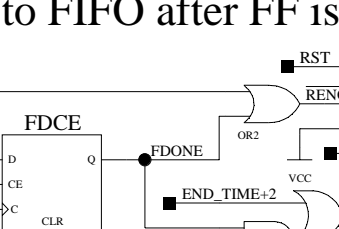
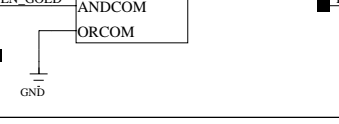
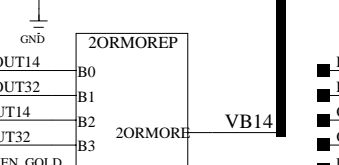
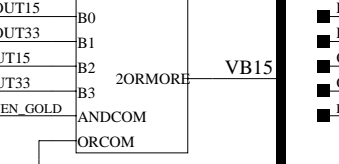
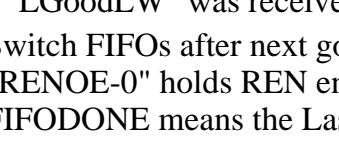
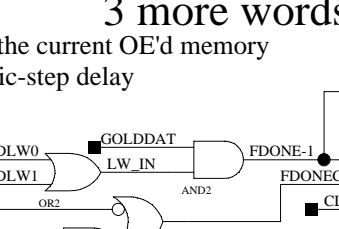
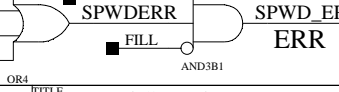
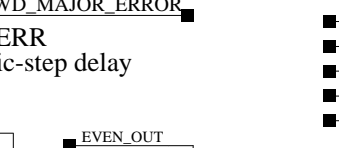
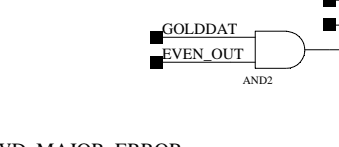
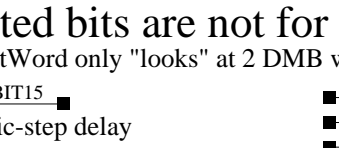
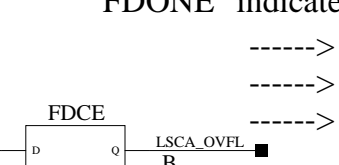
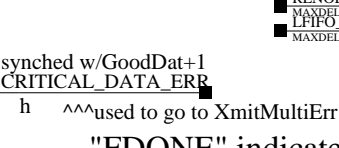
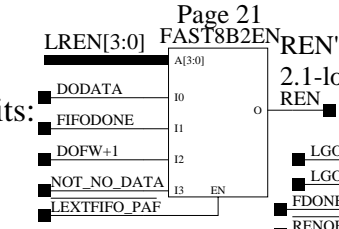
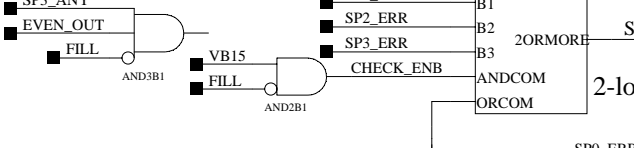
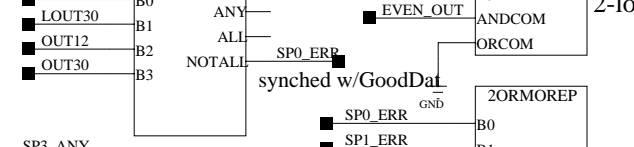
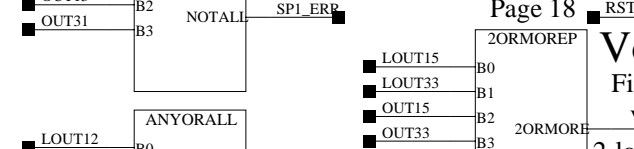
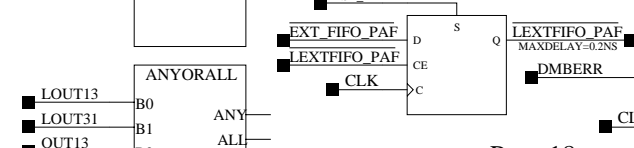
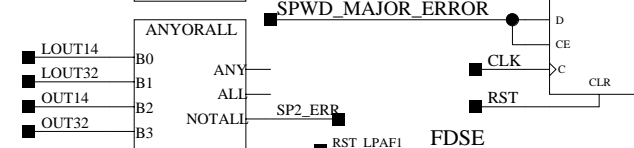
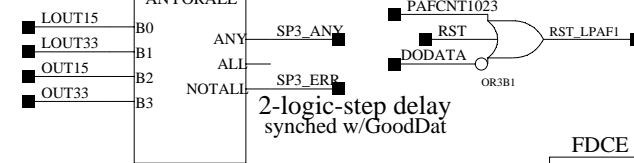

Page 21

REN's the current OE'd memory
2.1-logic-step delay

REN

REN

REN

REN

REN

REN

A FIFO ends at 1st false "LFIFO_EMPTY" after "LGoodLW"

"FDONE" indicates "LGoodLW" was received: waiting for the final NotEmpty word from FIFO

-----> Switch FIFOs after next good word!

-----> "RENOE-0" holds REN enabled until "FDONE" goes false

-----> FIFODONE means the LastWord/LREN is on OUT[35:0], NextFiber is set

Voted bits are not for FirstWord use!

FirstWord only "looks" at 2 DMB words

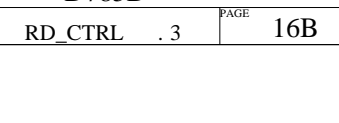
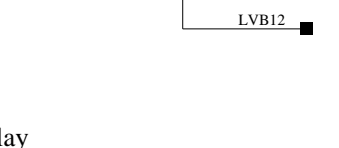
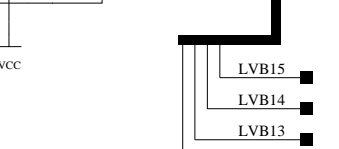
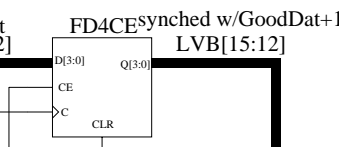
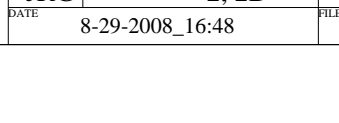
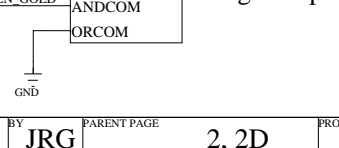
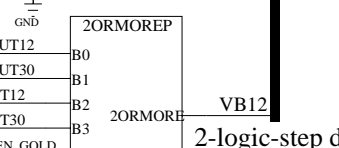
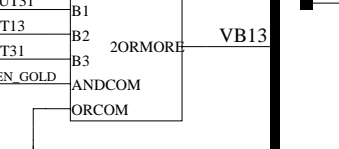
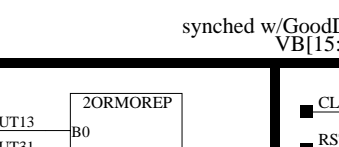
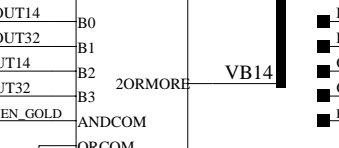
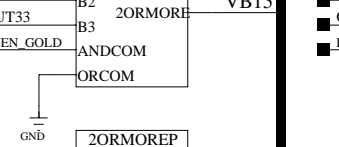
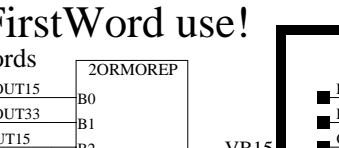
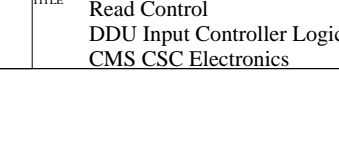
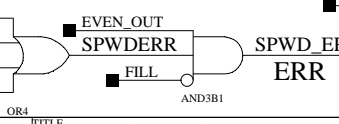
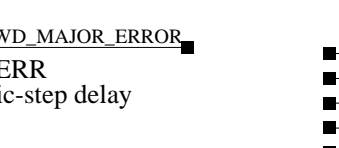
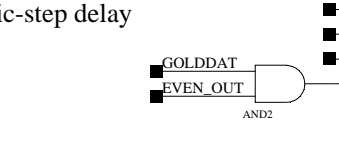

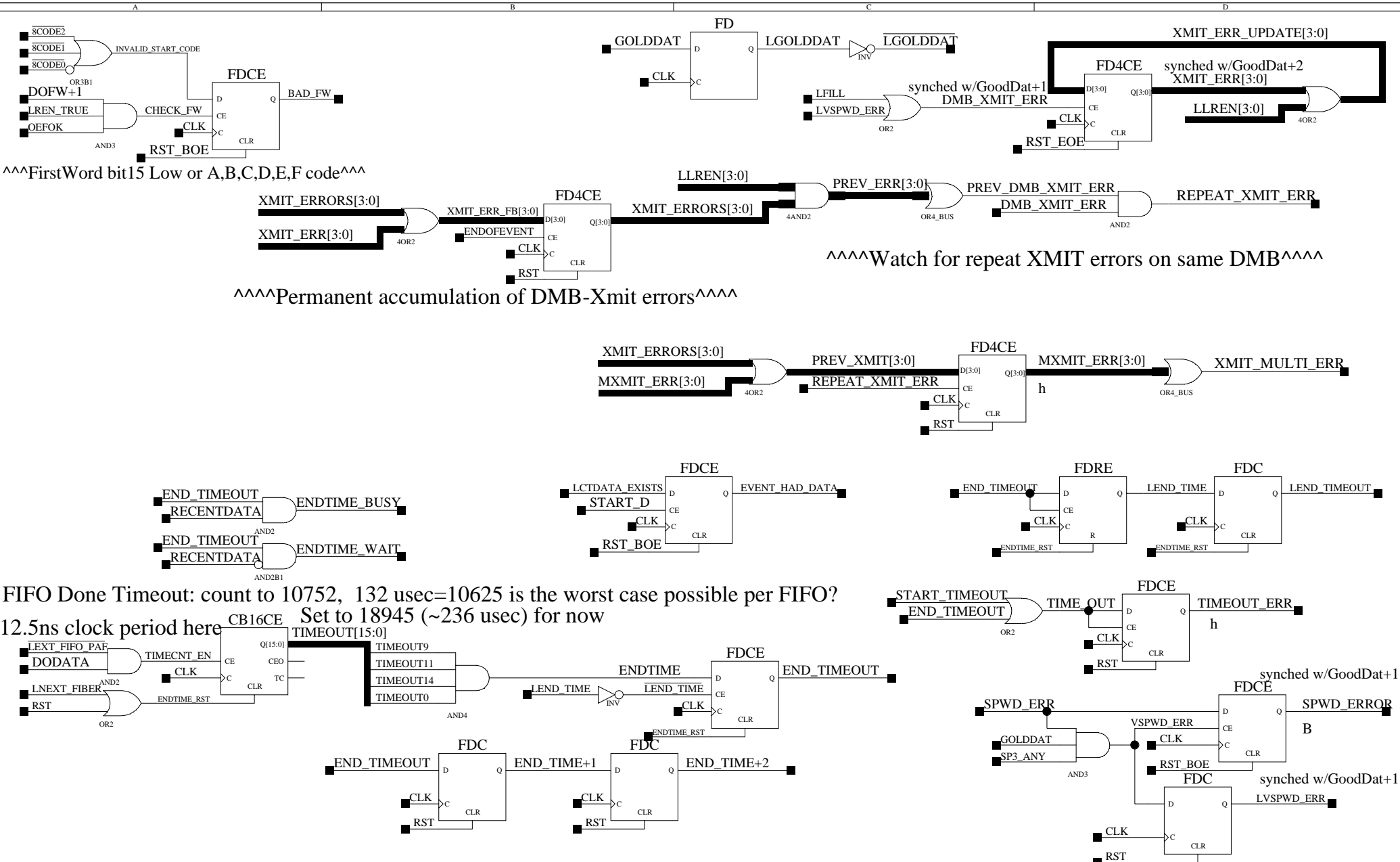

^^^FirstWord bit15 Low or A,B,C,D,E,F code^^^

^^^Permanent accumulation of DMB-Xmit errors^^^

^^^Watch for repeat XMIT errors on same DMB^^^

FIFO Done Timeout: count to 10752, 132 usec=10625 is the worst case possible per FIFO?
 12.5ns clock period here Set to 18945 (~236 usec) for now

Status Monitor

Pick 8 Status signals, include in DAQ HDR/TR

-create logic for OEHDR/TR and their format

Also set 4 FMM bits for each input channel

#Bits usable at EOE (for Used Memories in event? 22 bits)

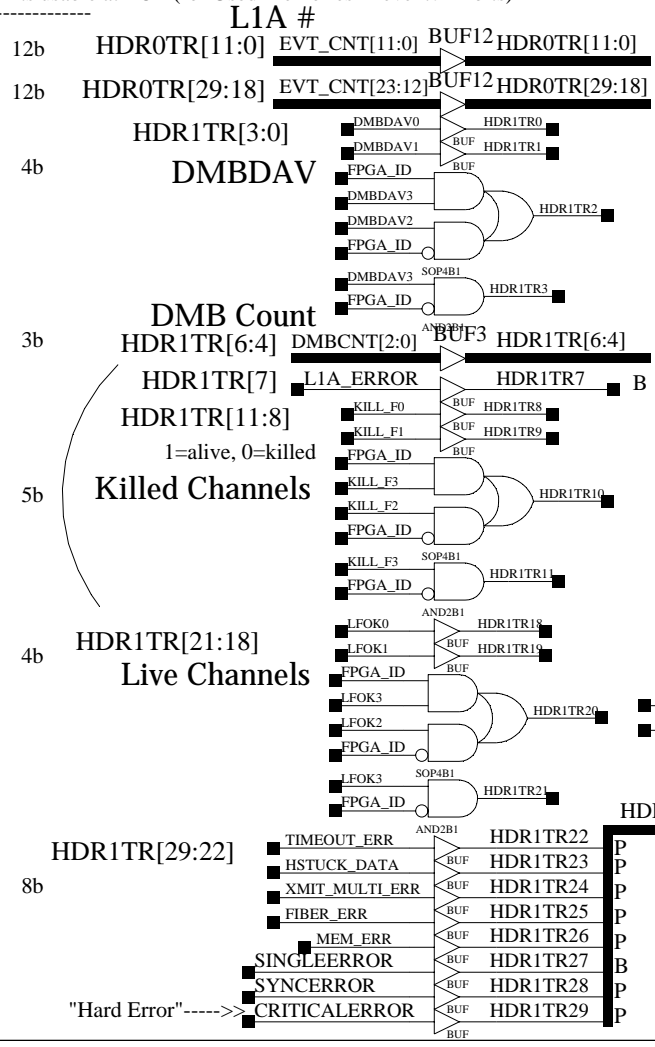

SyncErr AND ~MemErr == MultL1Err

synced to LLLLREN/OE_TR1, inc CritDataErh

Includes DLLerror, RxError, SpwdError

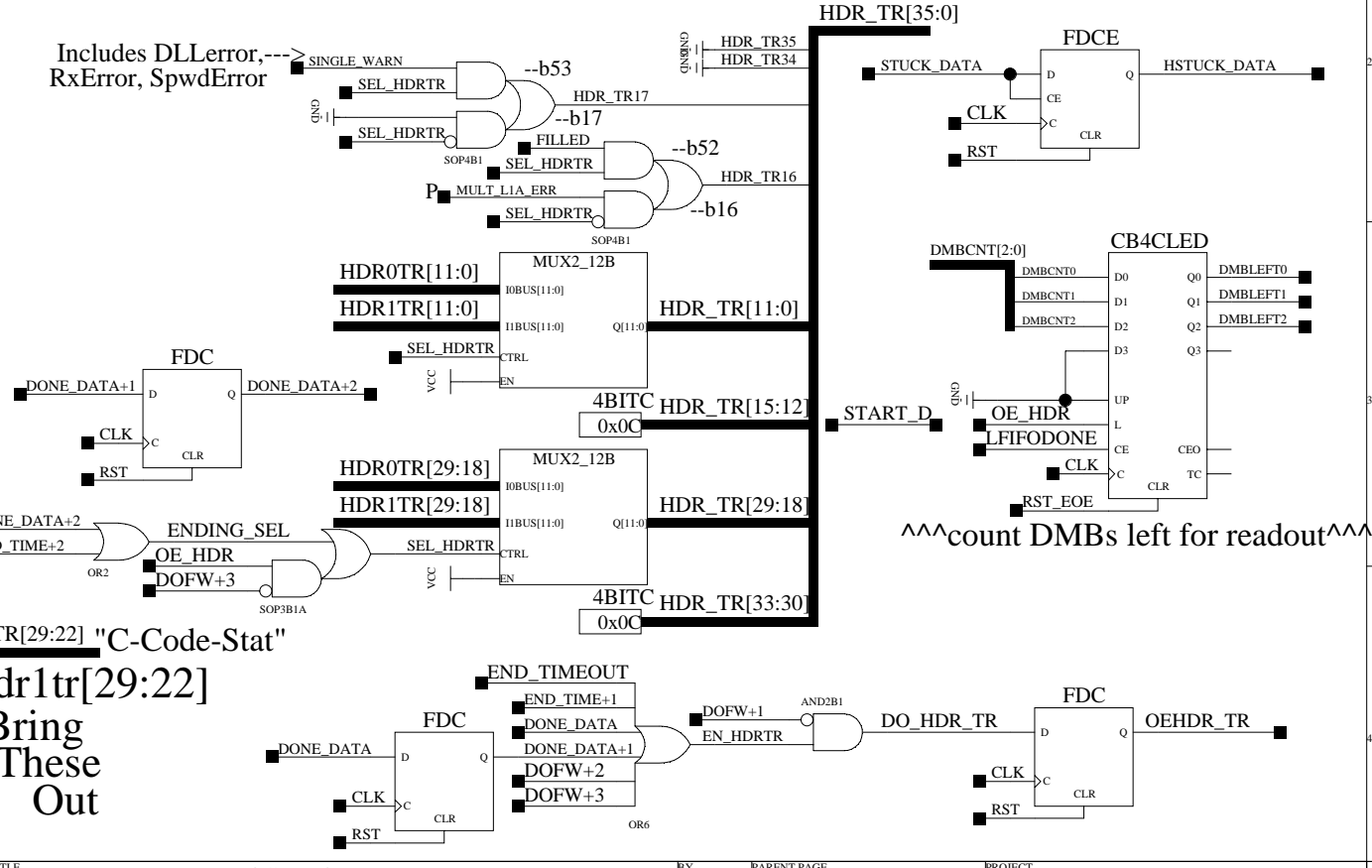

removed from Hdr/Tr---B LSCA_OVFL

--DDUctrl detects easily... "SCA_OVFL"

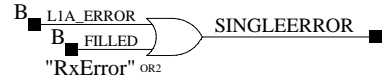

In Hdr/Tr, removed from data---h

--DDUctrl can detect... h

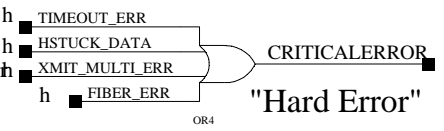
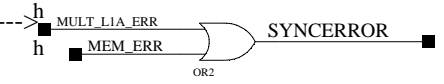

L1A# Mismatch

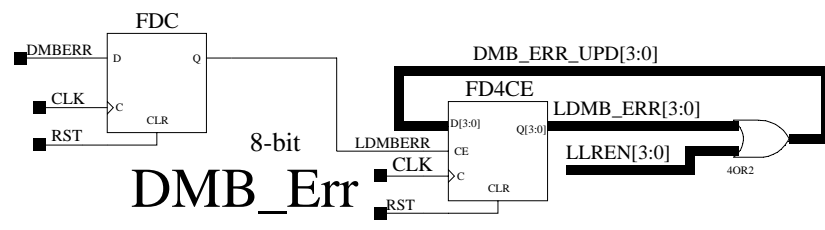
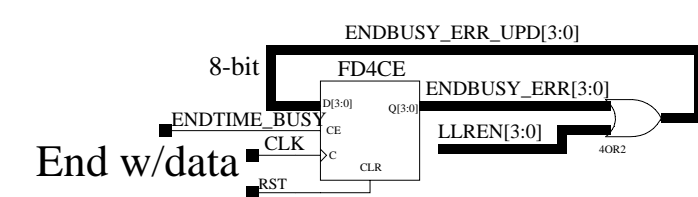
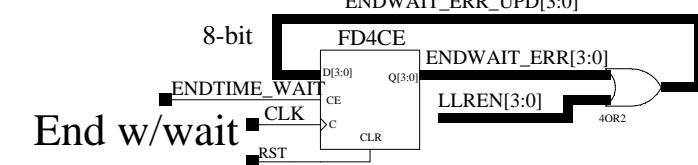
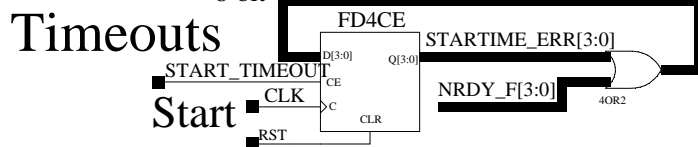
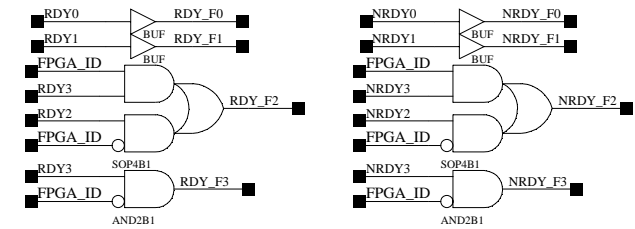
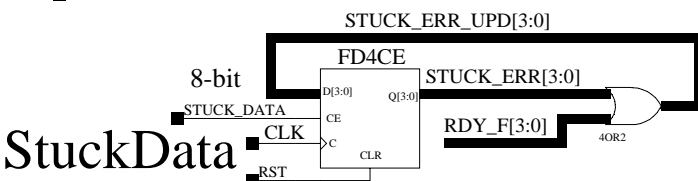
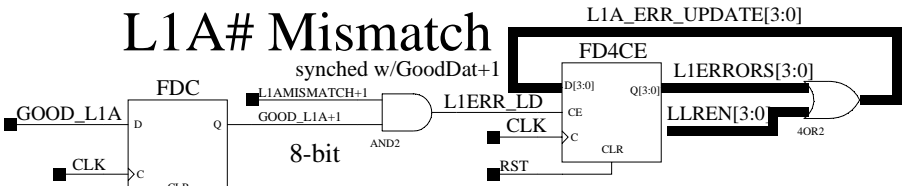

Multi-L1A# Mismatch

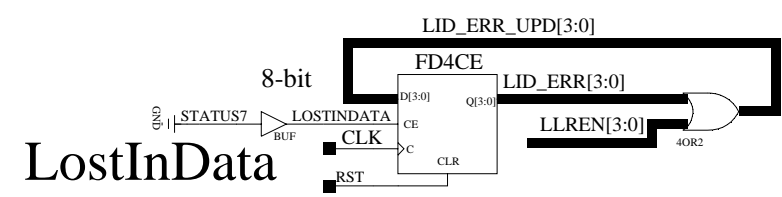
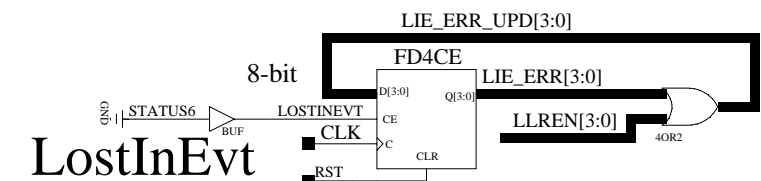
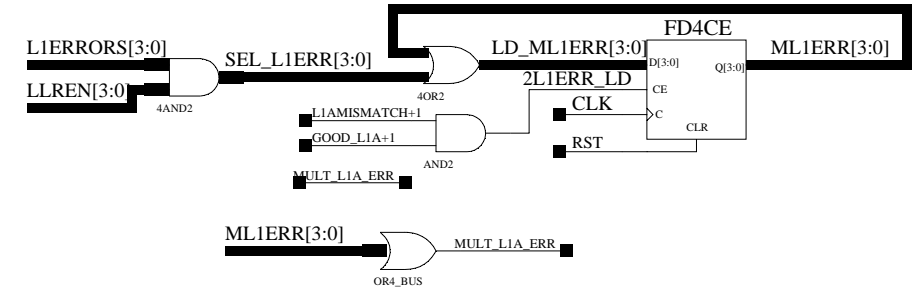

H1: 0x/5T/NN.NNNN/XXX/I.II/VK

H2: 0x/8000/0001/8000/HHHH

H3: 0x/LLLL/oooo/ZZZZ/GGMY

T-2: 0x/8000/FFFF/8000/8000

T-1: 0x/SSSS.SSSS/QQQQ/PPPP

TR: 0x/A/?/WW.WWWW/RRRR/UUMK

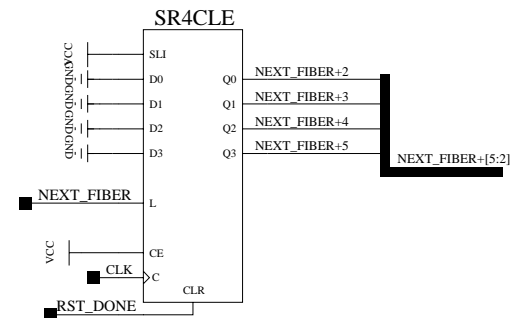



SPS BXN cycle from 0 to 923: CLR after 923=0x39B.

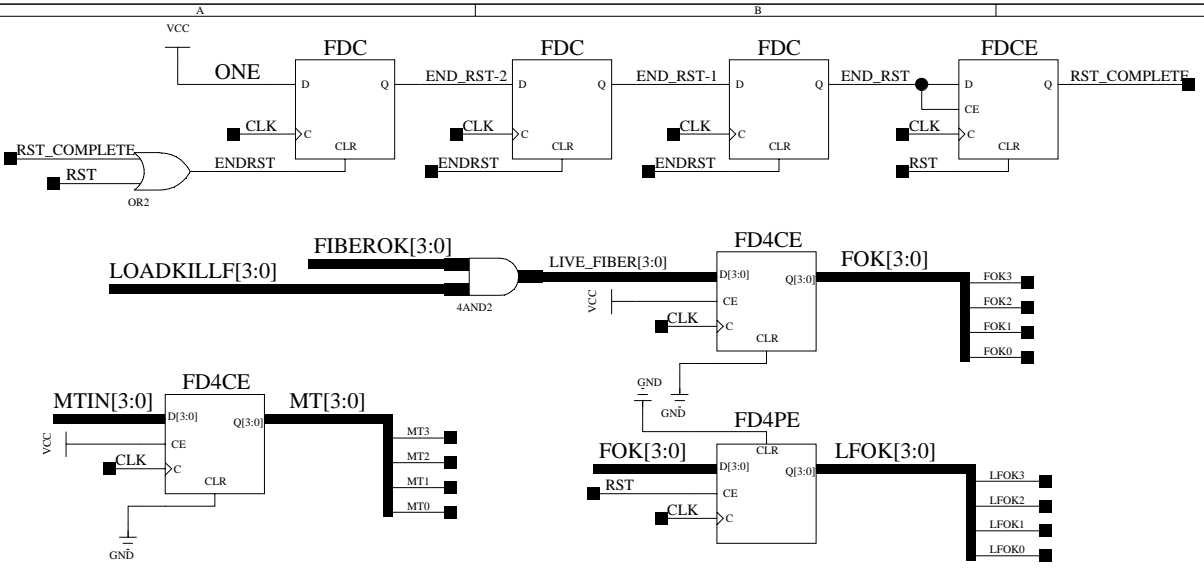

Access FIBEROK from JTAG as a fiber check.
 ---> RESET required after fiber status change for now...
 Change in FIBEROK is BAD! Set error code.
 ...notify FMM and maybe set STATUS bit, but
 ...data is OK until FIFO read time-out occurs.
 ...but how to know WHEN the bad-data comes out?
 ---> timeout will probably occur for that event

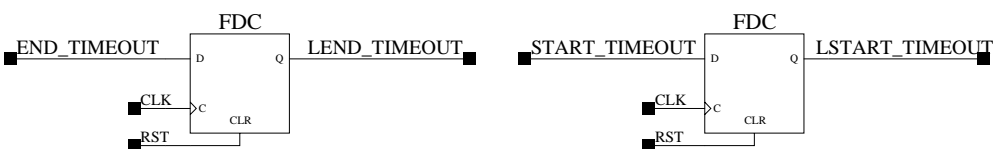

MASK fiber on Start/End TIMEOUT? Kill it in LFOK...

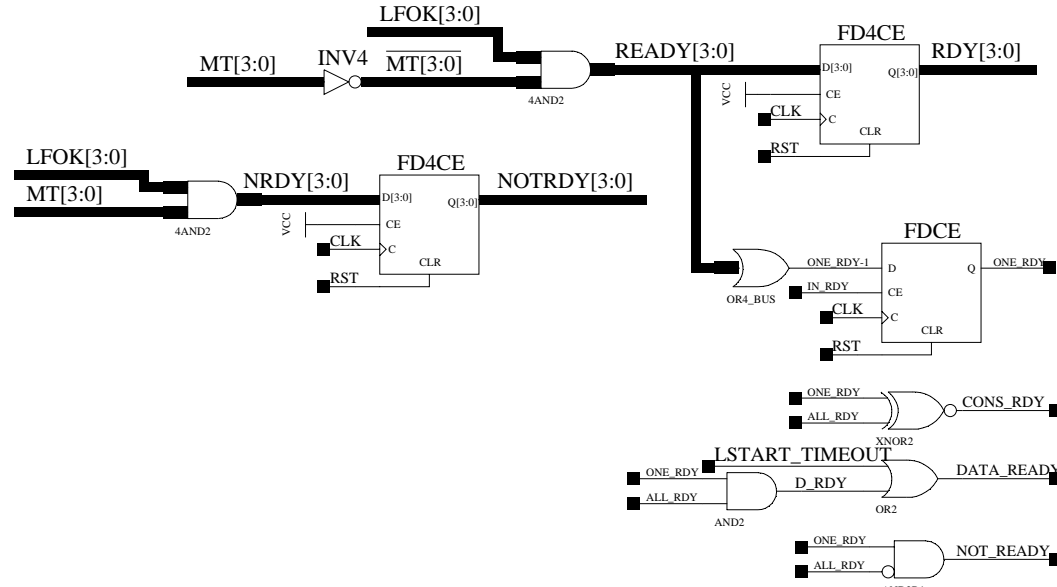

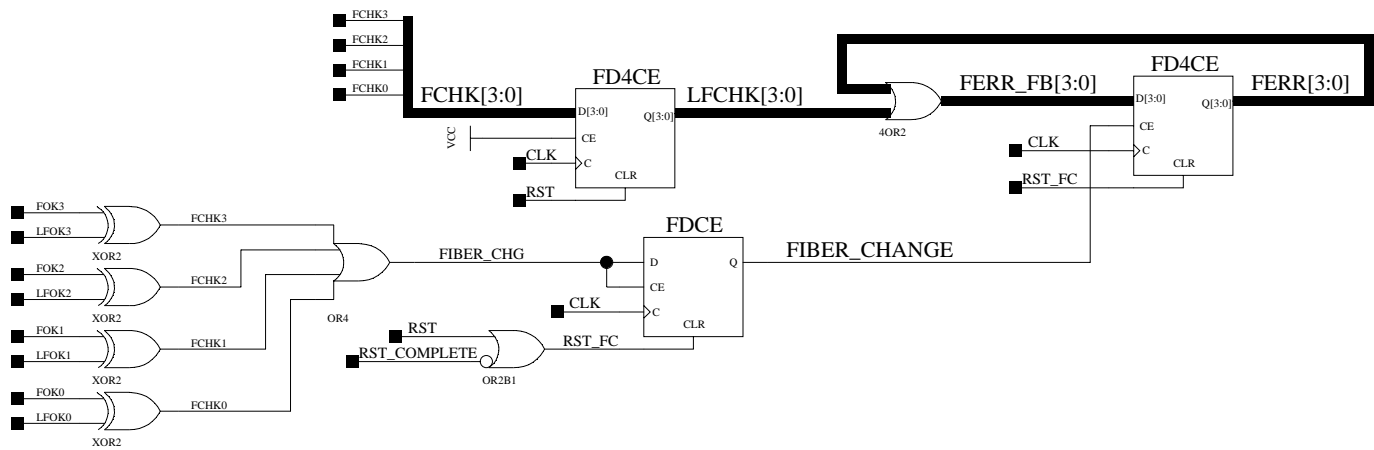

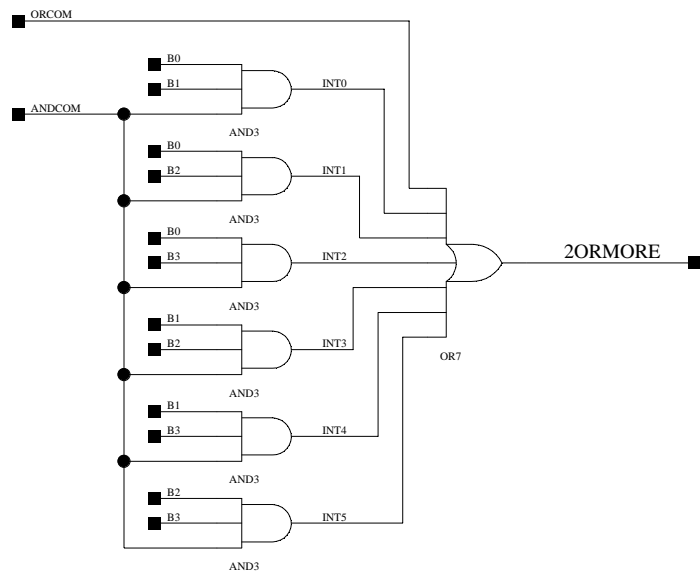

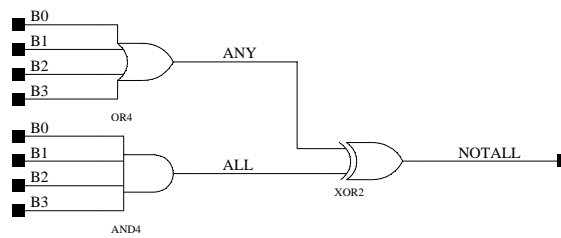

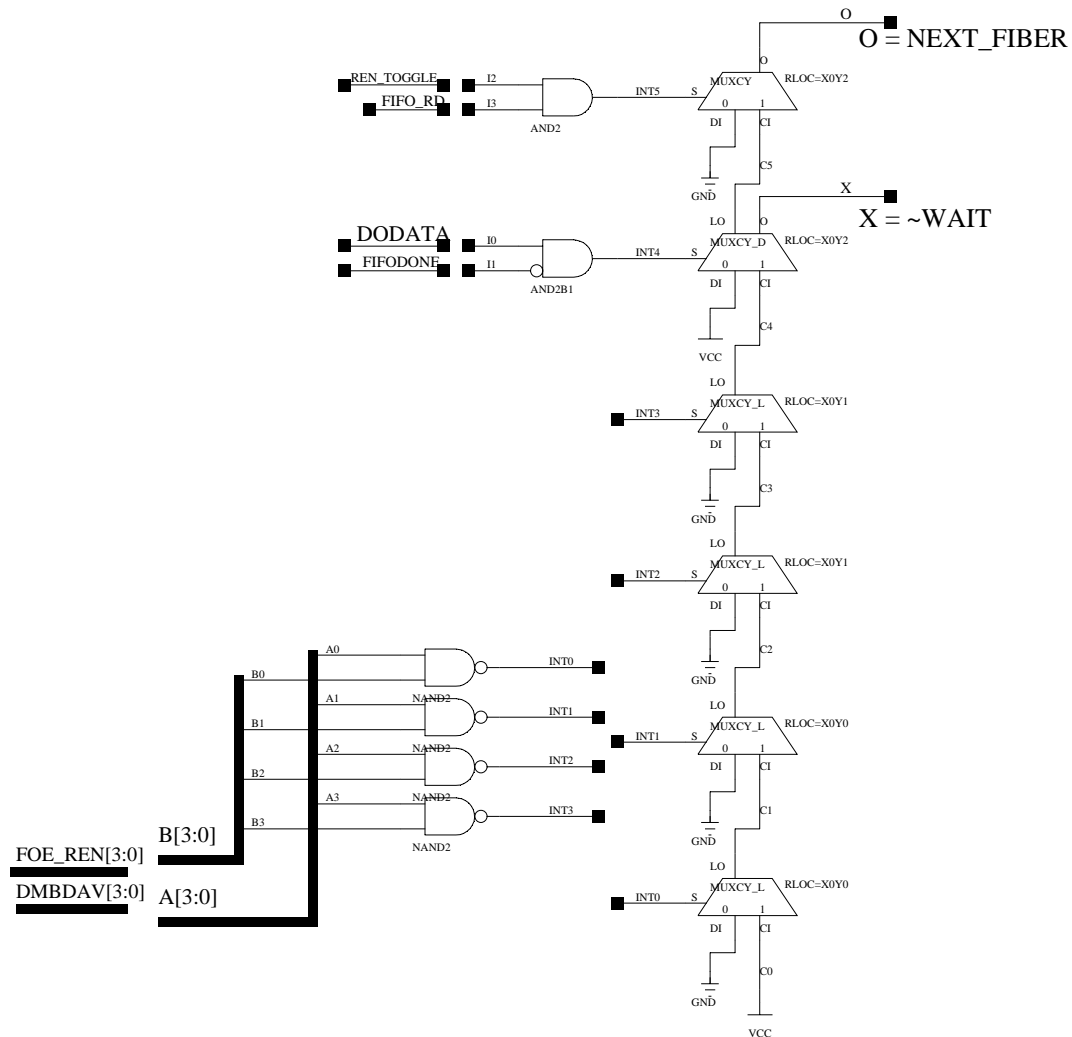

		JRG
Title:	FAST12B1	
Comments:	Custom Fast, Complex Logic for DDU, use 4 MUXCY as OR, 2 as AND similar to: OR of 4 AND2 .AND. AND2B1 .AND. AND2	
Date:	15th October 2003	Ver: 1
Sheet Size:	B	Rev: A

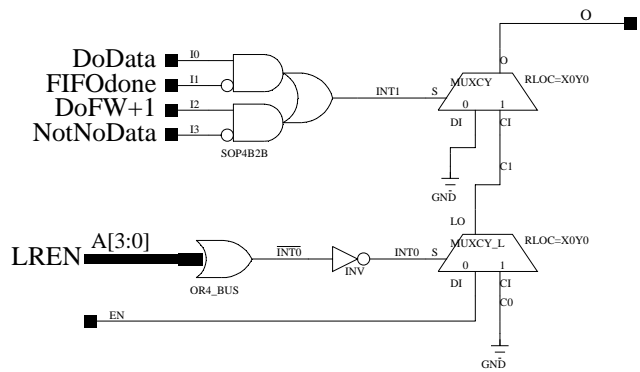

JRG

Title:	FAST8B2EN	
Comments:	Custom Fast, Complex Logic for DDU, use 2 MUXCY as AND similar to: OR4 AND SOP4B2b	
Date:	14th September 2004	Ver: 1
Sheet Size: B		Rev: A

the D byte goes out last (on C rising edge)
 the F byte goes out first (on C falling edge)

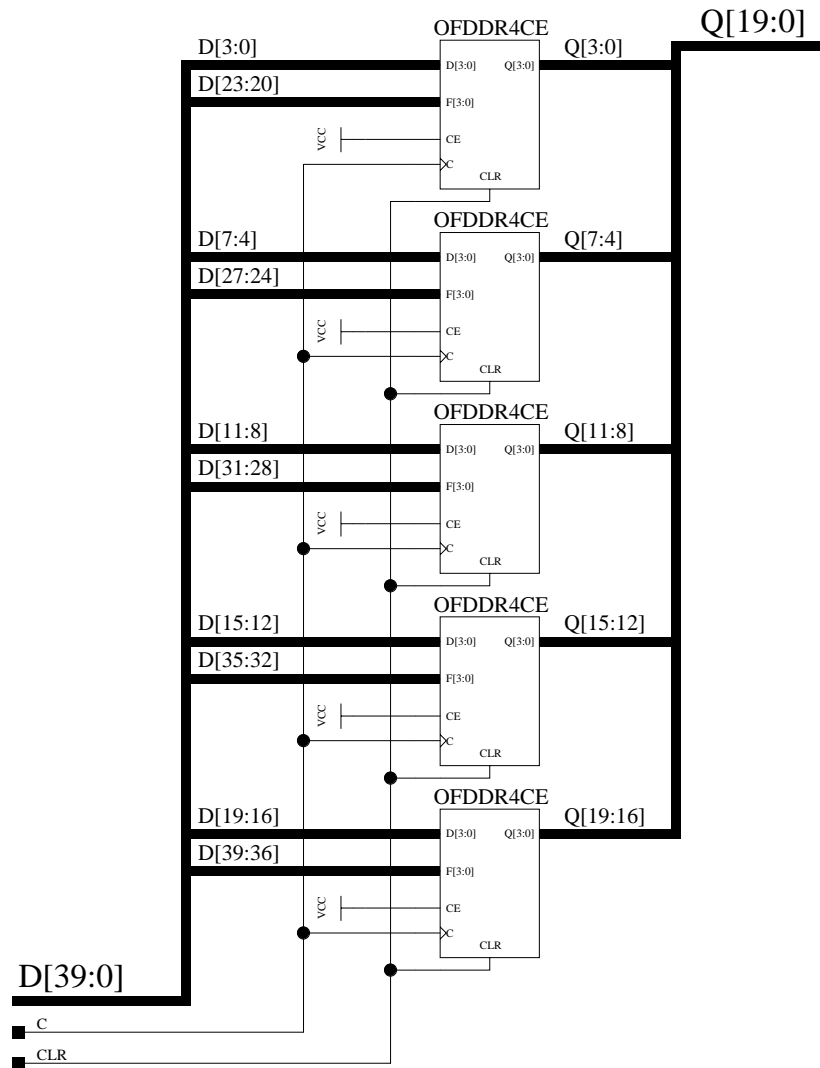

Title: VIRTEX Family OFDDR40 Macro		
Comments: 40-Bit Output DDR Flip-Flop w/Asynchronous Clear		JRG
Date:	16th December 2003	Ver: 1
Sheet Size: B		Rev: A

the D byte goes out last (on C rising edge)
 the F byte goes out first (on C falling edge)

Q[3:0]

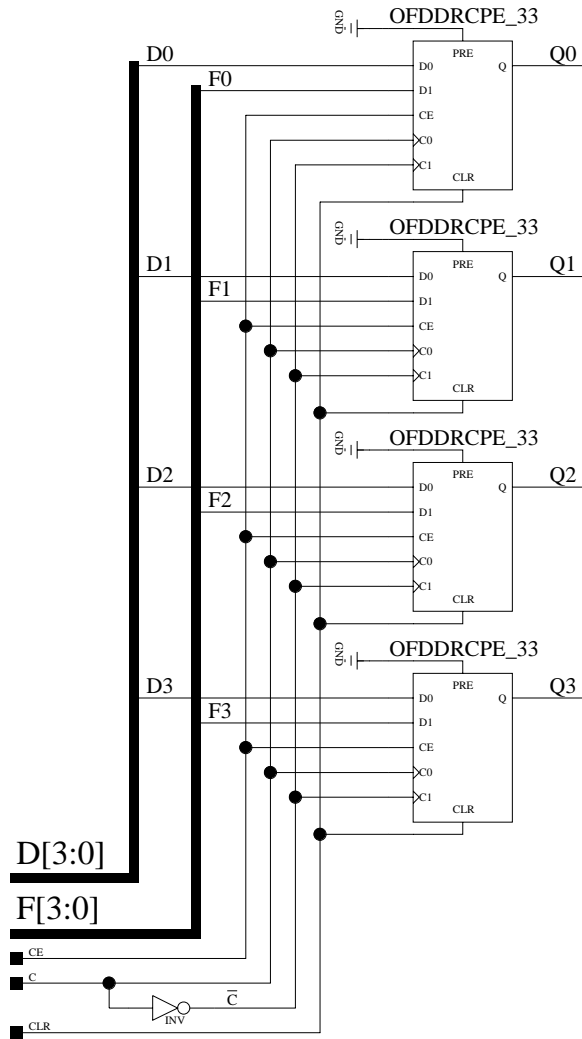

Title: VIRTEX Family OFDDR4 Macro	
JRG	
Comments: 4-Bit Output DDR Flip-Flop w/Asynchronous Clear and Clock Enable	
Date: 16th December 2003	Ver: 1
Sheet Size: B	Rev: A

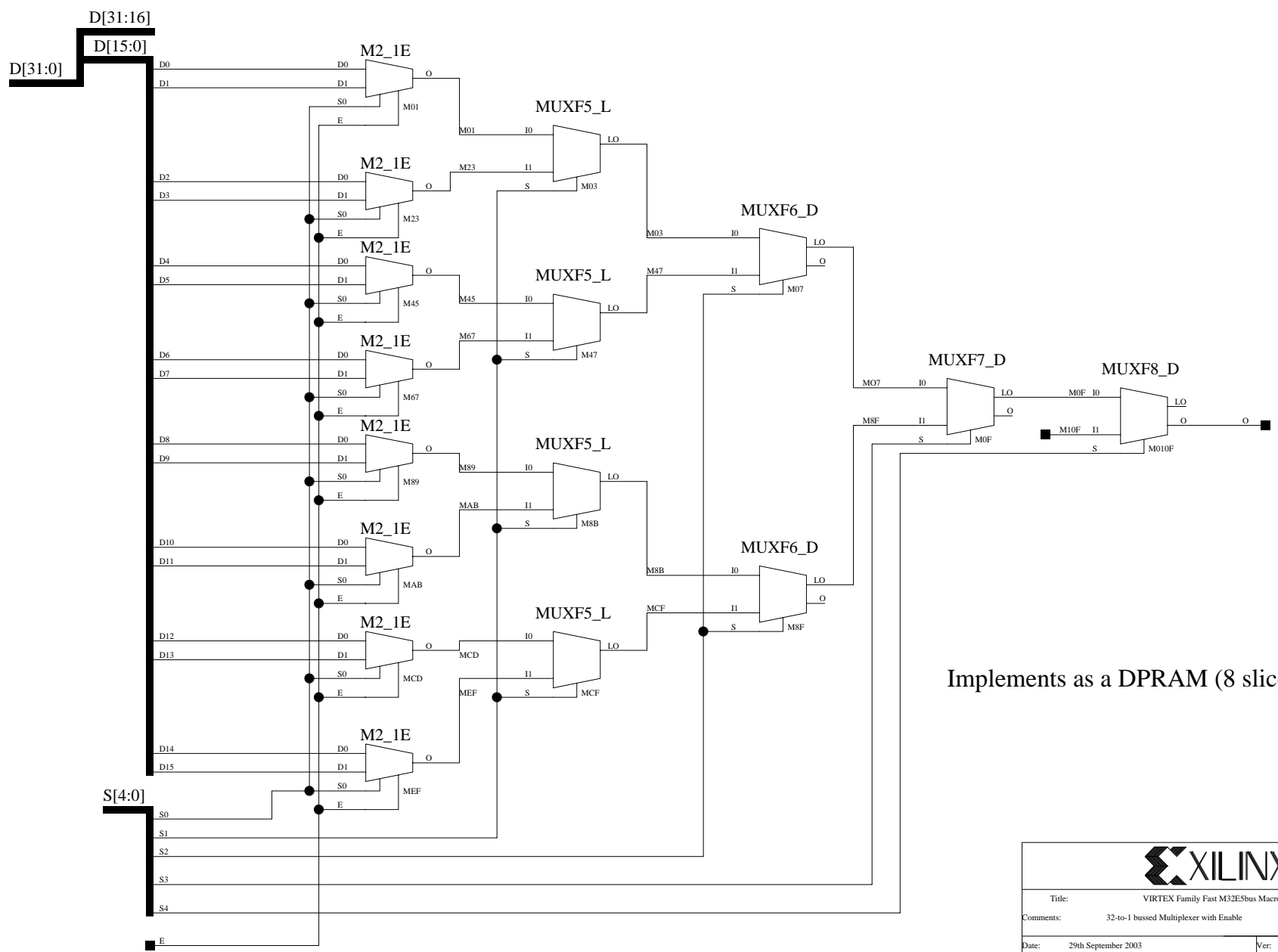

Implements as a DPRAM (8 slices)

		JRG
Title:		VIRTEX Family Fast M32ESbus Macro
Comments:		32-to-1 bussed Multiplexer with Enable
Date:	29th September 2003	Ver: 1
Sheet Size:	B	Rev: A

D[31:16]

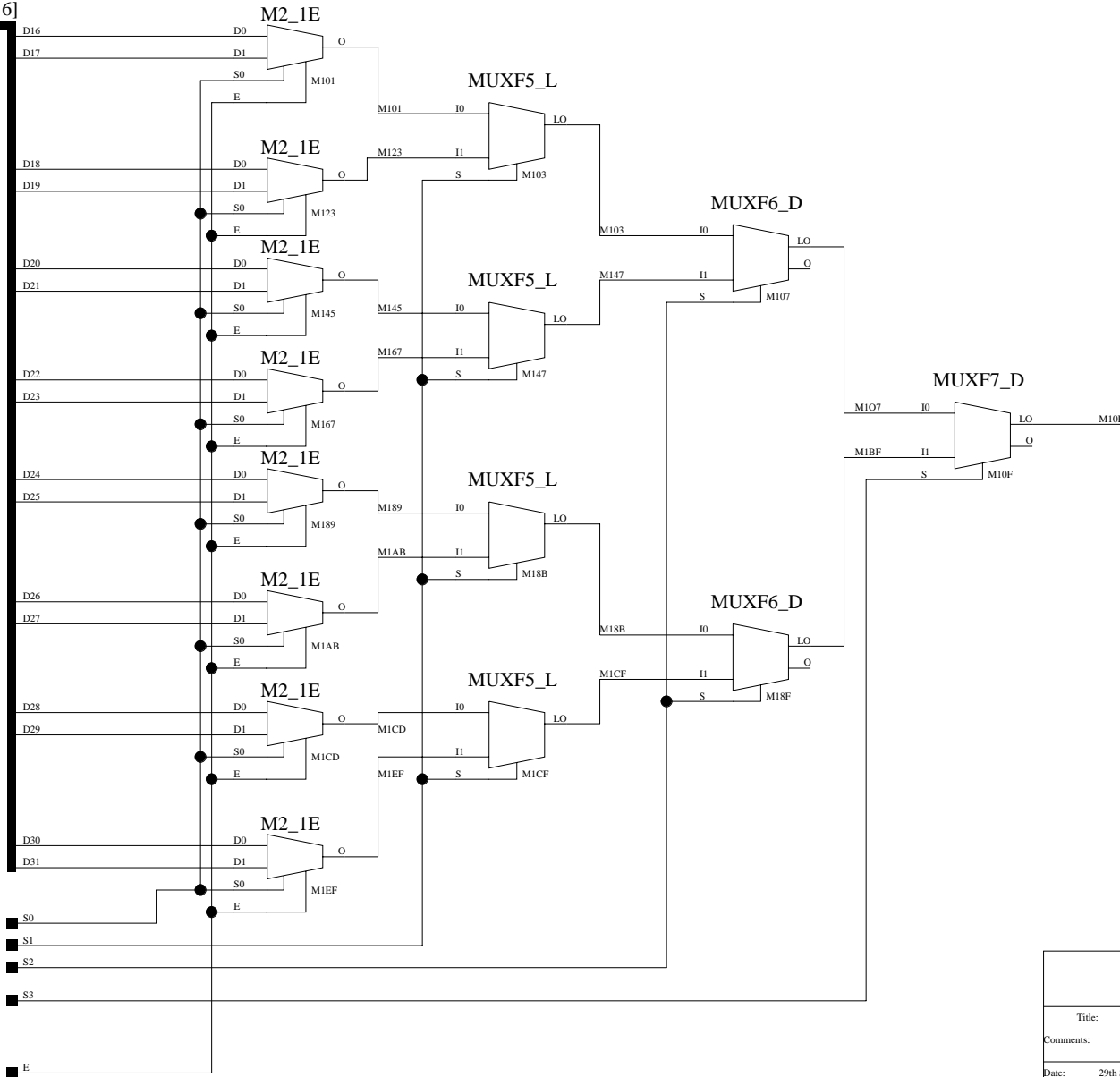

drawn by KS
Copyright (c) 1993, Xilinx Inc.

		JRG
Title:		VIRTEX Family Fast M32ESbus Macro
Comments:		32-to-1 bussed Multiplexer with Enable
Date:	29th September 2003	Ver: 1
Sheet Size:	B	Rev: A

JTAG Instruction Decode

OpCode	Function [OpName]
0	No Operation [NOOP]
1	FPGA Reset [toggle]
2	RdCtrl0 Current DDU L1A Number (24-bit scaler)
3	Check status (capture and shift) [32 bits]
4	Check status, low-word [16 bits]
5	Check status, high-word [16 bits]
7	6a Check FiberOK status (Check_FOK) [8 bits]
6	6b Check FiberErr status (Check_Ferr) [8 bits]
11	7a L1A Mismatch [8-bits]
26	7b Stuck Buffer Errors [8-bits]
25	8a FIFO Empty Status [10-bits]
20	8b Almost Full FIFOs [6-bits]
21	9 Full FIFOs [12-bits]
13	10a Timeout: start [8-bits]
17	10b RX Errors [8-bits]
14	11a Timeout: end-wait [8-bits]
15	11b Timeout: end-active [8-bits]
12	12a Data Xmit Errors [8-bits]
16	12b DMB Errors [8-bits]
13	Fiber 1 & 0 Write Memory [10-bits]
14	Fiber 3 & 2 Write Memory [10-bits]
15	Fiber 5 & 4 Write Memory [10-bits]
16	Fiber 7 & 6 Write Memory [10-bits]
17	FIFO Mem Available 1 & 0 [10-bits]
18	FIFO Mem Min Available 1 & 0 [10-bits]
19	*19a Lost In Data [8-bits]
18	*19b Lost In Event [8-bits]
20	C-Code Status [16-bits]
21	DMB Warn/Full Status [16-bits]
22	Status Register A [16-bits]
23	Status Register B [16-bits]
24	Status Register C [16-bits]
25	Diagnostic Trap [192-bits]
26	RdCtrl1 Current DDU L1A Number (24-bit scaler)
*28	# Mem assigned to Fibers 2-0 [16-bits]
*30	Fiber 3-0 Mem Diagnostic [InRD0, 4 * 8-bits]
*31	Fiber 7-4 Mem Diagnostic [InRD1, 4 * 8-bits]

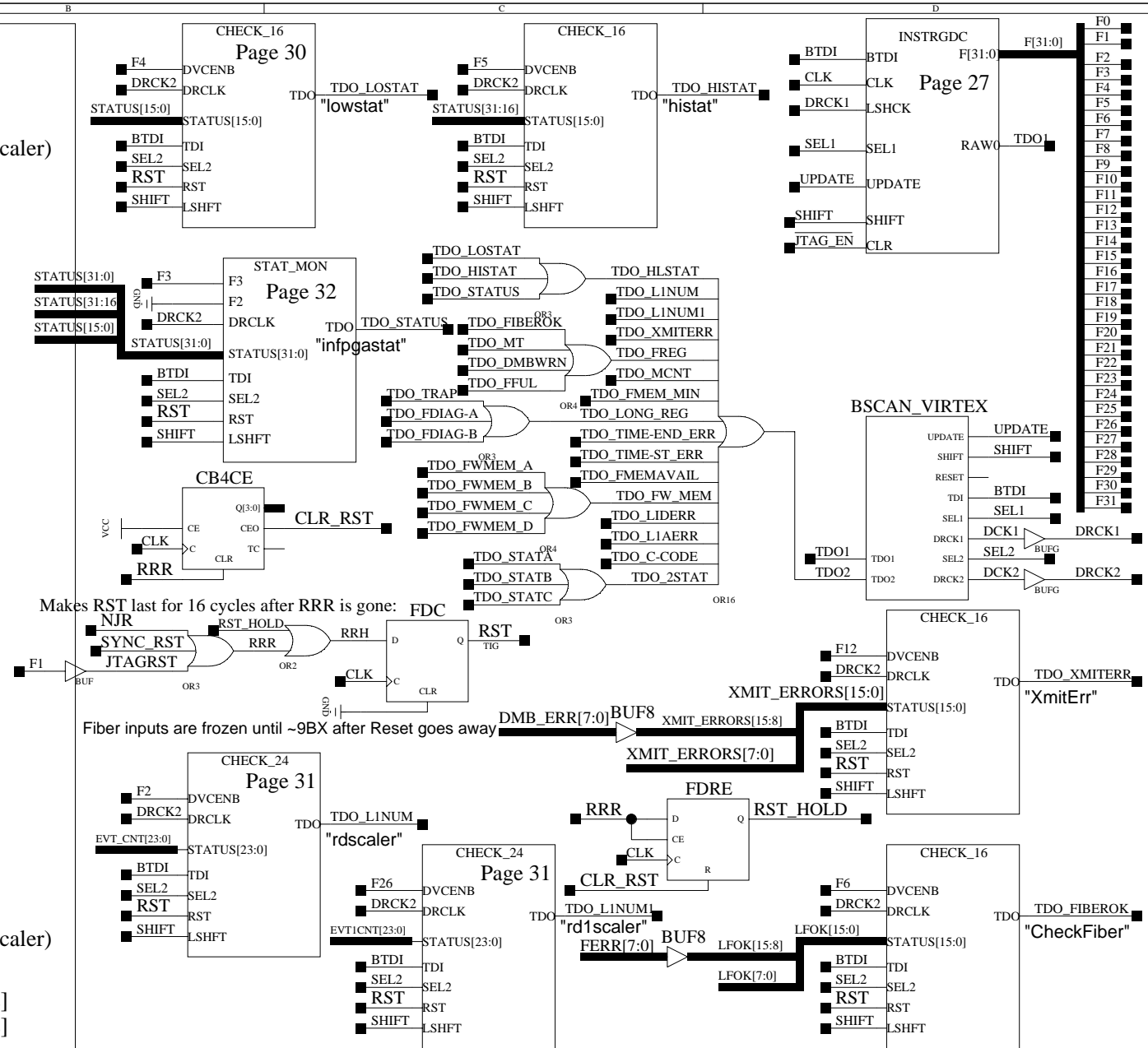

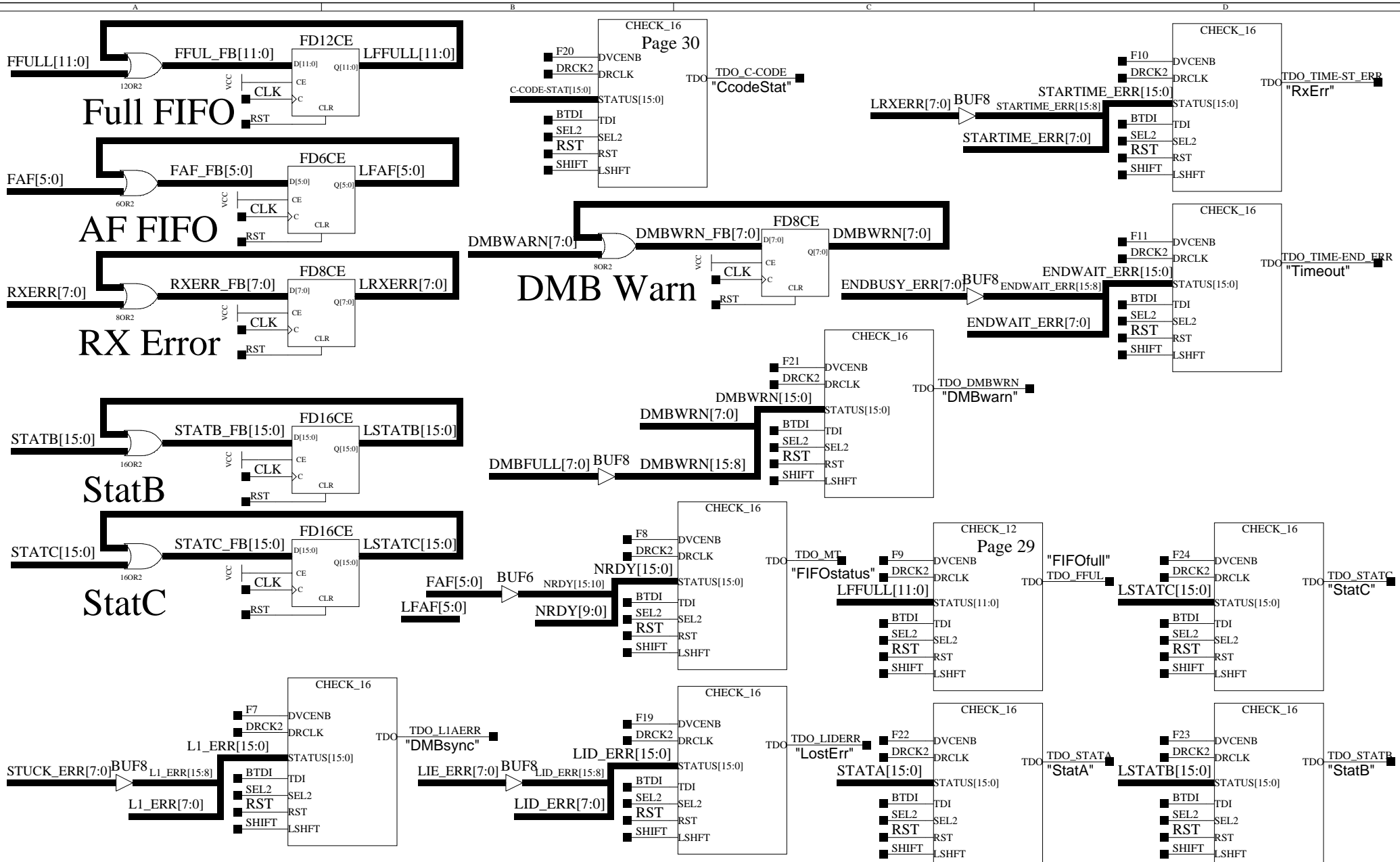

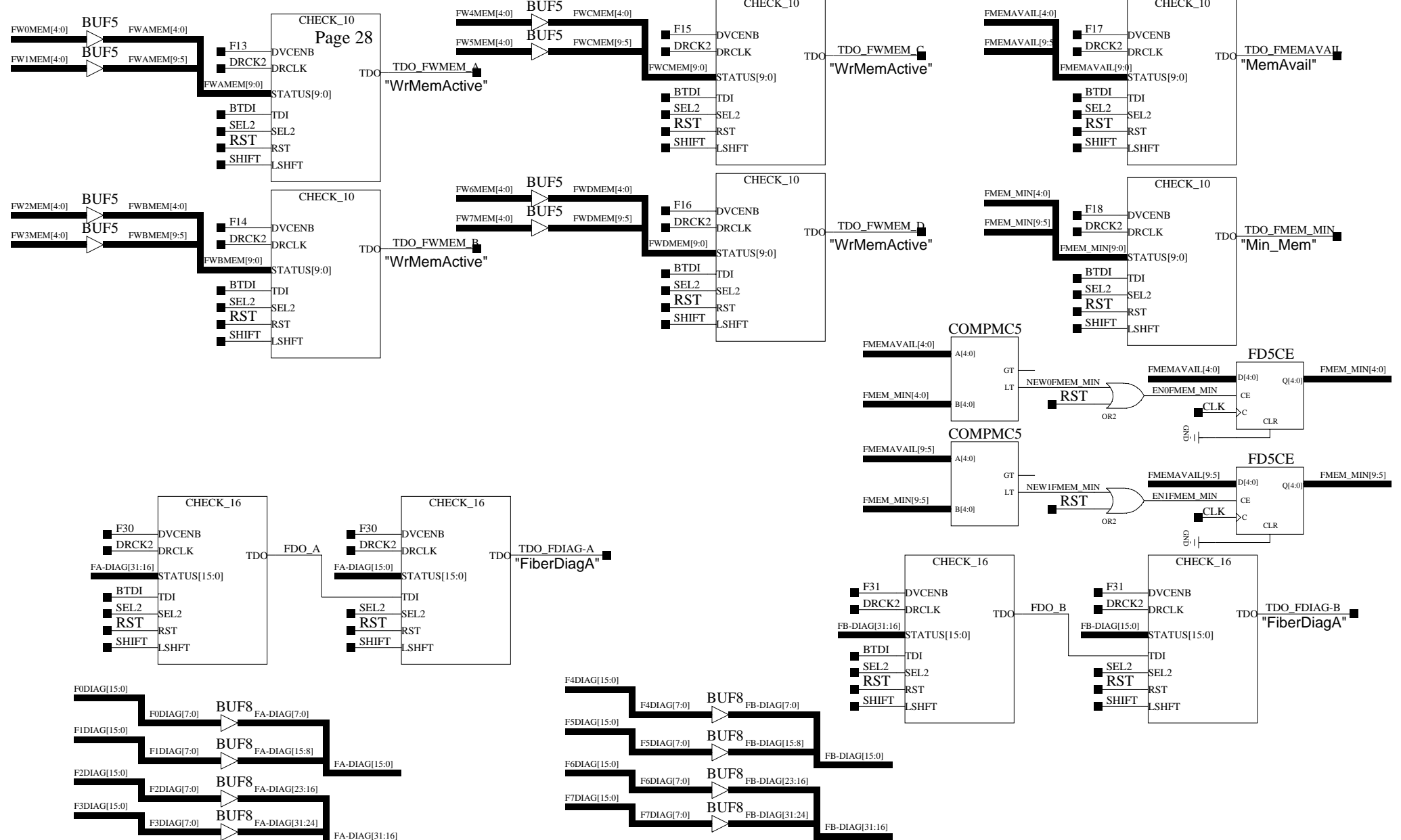

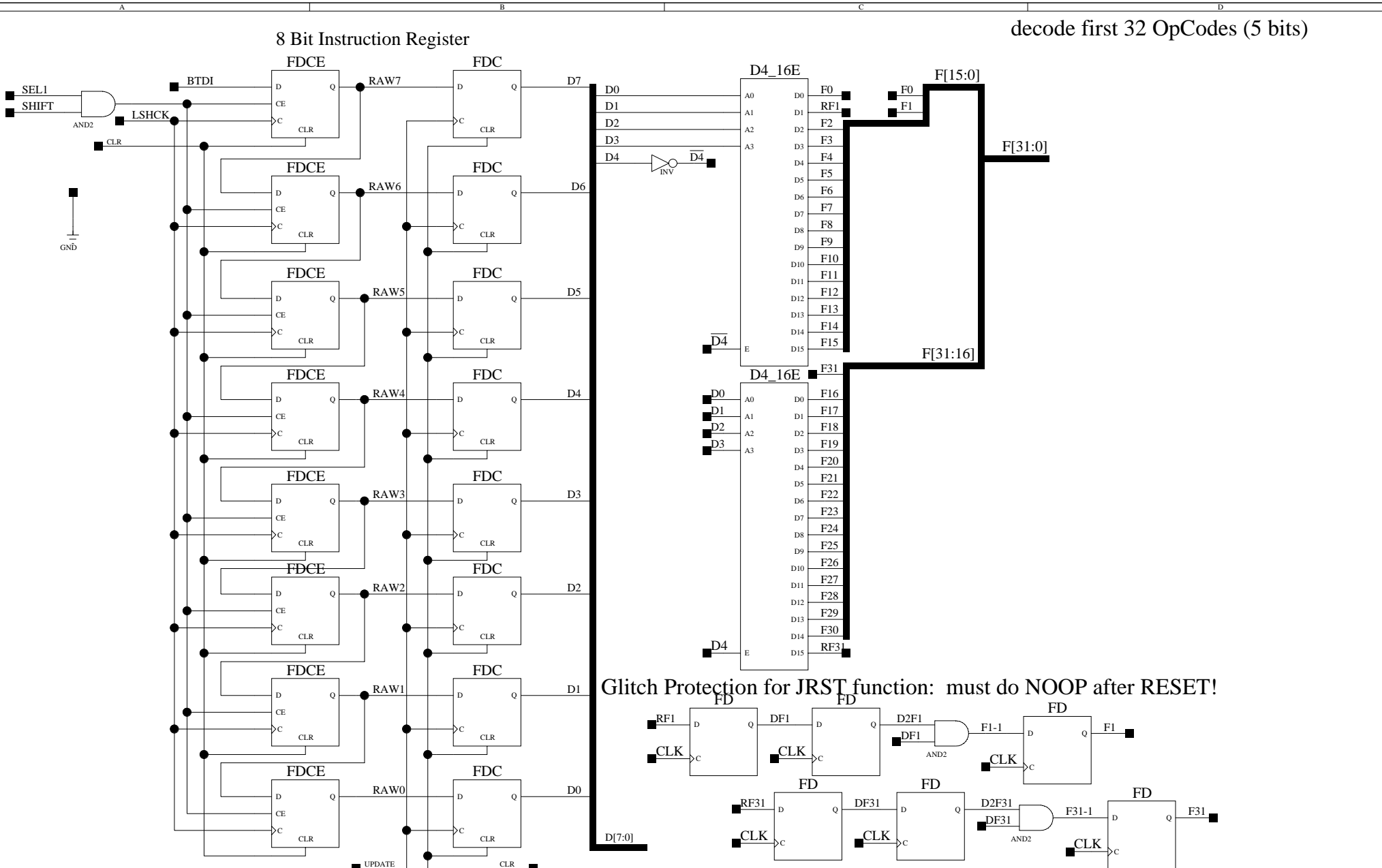

10-bit JTAG Register Read out (on DVCENB)

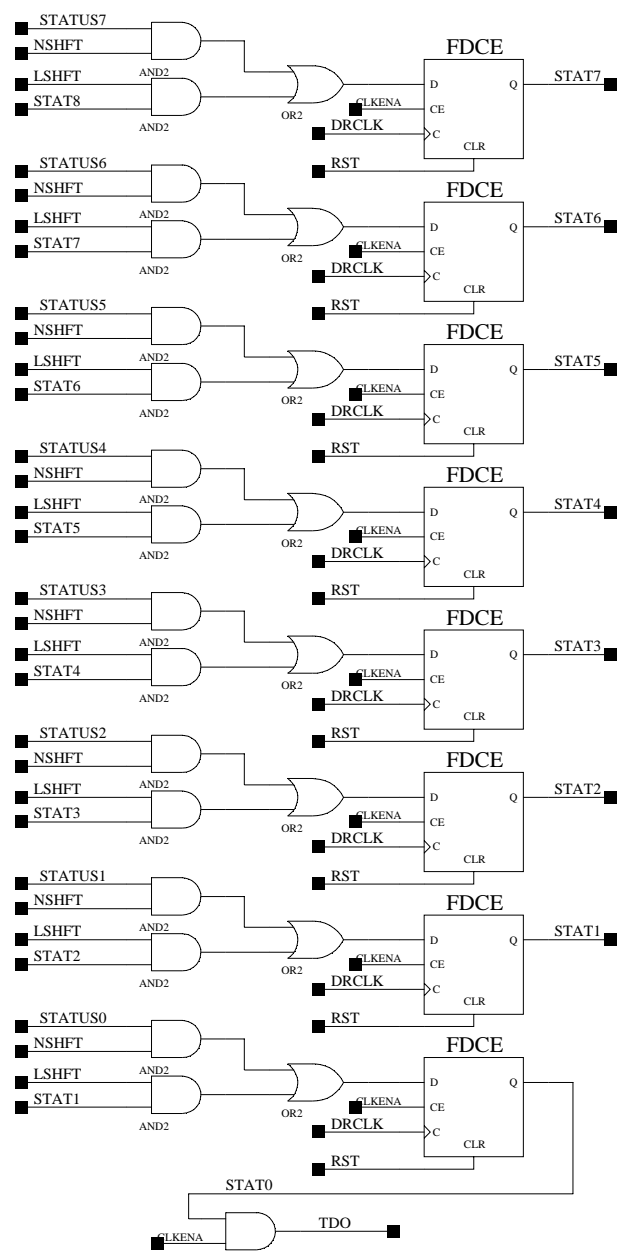
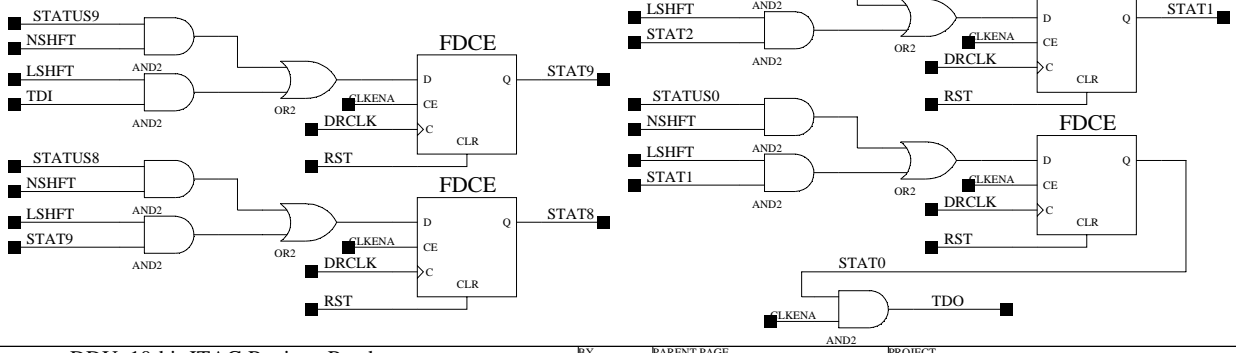
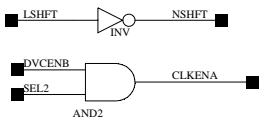
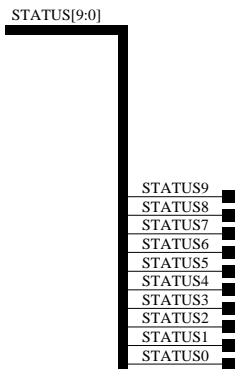

12-bit JTAG Register Read out (on DVCENB)

STATUS[11:0]

- STATUS11
- STATUS10
- STATUS9
- STATUS8
- STATUS7
- STATUS6
- STATUS5
- STATUS4
- STATUS3
- STATUS2
- STATUS1
- STATUS0

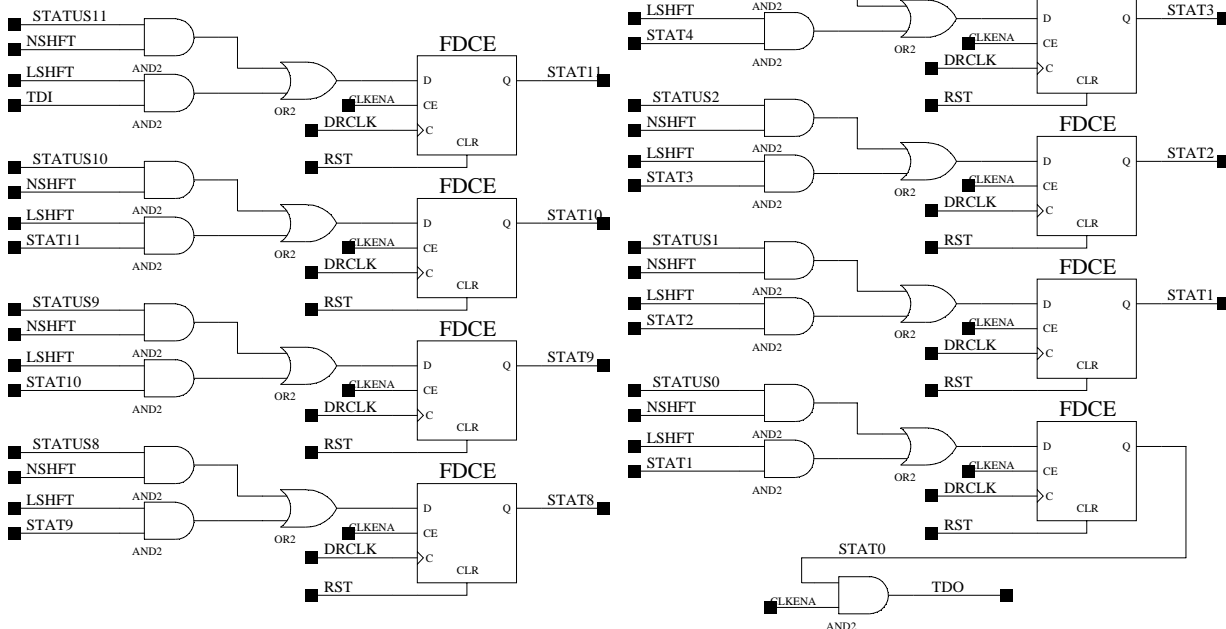
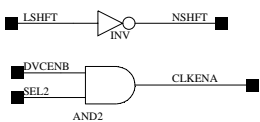

16-bit JTAG Register Read out (on DVCENB)

STATUS[15:0]

- STATUS15
- STATUS14
- STATUS13
- STATUS12
- STATUS11
- STATUS10
- STATUS9
- STATUS8
- STATUS7
- STATUS6
- STATUS5
- STATUS4
- STATUS3
- STATUS2
- STATUS1
- STATUS0

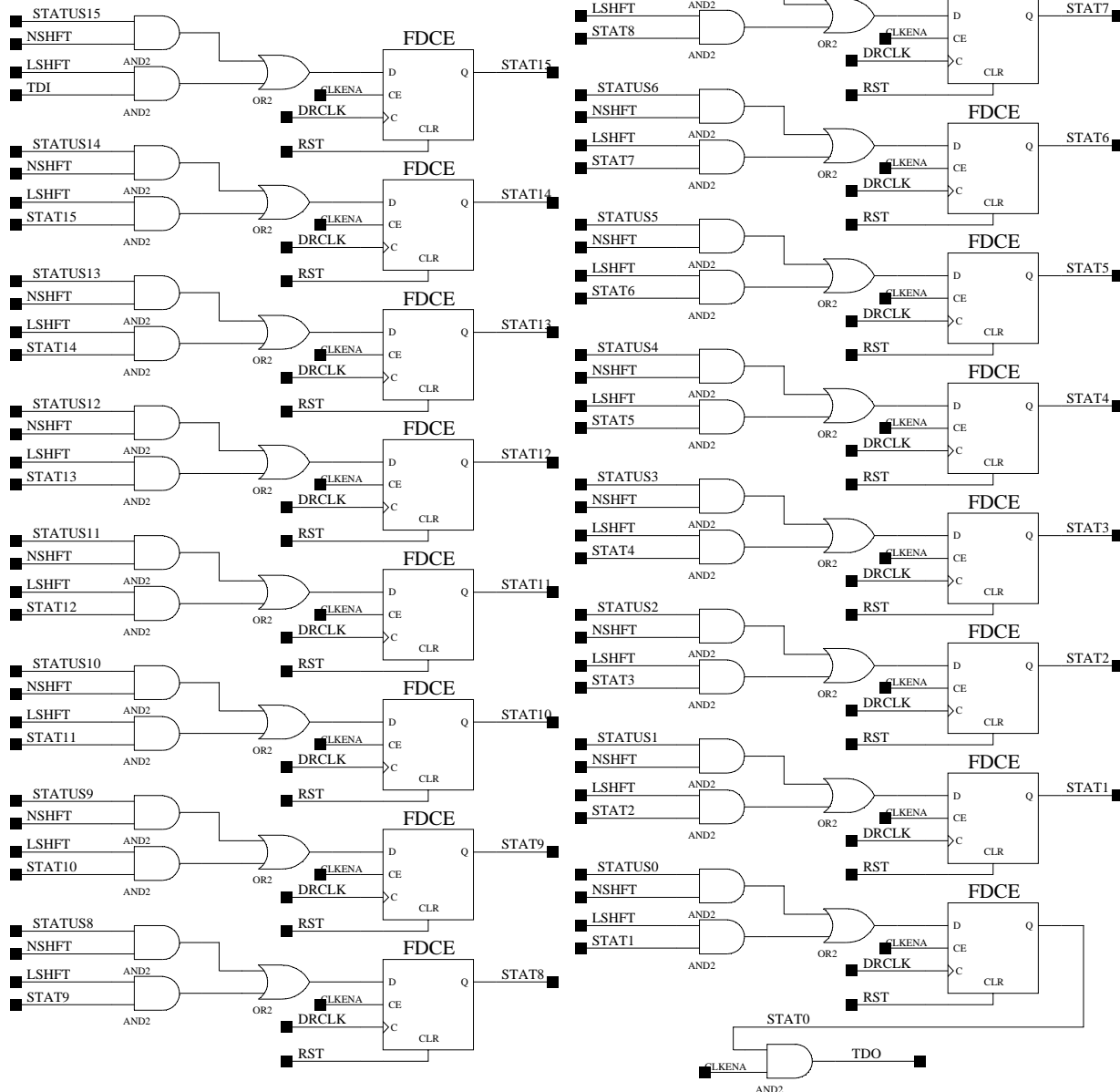
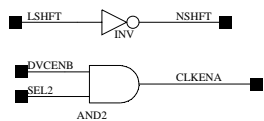

24-bit JTAG Register Read out (on DVCENB)

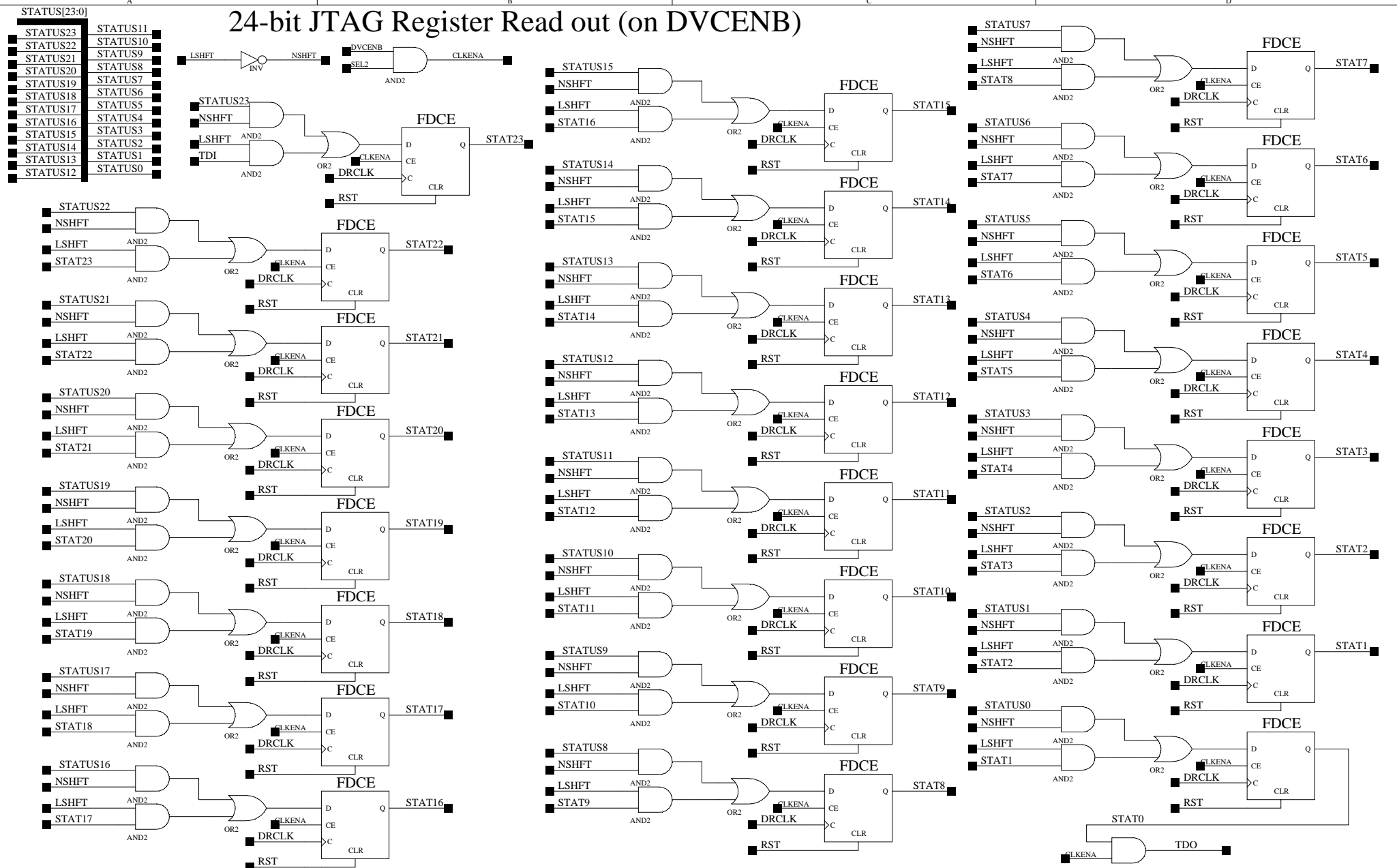

STATUS[23:0]	STATUS11
STATUS23	STATUS10
STATUS22	STATUS9
STATUS21	STATUS8
STATUS20	STATUS7
STATUS19	STATUS6
STATUS18	STATUS5
STATUS17	STATUS4
STATUS16	STATUS3
STATUS15	STATUS2
STATUS14	STATUS1
STATUS13	STATUS0
STATUS12	

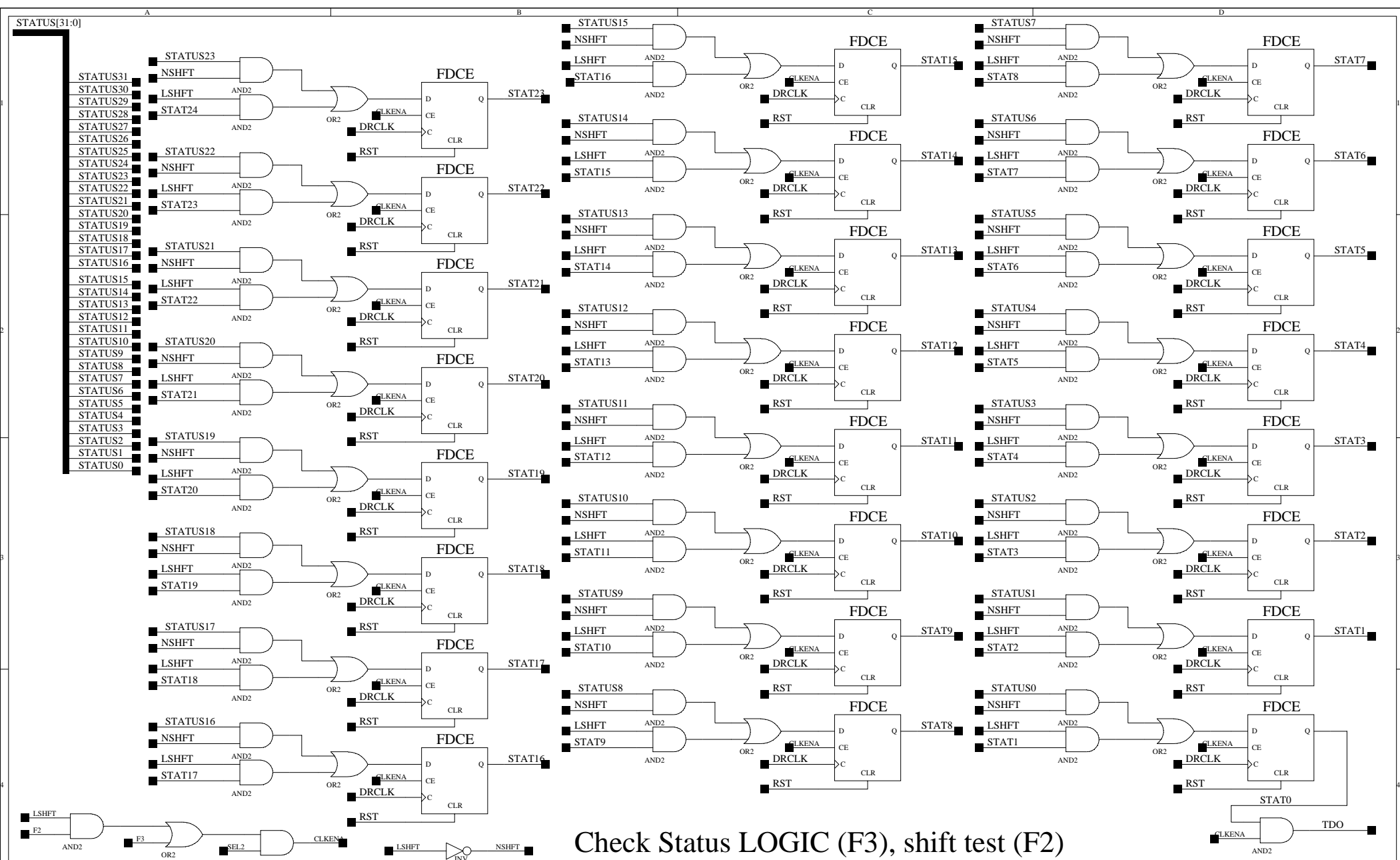

Check Status LOGIC (F3), shift test (F2)

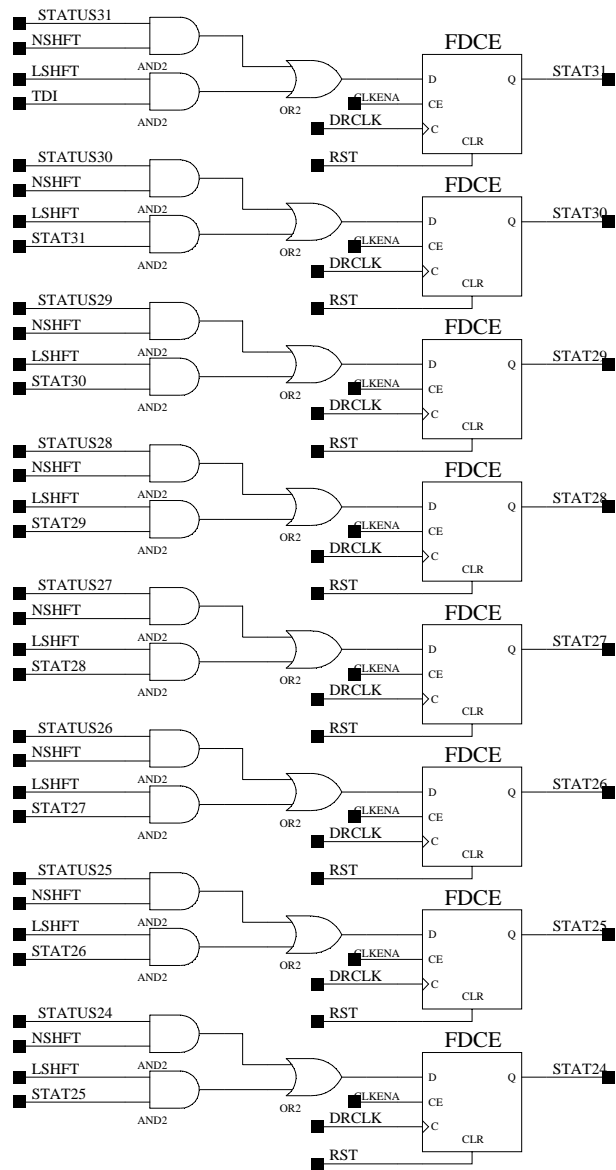

FOK LED

- LIT == Link is alive and well
- BLINK == Link not ready
- OFF == Link not present

DAV LED

- LIT == Active Data Xmit
- OFF == No data to Xmit

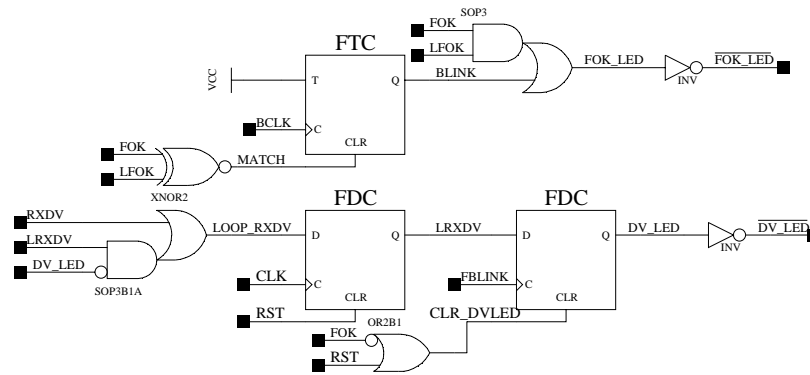

JRG

Title:	FIBERLED	
Comments:	Custom LED Slow-Blink Control for Fiber Inputs	
Date:	27th January 2004	Ver: 1
Sheet Size:	B	Rev: A

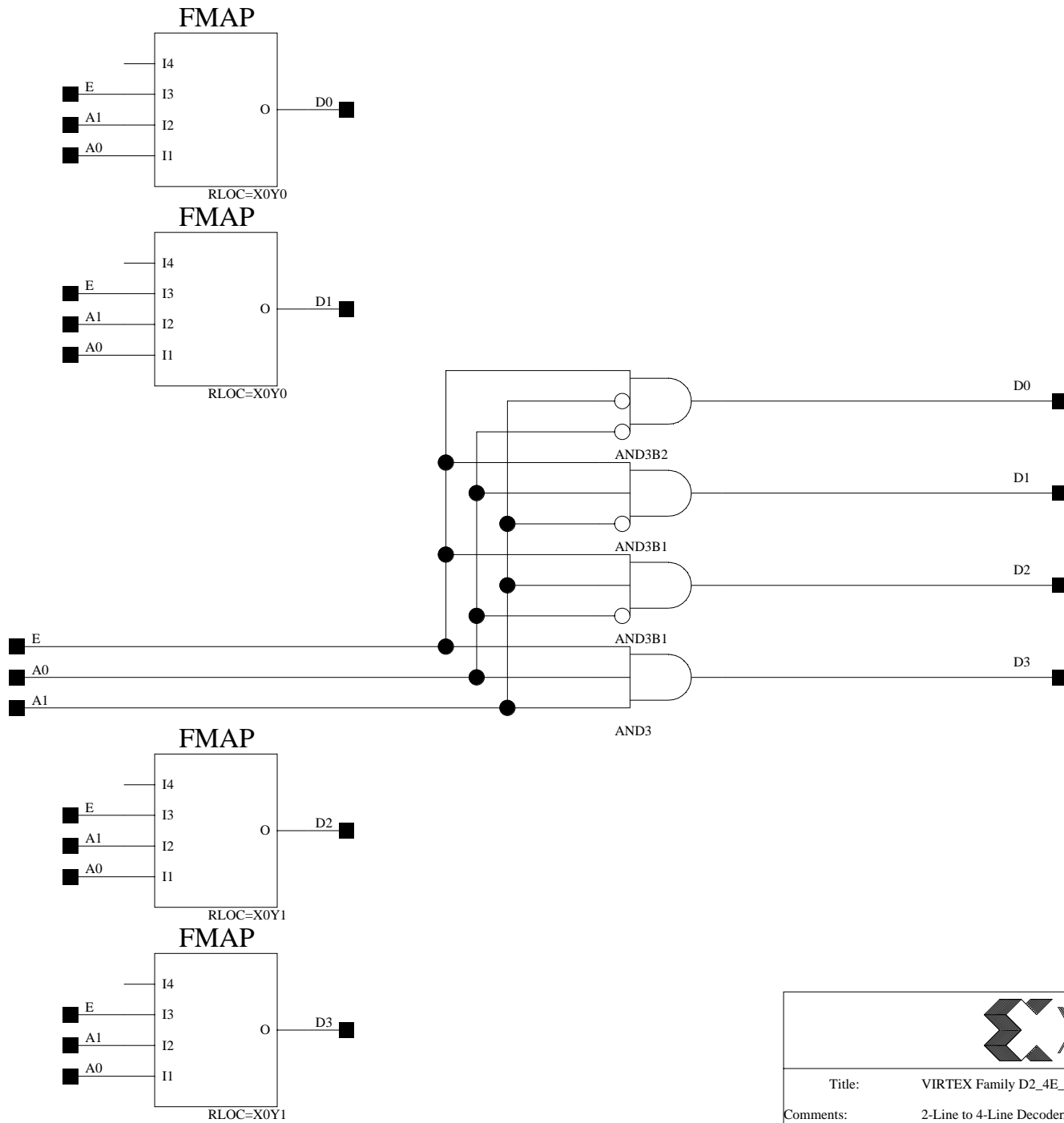

drawn by KS
 Copyright (c) 1993, Xilinx Inc.



JRG

Title:	VIRTEX Family D2_4E_rpm Macro		
Comments:	2-Line to 4-Line Decoder/ Demultiplexer w/ Enable, RPM		
Date:	11th November 2003	Ver:	1
Sheet Size:	A	Rev:	A

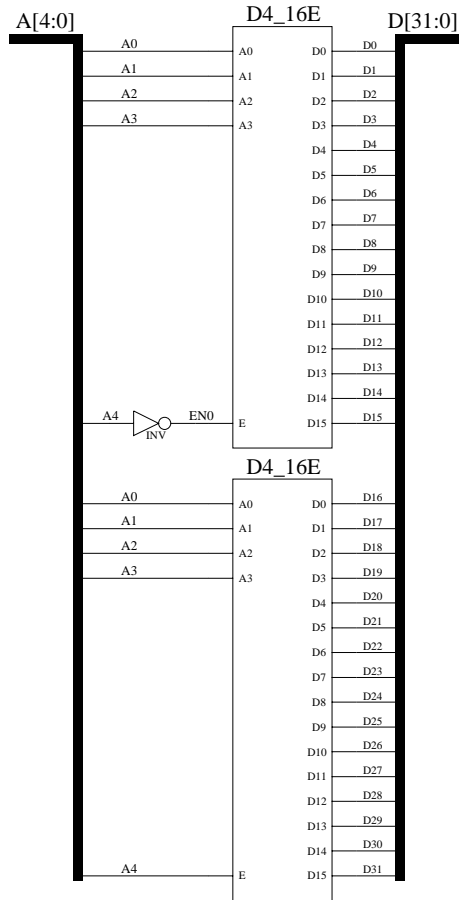

Title: VIRTEX Family Decode 32E Macro		JRG
Comments: 5-bit to 32-bit Decoder		
Date: 30th September 2003	Ver: 1	
Sheet Size: B	Rev: A	

RPM_GRID-GRID

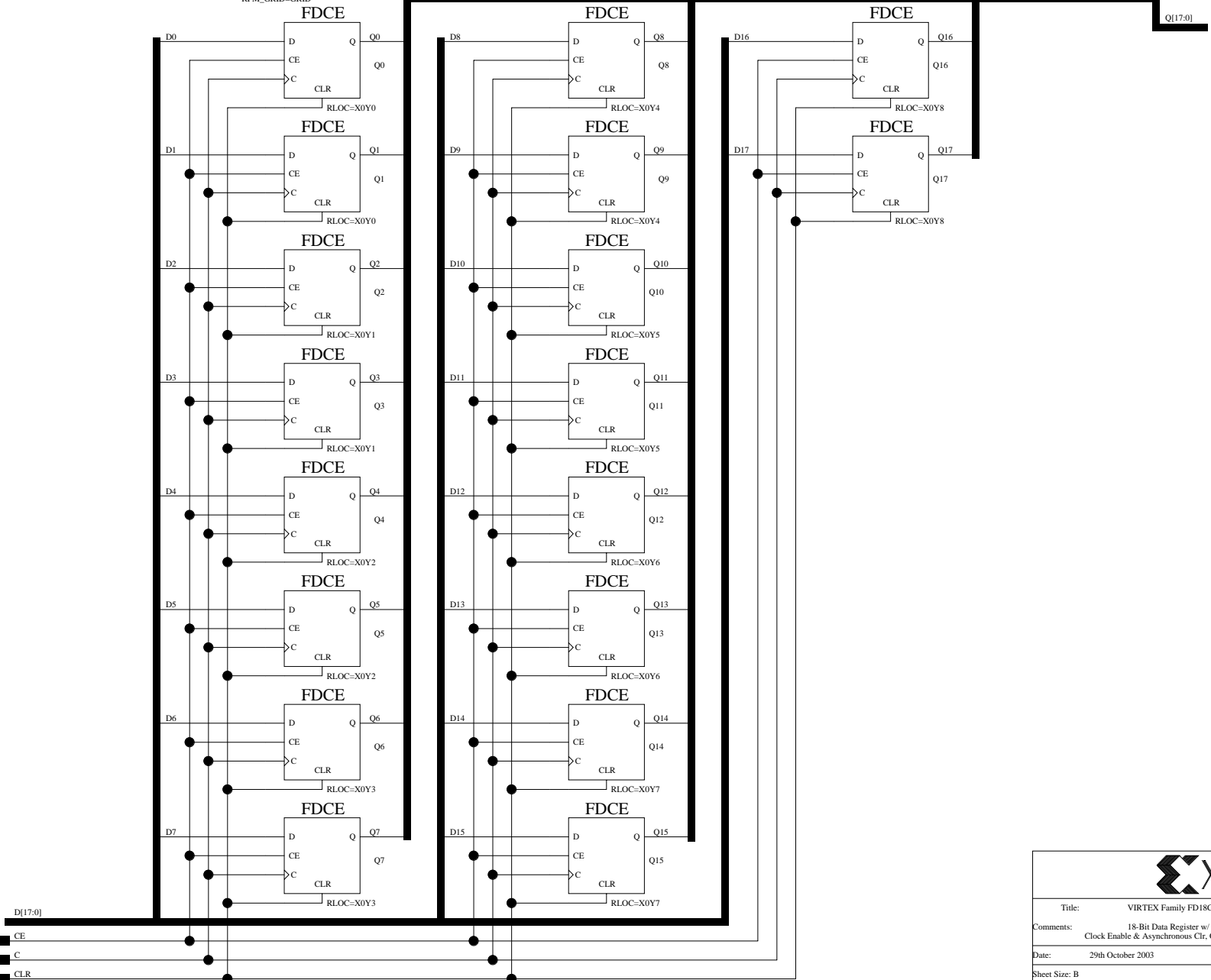

Q[17:0]



Title:	VIRTEX Family FD18CE_RPM Macro	JRG
Comments:	18-Bit Data Register w/ Clock Enable & Asynchronous Clr, GRID Coords X0Y0-X0Y8	
Date:	29th October 2003	Ver: 1
Sheet Size:	B	Rev: A

drawn by KS
Copyright (c) 1993, Xilinx Inc.

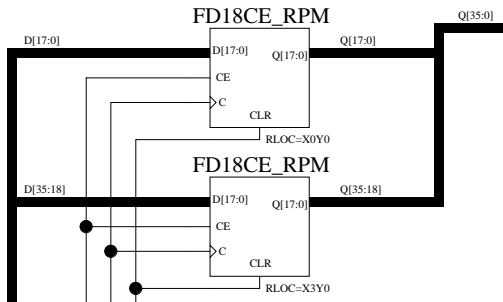

Title:	VIRTEX Family FD36CE_RPM Macro	JRG
Comments:	36-Bit Data Register w/ Clock Enable & Asynchronous Clr, GRID Coords X0Y0-X3Y8	
Date:	30th October 2003	Ver: 1
Sheet Size:	B	Rev: A

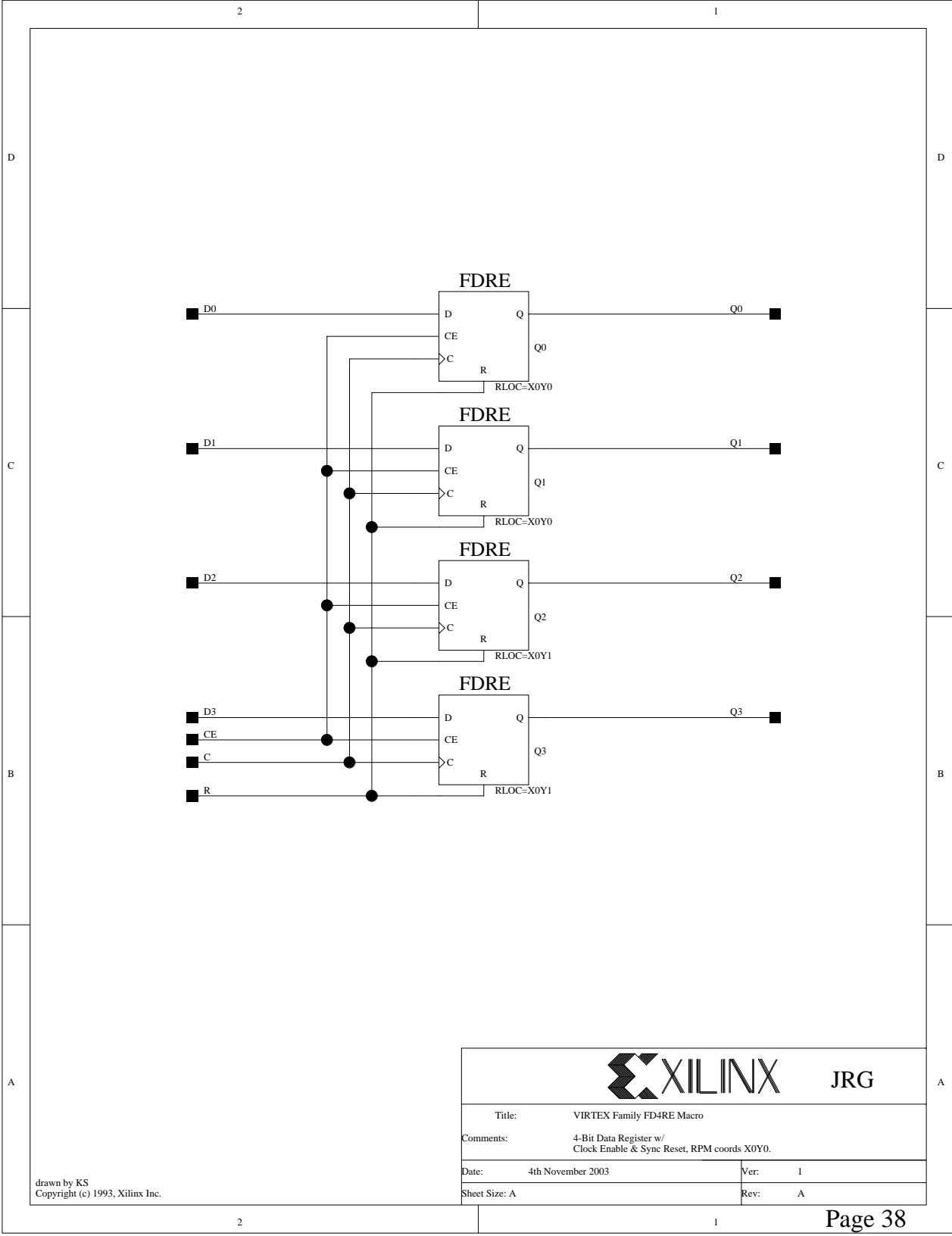

JRG

Title: VIRTEX Family FD4RE Macro

Comments: 4-Bit Data Register w/
Clock Enable & Sync Reset, RPM coords X0Y0.

Date: 4th November 2003

Ver: 1

Sheet Size: A

Rev: A

drawn by KS
Copyright (c) 1993, Xilinx Inc.

drawn by KS
Copyright (c) 1993, Xilinx Inc.

RPM_GRID=GRID

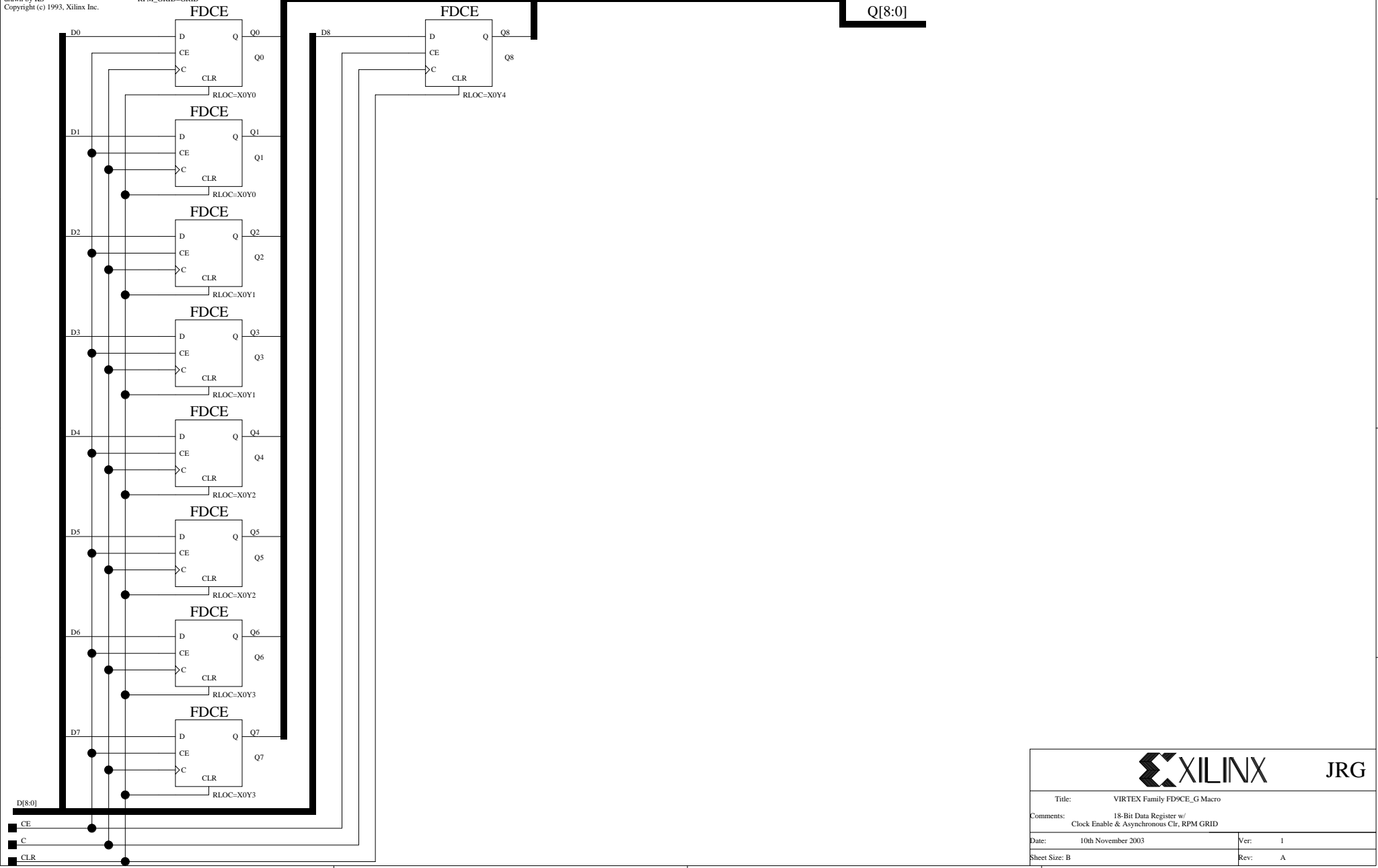

		JRG
Title: VIRTEX Family FD9CE_G Macro		
Comments: 18-Bit Data Register w/ Clock Enable & Asynchronous Clr, RPM GRID		
Date: 10th November 2003	Ver: 1	
Sheet Size: B	Rev: A	

drawn by KS
Copyright (c) 1993, Xilinx Inc.

RPM_GRID=GRID

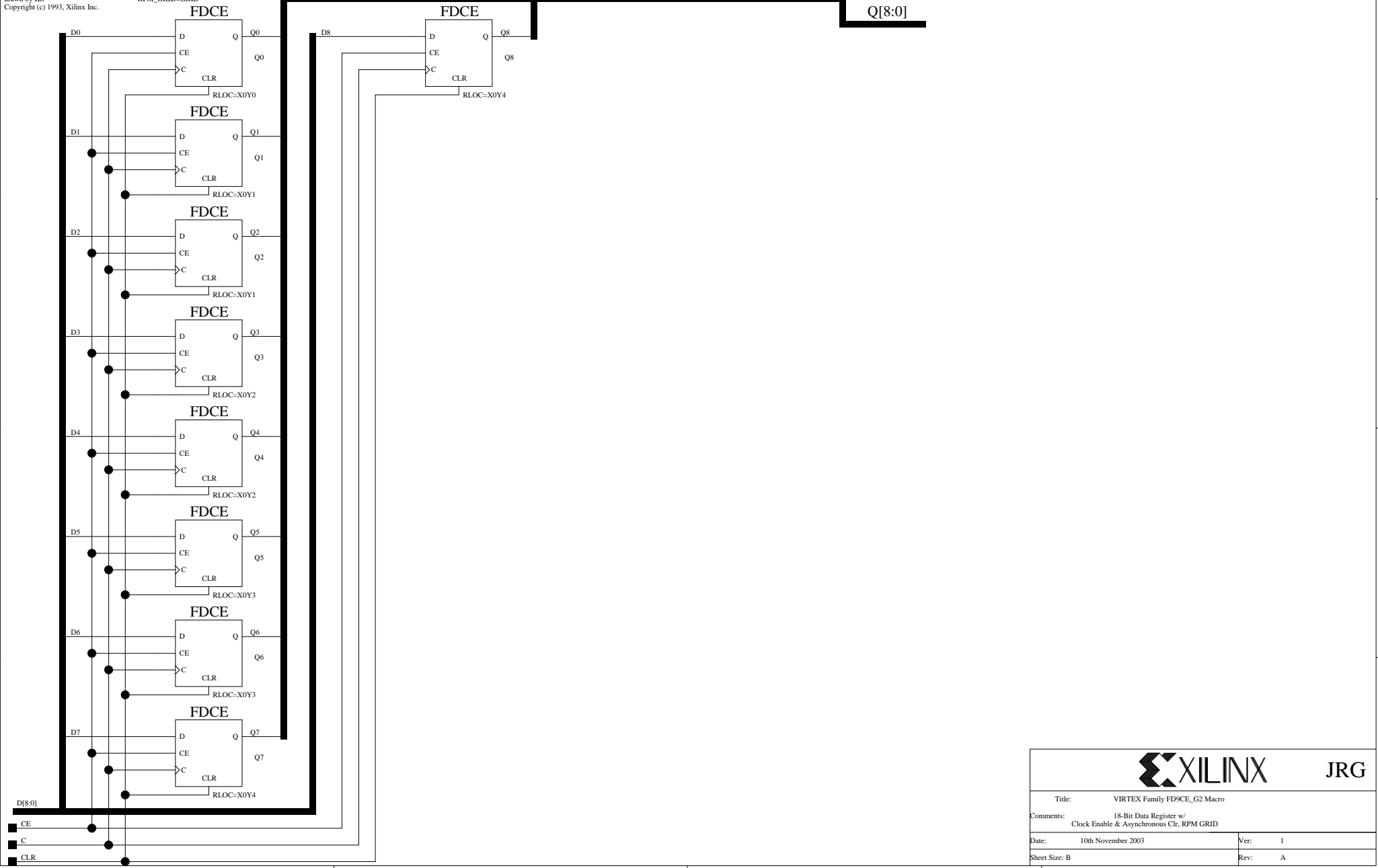

JRG

Title: VIRTEX Family FD9CE_G2 Macro	
Comments: 18-Bit Data Register w/ Clock Enable & Asynchronous Clr, RPM GRID	
Date: 10th November 2003	Ver: 1
Sheet Size: B	Rev: A

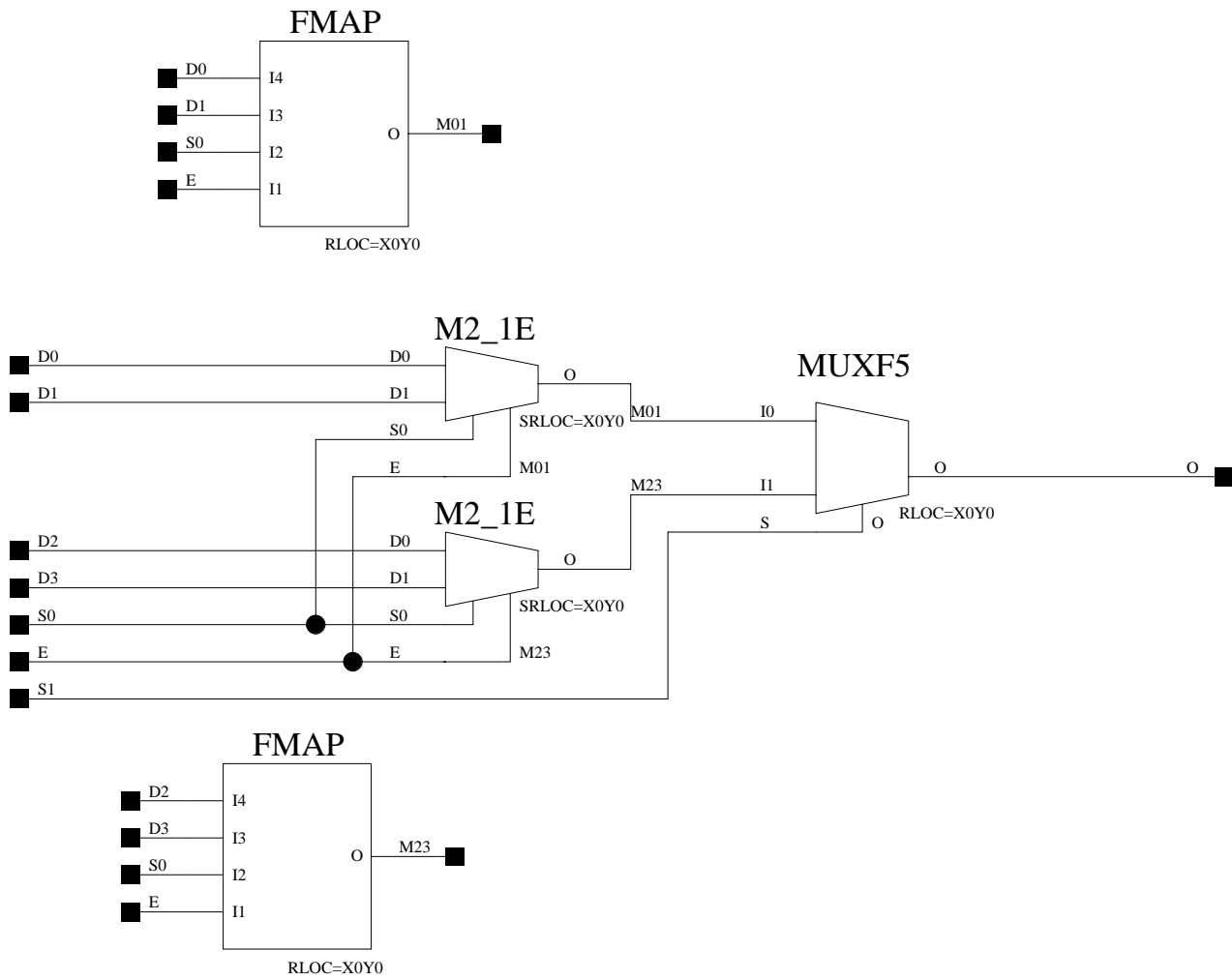

Title: VIRTEX Family M4_1E_RPM Macro	
Comments: 4-to-1 Multiplexer with Enable	
Date: 31st October 2003	Ver: 1
Sheet Size: A	Rev: B

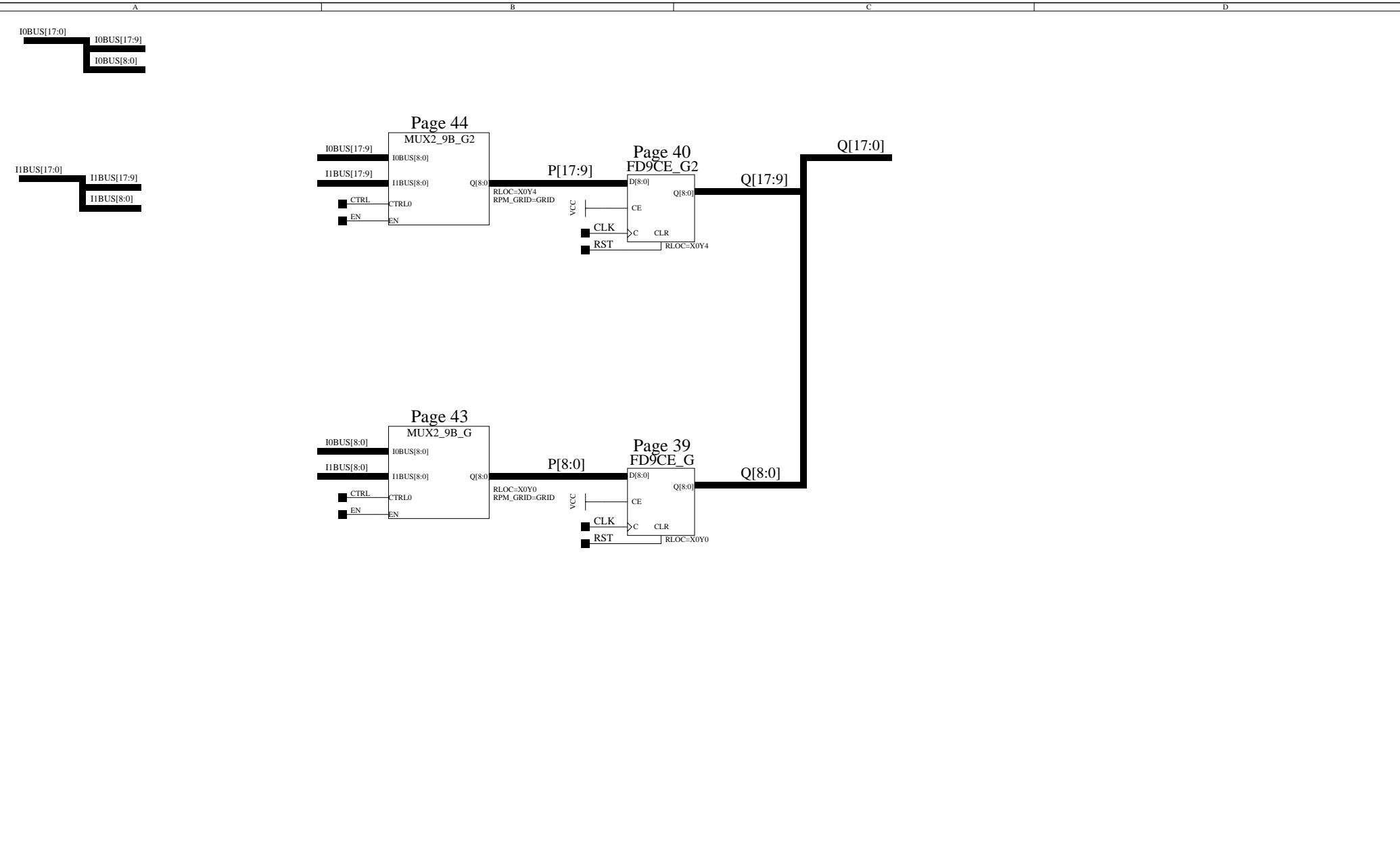

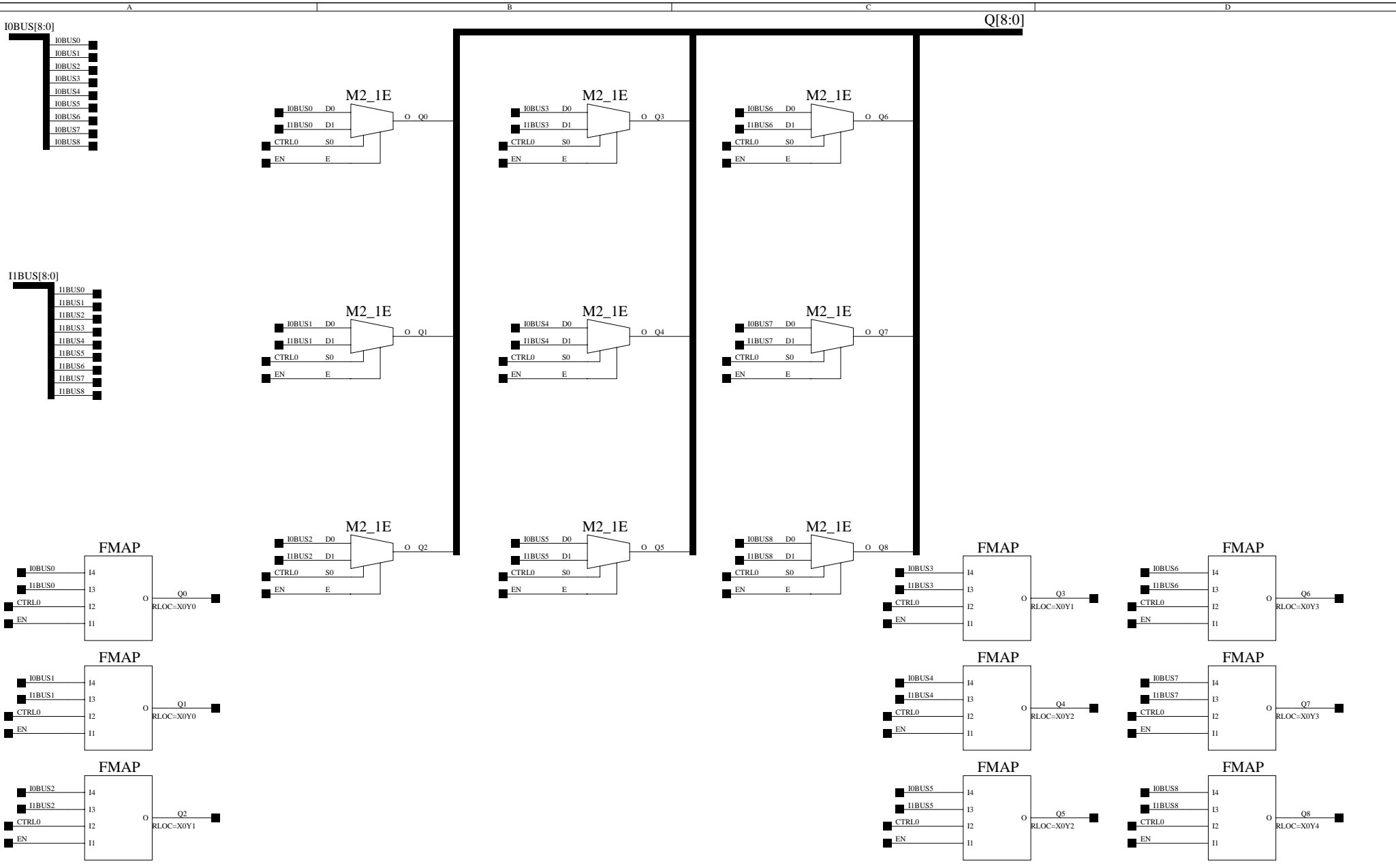

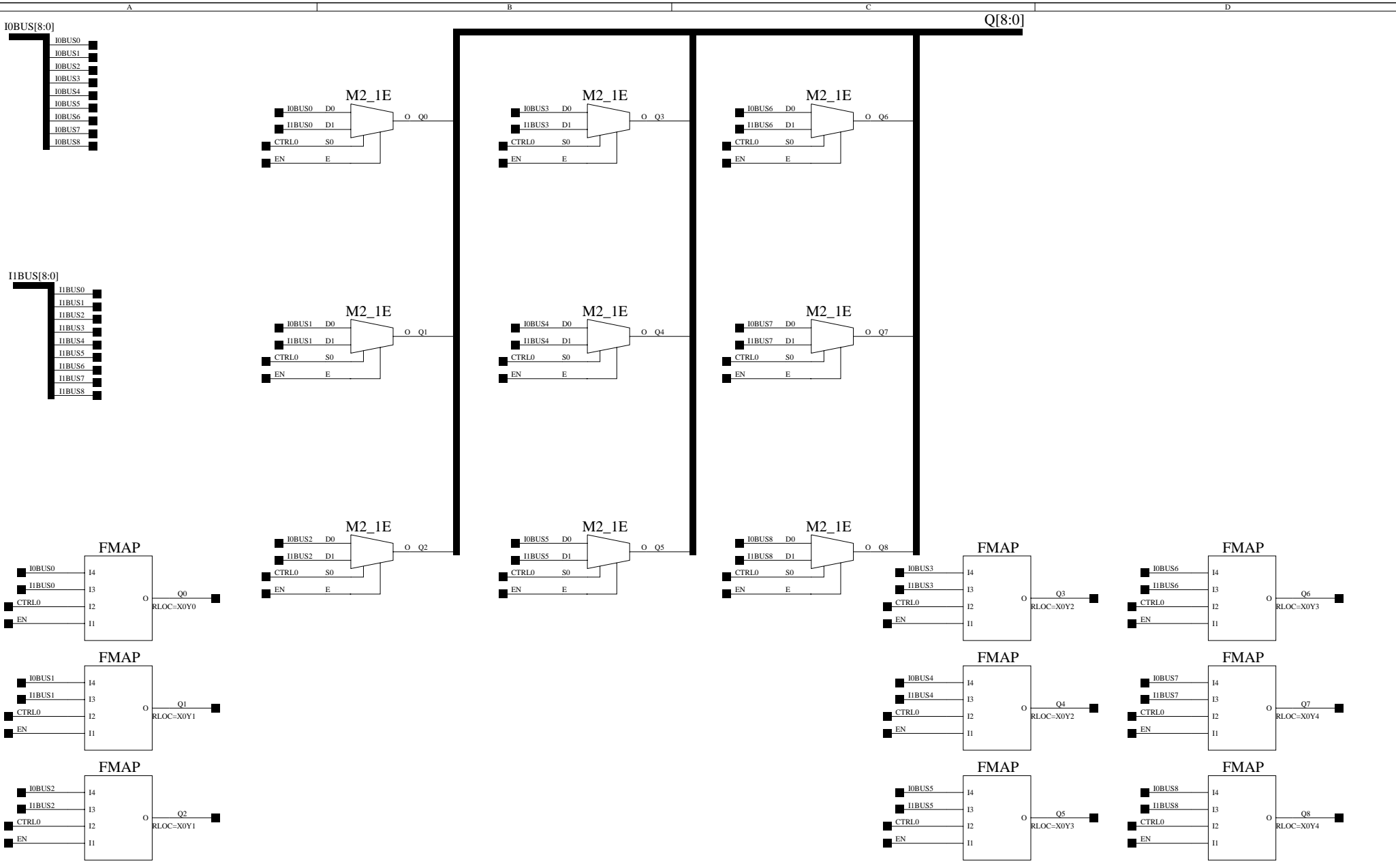

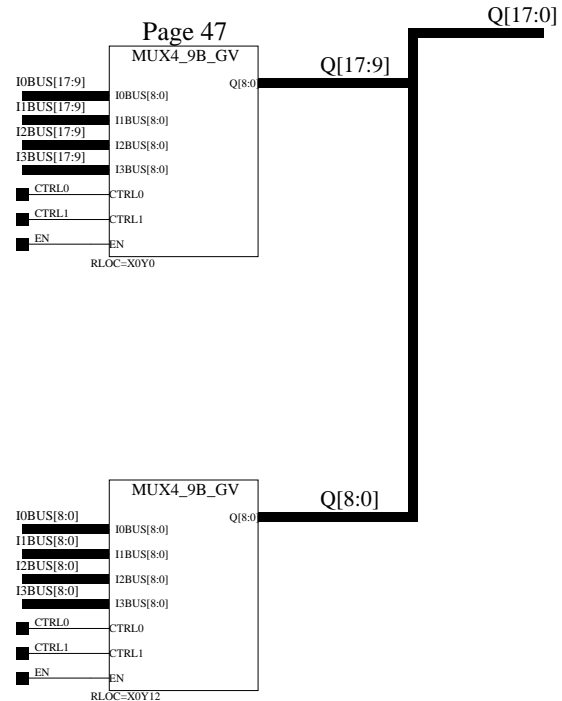
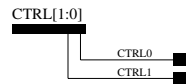
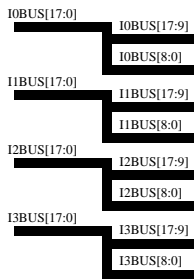

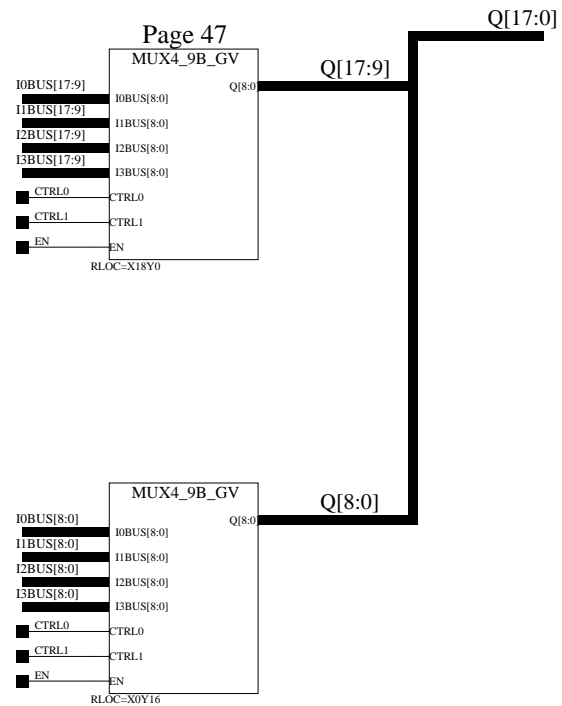
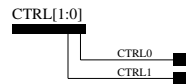
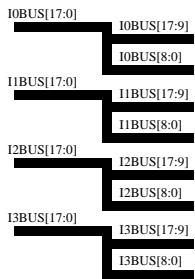

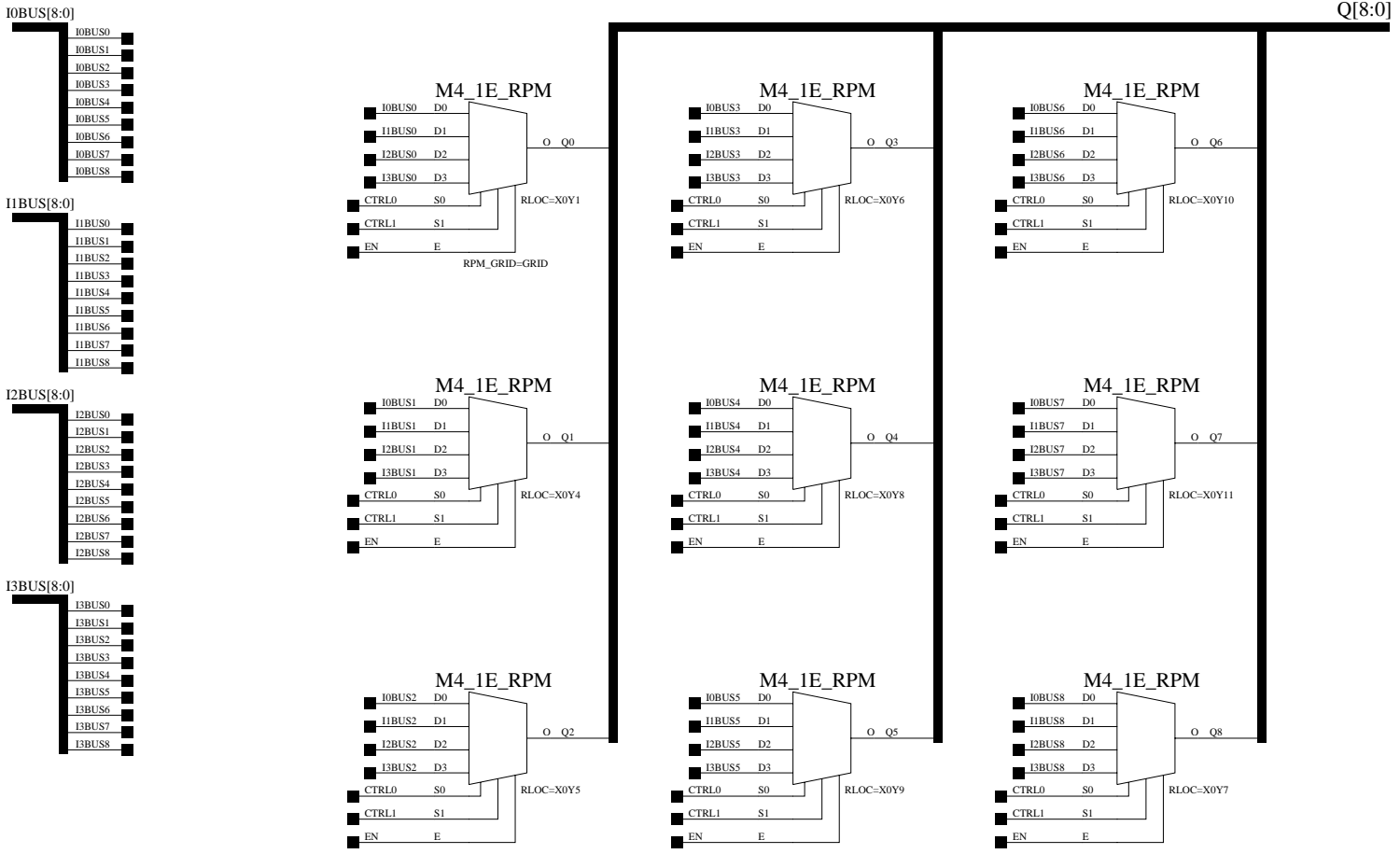

drawn by KS
Copyright (c) 1993, Xilinx Inc.

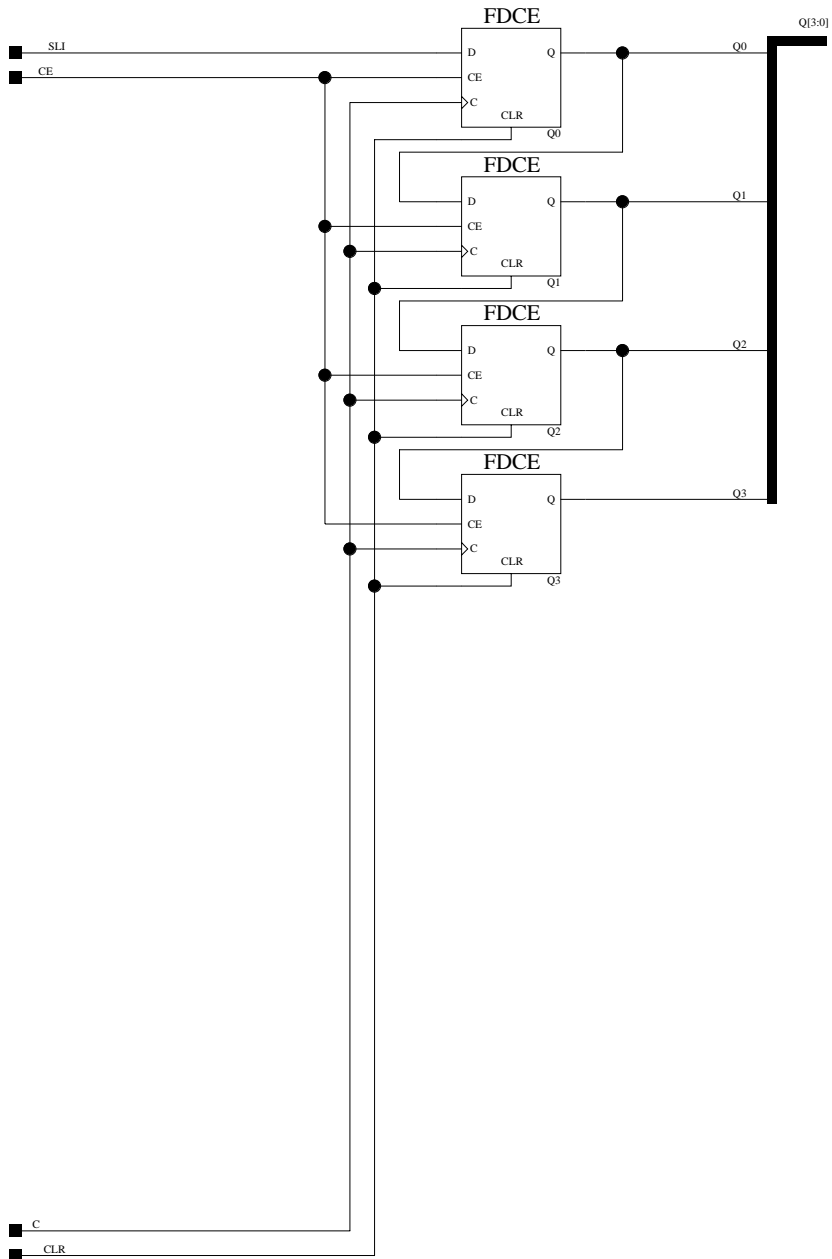

JRG

Title:	VIRTEX Family SR4CE Macro	
Comments:	4-bit Serial-In Parallel-Out Shift Register w/ Enable and Async Clr	
Date:	3rd October 2003	Ver: 1
Sheet Size: B		Rev: A

drawn by KS
Copyright (c) 1993, Xilinx Inc.

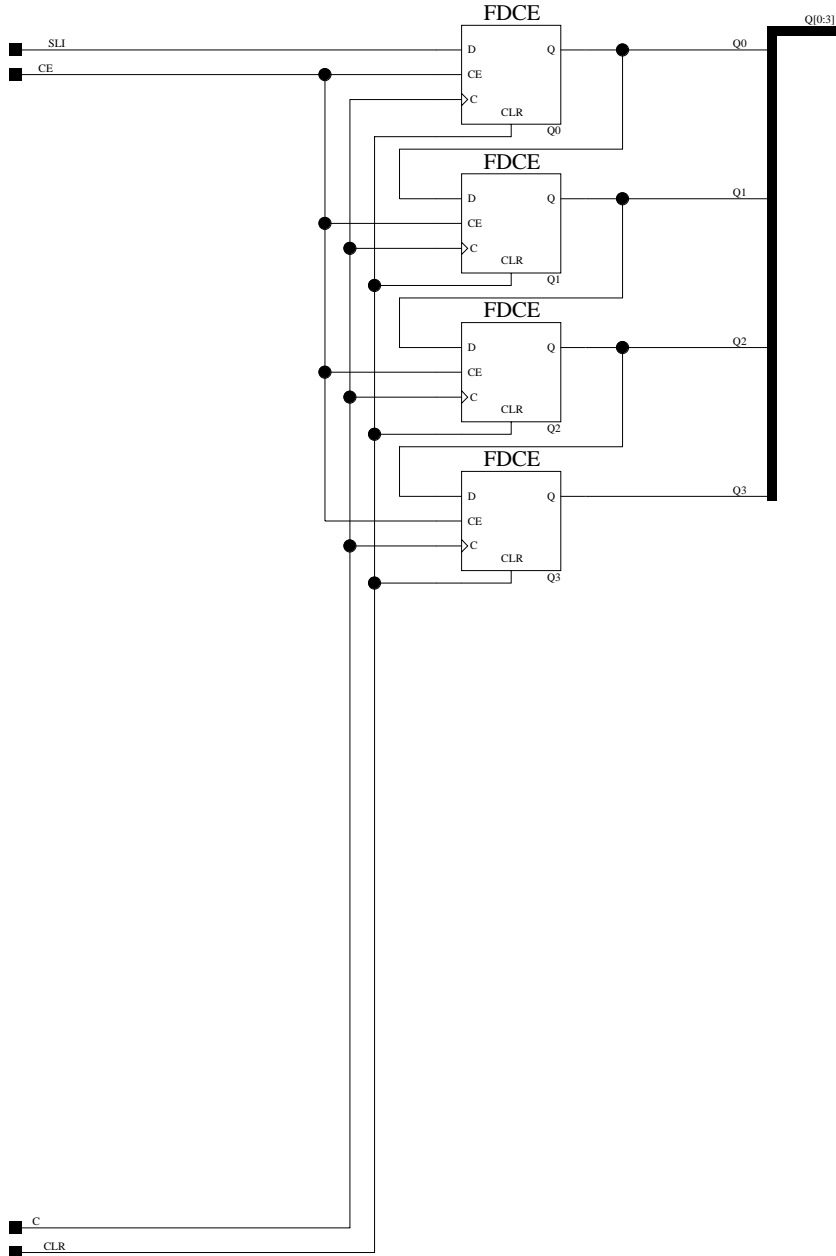

Title: VIRTEX Family SR4CE_R Macro		JRG
Comments: 4-bit Serial-In Parallel-Out, REVERSED ORDER on OUTPUT BUS! Shift Register w/ Enable and Async Clr		
Date: 3rd October 2003	Ver: 1	
Sheet Size: B	Rev: A	